

*Hurst 304*  
RADIO'S LIVEST MAGAZINE



October  
25 Cents

Canada 30c

# Radio-Craft

HUGO GERNSBACK Editor



## THE MARIMBALITE

A New Musical Instrument

See Page 204



An Ultra-Small Set Analyzer – The New "Half-Doublet" All-Wave Antenna  
A 6-Tube All-Wave Set – A Compact Tube Tester – Converting Old Sets

# And Now Supreme's own



# METERS

- Supreme Meter \$6.25
- Supreme Rectifier \$2.75
- Supreme Resistor Kit \$4.00

At last, Supreme's own meters. Designed from the daily experience in home and laboratory by a radio service organization for radio servicemen. They give the final stamp of engineering skill to Supreme 1935 instruments. Model No. 310 is a 5-inch d'Arsonval meter, specifically built for universal applications in radio testing equipment. Easy readability—the d'Arsonval movement moves the pointer over a range 26 per cent longer than usual meter scale. Fan-shaped bakelite housing moulded for semi-flush mounting makes it mountable in ordinary meter circular hole. Dimensional drawing with each meter, usable as template for drilling a panel. Each meter equipped with drawing of circuit and resistance values, thus enabling serviceman to construct AC-DC point-to-point tester.

## INCREASE TUBE SALES WITH "Neonized" LEAKAGE DETECTION! NEW SUPREME 85 TUBE TESTER

**\$39<sup>95</sup>**

Reborn in design and efficiency, the famous Supreme No. 85 Tube Tester. Portable and counter 1935 models, are the sensation of the jobbers' displays. The No. 85 has long been recognized as the most complete and accurate of all tube testers. Laboratory comparisons prove the quality tests of the Model No. 85 equal or exceed the best commercial testers. Supreme's 5" full-vision meter indicates true condition of all tubes in terms "good" or "bad." But its detection of leakage and short circuited conditions is what puts the No. 85 in a class by itself. It's really two testers in one, offering a "double check" worth as much as any tube tester alone. As many tubes require replacement because of noisy operation caused by internal leakages and intermittent shorts as for all other reasons. Model No. 85 is so far ahead in detecting these faults that it pays radio servicemen to replace present inefficient testers with this new super-tester. For example, tests show that in the ordinary tester, tubes having leakage across the cathode and heater elements, and tubes with leakage across the plate and screen elements, etc., will test "good" but won't perform in the radio. The Model No. 85 instantly detects this fault and the Neon light flashes the elements between which the leakage exists. Any owner of the No. 85 can relate experiences of increased tube sales resulting from detection impossible in the old style tube testing meters. Equip for profit with this new super-tube tester. Supreme exclusive. Neonized tube testing is added assurance that Supreme 1935 service instruments of every type forecast progress in design, are indeed "Supreme by comparison."

Ask your jobber for a demonstration. Send coupon for detailed data and complete 1935 catalog.

Supreme Instruments Corporation  
 5475 Broadway Bldg., Greenwald, Miss.  
 Please send complete detailed Catalog 1935 Supreme Models.

NAME \_\_\_\_\_  
 Address \_\_\_\_\_  
 City \_\_\_\_\_ State \_\_\_\_\_  
 Rubber Preference \_\_\_\_\_



Portable model in beautifully finished quartered oak carrying case with complete chart mounted in the cover. Counter display model in modernistic tri-toned Walnut cabinet, with tube chart conveniently stored in sliding drawer type panel in base of cabinet.

# LEARN RADIO IN 10 WEEKS!

**BY ACTUAL SHOP WORK ON REAL EQUIPMENT**

**PAY FOR YOUR TRAINING**

*-In Small Monthly Payments-*

**AFTER YOU GRADUATE**

Come to Coyne now! No need to wait till you have more cash or for "better times" to get your training in the World's most fascinating, highly-paid profession. I'll train you, here at Coyne, in a practical way so that you will be prepared to take a real job and cash in quickly! . . . AND I'LL FINANCE YOUR TRAINING! Not until two months after you have graduated will you have to start to pay me back . . . then you can take a whole year to do it in easy monthly amounts. Get the particulars of this sensational plan NOW—just mail the coupon below.



## REAL OPPORTUNITIES

### FOR THE RADIO TRAINED MAN

With Coyne training you will be qualified to accept a job as Designer, Inspector, or Tester—as Radio Salesman or in Service and Installation—as Operator or Manager of a Broadcasting Station—as Wireless Operator on a Ship or Airplane—as a Talking Picture or Sound Expert—or in any of hundreds of other fascinating, well-paid jobs.

### TALKING PICTURES—TELEVISION

Yes, Coyne training is complete! It fits you to take an important place in these new fields that offer great opportunities for trained men, and which are being developed rapidly. Be ready for your chance in Television as well as in Sound Amplification and Radio. At Coyne you are trained on real Talking Pictures and Television equipment.

### ELECTRIC REFRIGERATION—AIR-CONDITIONING

Included at NO EXTRA COST

So that you may have the kind of all-round training that increases your earning capacity, and enables you to grasp every opportunity. I am—for a limited time—including my big, new course in Electric Refrigeration and Air Conditioning. Here is a big chance for you to get practical training in a great new field at no additional cost.

### NO ADVANCE EDUCATION OR PREVIOUS EXPERIENCE NEEDED

I don't teach you by book study! Your training at

**H. C. LEWIS, President RADIO DIVISION Founded 1899**  
**COYNE ELECTRICAL SCHOOL**  
**500 S. Paulina St., Dept. 74-8H, Chicago, Ill.**

Coyne comes through actual work, under the individual guidance of expert instructors, on a great outlay of Radio, Broadcasting, Television, Talking Picture and Wireless Code equipment. Because we cut out useless theory, you can get a practical training in only 10 weeks, if you can understand simple English and are sincere in your effort.

### SPARE TIME WORK WHILE LEARNING

Employment Service After Graduation

If you need part-time work while at school to help pay expenses, I'll help you get it. And, when you enroll at Coyne, you get a lifetime scholarship and free employment service for life after graduation.

## MAIL COUPON TODAY!

### I'll Send You All the FACTS

Fill in the coupon below, and mail it to me today. As soon as I receive it, I'll send you My Big Free Book, that tells all about Coyne and contains hundreds of pictures of these great Shops, and I'll tell you all about my "Pay After Graduation Plan", and all the other features of my course.

H. C. LEWIS, President, Coyne Electrical School  
Radio Div., 500 S. Paulina St., Dept. 74-8H, Chicago

Dear Mr. Lewis: Send me your big FREE Book; details of your FREE Employment Service; and tell me all about your special offer of allowing me to pay for training on easy monthly terms after graduation.

Name.....

Address.....

City.....State.....



HUGO GERNSBACK, Editor-in-Chief

J. T. BERNSELY, Managing Editor

C. W. PALMER  
Associate Editor

R. D. WASHBURNE  
Technical Editor



## CONTENTS OF THE OCTOBER, 1934, ISSUE

VOLUME VI

Number 4

Editorial: Radio in the Bathroom.....	Hugo Gernsback	197
The Radio Month in Review.....		198
Radio Pictorial .....		200
The Latest Radio Equipment.....		202
The Marimbalite.....	Dr. Phillips Thomas	204
How Short-Waves Aid Inter-Continental Radio-telephony.....	J. T. Bernsley	206
A Power-Boosting Antenna System.....		208
12 Wave Radiophone.....		209
Tubeless P.A. System.....		209
International Radio Review.....		210
An All-Wave "1/2-Doublet" Antenna		
	Glenn H. Browning	212
Super-Short Radio Waves.....	I. Wolf	213
Uses of a Neon-Tube Condenser Analyzer		
	C. W. Palmer	214
An Inexpensive High-Gain Amplifier		
	H. V. Badinski & Jerome Newman	215
An Ultra-Small Set Analyzer.....	Rogan Shannon	216
How to Use the New Tubes.....	Wm. M. Perkins	217
A 5 Tube All-Wave Set.....	H. G. Cisin	218
Converting Old Sets.....		219
A Compact Tube Tester.....	Milton Reiner	220
A 100 W. Power Stage.....	Louis Gancher	221
An A.C. Car Generator for P.A. or Radio		
	Nat Pomeranz	221
Operating Notes .....		222
A Midget Tube and Set Tester.....		223
A 2 Tube Switch-Type S.-W. Converter		
	Herman Cosman	223
Short-Cuts in Radio.....		224
Readers' Department .....		226
<b>RADIO SERVICE DATA SHEETS:</b>		
No. 123—General Electric Model C-61 6 Tube "De Luxe" Car Radio Receiver.....		227
No. 124—Wurlitzer Lyric Model C/M-4 4 Tube Reflex Superheterodyne Chassis.....		230
RADIO-CRAFT'S Information Bureau.....		228

## IN OUR NEXT FEW ISSUES:

**THE DRAMA OF RADIO.** More frequently than we imagine radio plays an important role in the saving of a life, preventing disaster, or serving of humanity in such a manner that the recital of the facts sound stronger than fiction. Beginning our next issue, some of the dramatic incidents, in which radio played a heroic part, will be unfolded in a new, entertaining and interesting style. Every story will be a true one, some of which may have even been reported by your newspaper, but each incident so strangely interesting that we feel sure that such repetition, where it occurs, will not be monotonous to the reader.

**AN ALL-WAVE LINE FILTER.** Now that all-wave receivers are in vogue, the importance of an all-wave antenna and all-wave line filter cannot be too strenuously emphasized. Inasmuch as the subject of all-wave antennas has been thoroughly discussed in previous issues of RADIO-CRAFT, there remains for us to describe a line filter which will eliminate that possibility of noise seeping into the receiver, via the radio power socket. This type of interference is particularly noticeable on the short-waves—therefore the necessity for an efficient line filter, if satisfactory all-wave reception is to be obtained.

The filter, while seemingly elaborate, as compared to more simple devices which are seldom completely efficient, is nevertheless very easy and economical to construct. What is more, it will aid in obtaining noise-free reception on all wave bands.

**A HIGHLY EFFICIENT 4 TUBE ALL-WAVE RECEIVER.** This receiver, although it employs only 4 tubes, is equivalent in efficiency to any 6 tube receiver. An unusual arrangement of new tubes, some of which are of the "composite functioning" type, permit the attaining of such unusual efficiency. And, another outstanding feature of this set is that it can be operated from 110 A.C. (any frequency) or D.C., 32 V. supply, for rural districts, or if desired from a 6 V. storage battery only. Innovations in the design of the power supply permit this versatility.

RADIO-CRAFT is published monthly, on the fifth of the month preceding that of date; its subscription price is \$2.50 per year. (In Canada and foreign countries, \$3.00 a year to cover additional postage.) Entered at the post office at Mt. Morris, Ill., as second-class matter under the act of March 3, 1879.

Text and illustrations of this magazine are copyright and must not be reproduced without permission of the copyright owners. We are also agents for WONDER STORIES and EVERYDAY SCIENCE AND MECHANICS. Subscription to these magazines may be taken in combination with RADIO-CRAFT at reduced Club rates. Write for information.

Copyright 1934. Continental Publications, Inc.

HUGO GERNSBACK, President I. S. MANHEIMER, Secretary  
Published by Continental Publications, Inc. Publication office: 404 N. Wesley Ave., Mount Morris, Illinois. Editorial and Advertising Office: 99 Hudson Street, New York City. Chicago Advertising Office: L. F. McClure, 919 North Michigan Avenue, Chicago, Ill. Western Advertising Office: Loyd B. Chappell, 511 So. Alexandria St., Los Angeles, Calif.

London Agent:  
Hachette & Cie., 3 La Belle Sauvage, Ludgate Hill, E.C. 4  
Paris Agent: Hachette & Cie., 111 Rue Reaumur  
Australian Agent: McGills Agency  
179 Elizabeth St., Melbourne

# How a "Tip" got Tom a Good Job

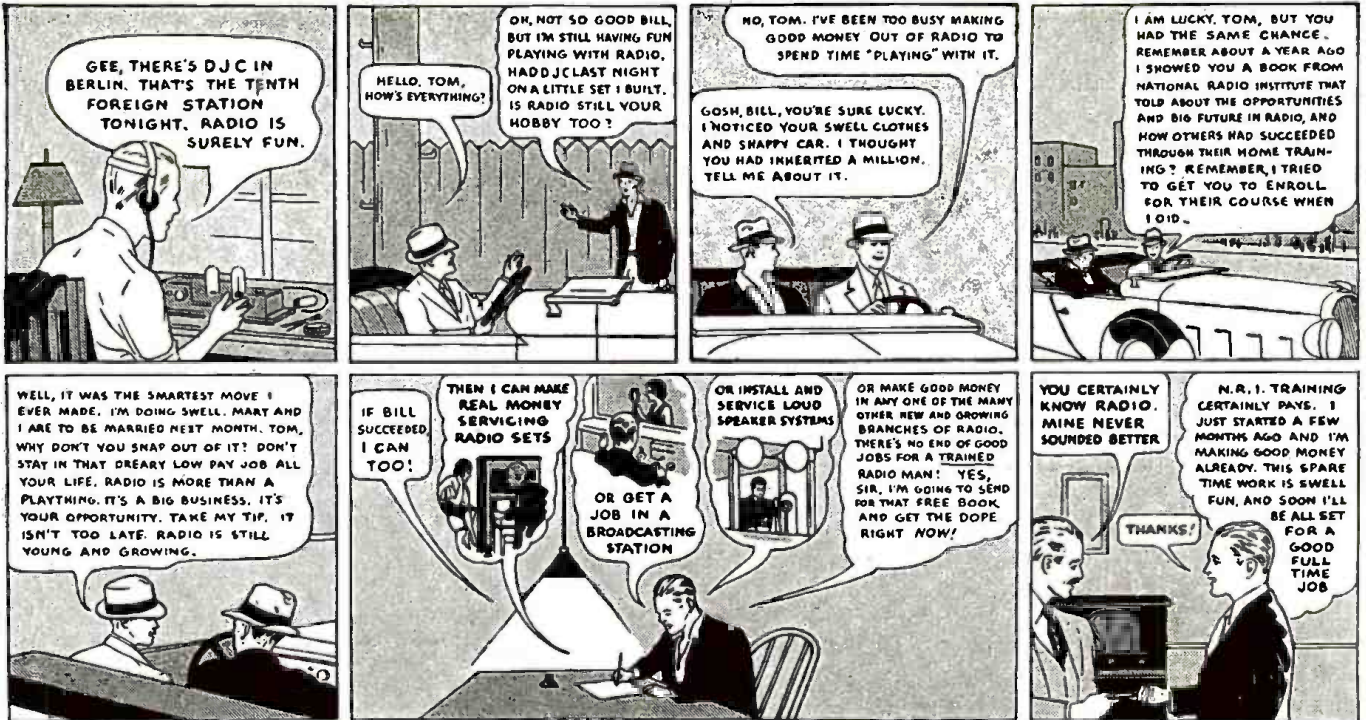

## HERE'S PROOF THAT N.R.I. MEN MAKE GOOD MONEY

### "Made \$6,000 in 2 Years"

"Soon after the depression started, I found myself without a job, but I was well protected with N. R. I. training. I swung right to full time Radio servicing and I have made over \$6,000 in a little over two years."—Wm. Spartano, Sparty Radio Service, 93 Broadway, Newark, N. J.



### "\$500 a Year in Spare Time"

"Although doing spare time Radio work only, I have averaged about \$500 a year extra in addition to my regular income. Full time Radio work would net me many times that amount."—Edw. H. Fawcett, Slough Rd., Ladner, B. C., Canada.



## FREE: Radio Servicing Tips

Let me PROVE that my Course is clear, easy to understand, and fascinating to study. Send the coupon for a free lesson, "Trouble Shooting in D.C., A.C. and Battery Sets." This interesting lesson gives 132 ways to correct common Radio troubles. I am willing to send this book to prove that you, too, can master Radio—just as thousands of other fellows have done. Many of them, without even a grammar school education, and no Radio or technical experience, have become Radio experts and now earn two or three times their former pay. Mail the coupon now.

..... I will help you start a spare time or full time **Radio service business Without Capital**

## Many Radio Experts Make \$40, \$60, \$75 a Week

The world-wide use of Radio sets has made hundreds of opportunities for good spare time or full time Radio businesses. Many of the seventeen million Radio sets are only 25% to 40% efficient. I will show you how to cash in on this condition. I will show you how to install and service all types of receiving sets in spare time. I'll show you how to make enough money while learning Radio to start your own service business. Clip the coupon. Get my free book, "Rich Rewards in Radio." Read how hundreds of N. R. I. men have made good money in spare time or full time businesses.

### Many Make \$5, \$10, \$15 a Week Extra in Spare Time While Learning

The day you enroll I send you directions for doing 28 Radio jobs common in almost every neighborhood for spare time money. I give you plans and ideas that have made \$200 to \$1,000 a year for many N. R. I. men in spare time. My Course is famous as "The Training that pays for itself."

### Get Ready Now for a Business of Your Own and for Jobs Like These

In just about 15 years Radio's growth has created over 300,000 jobs. Thousands more jobs will be opened by new Radio developments. Broadcasting stations use engineers, operators, station managers and pay up to \$7,000 a year. Manufacturers employ testers, inspectors, foremen, engineers, servicemen, buyers, for jobs paying up to \$7,500 a year. Dealers and jobbers employ servicemen, salesmen, buyers, managers, and pay up to \$100 a week. My Free Book tells about these and other opportunities.

### Television, Short Wave, Loud Speaker Systems Included

There is opportunity for you in Radio. Its future is certain. Television, short wave, loud speaker systems, ship Radio, police Radio, automobile Radio, aviation Radio—in every branch, developments and improvements are taking place. Here is a real future for thousands of men who really know Radio—men with N. R. I. training. Get the training that opens the door to good pay and success in this growing industry.

### Find Out What Radio Offers You

I am so sure N. R. I. can train you satisfactorily that I agree in writing to refund every penny of your tuition if you are not satisfied with my Lesson and Instruction Service upon completion. Get my 64-page book of facts. It's free to any ambitious fellow over 15 years of age. It tells you about Radio's opportunities; about my Course; what others are doing and making. Find out what Radio offers you. No obligation. ACT NOW! Mail coupon in an envelope, or paste it on a 1c postcard.

**J. E. SMITH, President**  
**Nat'l Radio Institute, Dept., 4KX**  
**Washington, D. C.**



Dear Mr. Smith, Without obligation, send me the Service Manual and your free book about spare time and full time Radio opportunities and how I can train for them at home in spare time.

NAME..... ADDRESS..... CITY..... STATE.....

**J. E. SMITH, President**  
**National Radio Institute, Department 4KX**  
**Washington, D. C.**

AGB.

**MAIL THIS for FREE 64 page book**

The 1935 Manual—

**1,000** PAGES

but only an 1 1/4" thick\*



9 x 12  
Inches

1 1/4"  
Thick

NO other radio book in history is comparable to the 1935 OFFICIAL RADIO SERVICE MANUAL. In contents, in style of printing, in grade of paper, in illustrations, there has never been published such a comprehensive volume.

The 1935 Manual contains over a thousand pages—yet it will be only 1 1/4 inches thick because it will be printed on a special Bible stock which is an exceptionally good stock, yet one of the thinnest and most durable papers. This new Manual will be voted as the most authentic and elaborate service guide ever voted as the most authentic and elaborate service guides ever used in the radio industry. Service Men and dealers who use this 1935 Manual will be astonished by finding in it such a wealth of profitable service information which has never been previously made available.

**Contents Reveals Important Chapters in the Contents of the 1935 Manual**

- Over 1,000 pages full of diagrams and essential information of manufactured receivers—only data of real use in servicing is included. This new Manual is really portable since it will be extremely thin and light as well.
- Volume V continues where the preceding manual left off—none of the circuits published have ever appeared in any previous volumes of the OFFICIAL RADIO SERVICE MANUALS.
- Many circuits of extremely old sets not previously available are included.
- Service Men know every radio set has certain weak points which are really the cause of trouble. Wherever the information could be obtained, these weaknesses with their cures are printed right with the circuits. This is an entirely new and valuable addition to the Manual.
- All the latest receivers are included—all-wave sets, short-wave sets, auto-radio sets, midget and cigar-box sets, etc., as well as P. A. amplifiers and equipment, and commercial testing and servicing instruments.
- The cumulative index is even more complete than before; including cross-reference to sets sold under different names and type numbers identical with circuits printed in this or previous volumes.
- Volume V includes resistance data; socket layouts; I. F. data; voltage data; color codes of wiring, cables, etc.; and the purpose of each tube in the set is clearly indicated on the diagram.
- Tube data on latest tubes and all previous types will be included to facilitate servicing.
- Free question and answer service—as included in our last three manuals.

**Three Big, Special Offers—See Coupon**

In the coupon below will be found the same three special offers as they appeared in our recent circular. Here is the last opportunity for you to save a few dollars by taking advantage of our PRE-PUBLICATION OFFER—BUT YOU MUST ORDER NOW before the book is published—about October 15th. Check the offer in the coupon most convenient to you and mail it to the publishers today. DON'T DELAY!

**OVER 1,000 PAGES**

Over 3,000 Illustrations. Flexible, loose-leaf covers  
Size 9 x 12 inches - yet only 1 1/4 inches thick

**GERNSBACK PUBLICATIONS, Inc.**  
99 Hudson Street New York, N. Y.

GERNSBACK PUBLICATIONS, INC. IC-1034  
99 HUDSON ST., NEW YORK, N. Y.

Gentlemen—Herewith is my remittance for \$..... to cover the pre-publication price for one copy of the 1935 OFFICIAL RADIO SERVICE MANUAL, the regular price of which Manual is \$7.00. I have marked in the square below the offer chosen. It is distinctly understood by me that, should this Manual be offered for sale within a year by a reputable mail-order house or dealer for less than this amount, you will return the difference to me.

I understand that the new Manual is to be published about October 15th. On all three offers the postage is prepaid the publishers. This is an additional saving for you.

**OFFER NO. 1**  
 I enclose \$5.00 in full (during the month of September, 1934), for the total price of the 1935 Manual. This saves me \$2.00.

**OFFER NO. 2**  
 I enclose \$3.00 now (during the month of September, 1934). I will pay the postman \$3.00 when the 1935 Manual is delivered. This saves me \$1.00.

**OFFER NO. 3**  
 I enclose \$6.50 now (during the month of September, 1934), and I am to get FREE a one-year subscription to RADIO-CRAFT Magazine. This saves me \$3.00.

NAME .....

ADDRESS .....

CITY ..... STATE .....

(Remittance should be made in U. S. or International Money Order; we also accept personal checks. If you remit in cash, or should you send new and unused U. S. Postage stamps, which we also accept, be sure to register your letter.)

CLIP  
THIS  
COUPON  
AND  
MAIL  
TODAY!

**SET SERVICING**



Authentic service information found in the 1935 Manual of a thousand pages covers all types of radio receivers in use today. The material will be extremely valuable to every Dealer and Service Man. On the diagrams of the receivers, wherever possible, appear voltage readings of tubes, socket connections, intermediate frequencies, transformer data, alignment details, common causes of trouble and other valuable service notes.

**PUBLIC ADDRESS**

The many pages on new, outstanding developments in Public Address Installation and Service will be found helpful to Service Men and P. A. specialists. Such prominent features as class A and B amplifiers—single and dual channel systems—attenuators, and mixers—super-power stages—Pre-amplifiers and other commercial devices available for public address and call work, will be found in this complete reference volume.

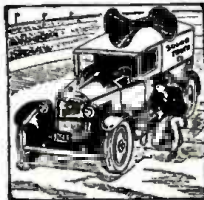

**ALL-WAVE RECEIVERS**

Information relative to short waves have found their way into the 1935 by popular demand. The numerous all-wave receivers now being sold by practically all the large radio set manufacturers are included. For these sets, wherever possible, complete aligning details for all wave bands are included in addition to the service material listed for other sets.

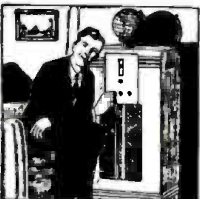

**AUTO-RADIO RECEIVERS**

No service manual could be complete without a section devoted to auto-radio. All available service information on new auto-radio sets has been included. From this section alone Service Men could derive sufficient knowledge to venture in a specialty field—that of servicing only auto-radios. It is one of the biggest opportunities in radio today.





"Takes the Resistance out of Radio"

Editorial Offices: 99 Hudson St., New York, N. Y.

HUGO GERNSBACK, Editor

Vol. VI., No. 4, October, 1934

# RADIO IN THE BATHROOM

An Editorial by HUGO GERNSBACK

**B**ELIEVE it or not, there is in this country alone, a market for some 18 million radio sets, a market which has apparently never been considered.

There are some 30,000,000 homes in the United States. It is estimated through various sources that these homes have not less than 18 million bathrooms; and in all seriousness I ask the question, why should there not be a radio in every bathroom in the United States?

Most men and women spend a considerable amount of time in the bathroom, in attention to their cleanliness and personal appearance; and more time is thus spent in bathrooms in the United States than perhaps in any other country on the globe. Even the man who shaves most rapidly in the morning still spends fifteen to twenty minutes in the bathroom; during which time his mind is receptive.

Here then, is a huge market for radio sets which has probably never been considered by most of the radio manufacturers—because if they had considered it they probably would have made the sets by this time. We have all sorts of inane designs of radio sets in the United States today. Just to mention a few: Beer Keg and Beer Bottle Radios; Book Radios; Radio in a Vase; Radios with Bar and Liquor Attachments; Radios for the Desk Drawer; Lamp Radios; Boudoir Radios; Children's Radios; "Mickey Mouse" Radios. Why go on with the list? Anyone can complete it, by adding several dozen more of the same variety.

But why no bathroom radio? The reason may be simple; if any manufacturer has considered it, he probably shied away from it, for the reason that the moisture—the steam in the bathroom—would no doubt put an ordinary radio set out of commission in short order.

When radio manufacturers first thought of automobile receivers—which were laughed at in Europe as another insane American wrinkle—the first of these sets were not satisfactory, because too many technical problems had to be overcome. There had to be evolved ignition silencers. Then, there was the question of vibration, which shook the ordinary radio set to pieces in no time. An entirely new technique had to be evolved. The auto set had to be made much smaller, more compact, more sturdy; in other words, it had to fit a certain condition, and the radio industry soon learned how to meet the condition.

Now then, waterproofing a radio set for bathroom purposes is not such a difficult proposition as it sounds. Many years ago, the electrical industry was faced with a parallel condition when telephones had to be built for mines, ships, and outdoor work, such as police posts, etc.

In waterproofing the radio set, similar conditions prevail, and the remedies are rather simple. What probably has bothered the radio manufacturers, who may have thought of the bathroom idea, is the fact that they have been accustomed to keep their radio sets open in the back, as well as in the front. This was, of course, done with the

idea to get better (?) acoustics—and also to accumulate more and better dust—a condition of which I have spoken many times. In the front, where the loudspeaker faces the owner, we are accustomed to a piece of gaudy cloth, which lets the sound through. In the back we have nothing. Now then, the speaker front and the back of the cabinet can readily be closed hermetically by many substances which would let the sounds through, but keep water and moisture out. Such substances as parchment (as is used for drums), cellophane, varnished cloths or silks and other thin materials can seal up a small radio set perfectly, yet not interfere with the sound at all.

Not so long ago I was curious as to what effect enclosing a set hermetically would have on its sound; I took a small cigarbox radio and closed it up, by applying a parchmentlike skin, which I took from a toy drum bought in a department store. The skin was tightly stretched (by means of a special frame, which I constructed for both front and back) and, believe it or not, the set sounds just as good now as it did before, and is actually doing valiant service in my bathroom. It is not at all affected by moisture and steam from the hot bath. To be sure, the set now is a makeshift; but if it were manufactured in quantity, with a little additional research and the proper engineering behind it, there is no question but such a set would last for years without any humidity getting into the inside. Of course, the dial part must be considered too, as well as the knobs; and here oiled felt, in which the shafts turn, can be used as a repellent of moisture so that no water or moisture will get into the set by way of the bearings. The dial opening presents no difficulties, as this can be hermetically sealed; in fact, there are now some such sealed dials on the market.

Needless to say, the casing must be of bakelite or some other molded material, not affected by moisture or water. The connecting cord, which goes to the electric light plug is easily waterproofed too, by means of a soft rubber bushing; so is the aerial, no ground being used with modern sets of this kind.

The moulded bakelite case can come in any color to suit the gaudy bathrooms, from pink to purple, black, or green, so much in vogue today. The reason for this is that the lady of the house will have something to say about it and, if her bathroom is done in orchid, she naturally will wish to have an orchid radio set to match.

There remains one more point, and that is, a set of this type for bathroom purposes cannot be placed on a table or shelf, because in the bathroom there is usually no place to stand it. *It must be hung up* and, for that purpose, lugs are molded right into the case, so that two screws or nails will fasten the set upon the wall, where it belongs.

I charge the radio industry nothing for the idea, and hope we will soon have with us our individual bathroom radio sets.

# THE RADIO MONTH



Major Armstrong succeeded in gaining "regeneration" rehearing.

## DEFOREST SETBACK IN FEEDBACK DECISION

**A** FEW months ago we reported (RADIO-CRAFT, August issue) to readers of this column what was believed to be the final decision in the long series of litigation between DeForest and Major Armstrong as to who was the original inventor (priority) of regeneration. Incidentally, the Major is now "Professor" at Columbia University, by honorary appointment. Our reason for believing that the decision was final was due to the fact that it was handed down by Justice Cardozo of the U. S. Supreme Court, from which there is no appeal. But last month, a stay was granted on this decision, by Justice Cardozo, following a petition for rehearing by the Radio Engineering Labs.

It is interesting to note that an eminent authority on the subject, Professor Michael Pupin, in an extensive statement published in the *New York Times*, made the following summary:—"Having scrutinized carefully the scientific aspects of this case I cannot help coming to the conclusion that the Supreme Court was misled to a faulty understanding of the scientific principles underlying the results of Armstrong's and DeForest's experiments."

It is also interesting to note that when Armstrong, feeling that the medal given to him in 1917 for his work in this field was no longer rightfully his, offered to return it, and received the following reply from the board of directors:

"By the unanimous opinion of the Board of Directors of the Institute of Radio Engineers, you are informed first, that it is their belief that the Medal of Honor of the Institute was

awarded to you by the Board in 1917 with a citation of substantially the following import: That the Medal of Honor be awarded to Edwin Howard Armstrong for his engineering and scientific achievements in relation to regeneration and the generation of oscillations by vacuum tubes.

"Second: That the present Board of Directors with full consideration of the great value and outstanding quality of the original scientific work of yourself and of the present esteem and repute in which you are held by the membership of the Institute and themselves, hereby strongly reaffirms the original award and similarly reaffirms the sense of what it believes to have been the original citation."

## RADIO'S VOICE OF SAFETY

**M**OTORISTS and pedestrians in at least two large cities in the United States have to be right "on their toes" since police cars in these cities began to use "the voice of safety." In case you haven't heard of it, the voice of safety is a police car equipped with an efficient public address system and a loudspeaker. Since these cars turned up early last month, traffic law breakers in Washington and Cincinnati have been receiving the surprise of their lives.

For instance:—

A young lady tripped gaily across a heavy traffic intersection—from nowhere it seemed a voice bellowed in tones that could be heard at least a few blocks away—"Will the young lady please wait until the traffic light turns green?" She gaped in wonder. Other pedestrians gaped at her and some even

laughed, but she waited.

Again, a wily truck driver in a hurry to deliver those precious parcels sneaked past a red traffic signal. Again the voice of thunder burst forth and the surprised driver almost left his seat.

And so it went; pedestrians and motorists alike had no idea who would be spotted next and publicly cautioned. From the experience gained during the short time in which these cars have been used it seems that they can do wonders in eliminating jay walkers and reckless drivers.

## CONNECTICUT BANS RADIO IN BEER PLACES

**B**ECAUSE of a ruling by its Liquor Control Commission, last month, banning radio music in beer-dispensing places, Connecticut finds itself in an unusual situation.

Immediately after the ruling, proprietors of places selling beer desired to know what to do with their radio sets. Suppose for example a patron turned on the radio receiver and strains of music burst forth; could they be convicted for it?

Noting the confusion surrounding the edict, the Liquor Control Commission ruled that radio sets do not have to be removed from taverns, but they cannot be used to furnish music. The law is specific in barring entertainment such as music, either instrumental, vocal, or dancing, and it applies to any form of radio entertainment, even saxophones and singers. Radio sets in beer places can be used for baseball games or church sermons only and advertising blah.



Amplifier equipped "safety cars" in Cinn. and Washington, enforce laws.





# IN REVIEW

Radio is now such a vast and diversified art it becomes necessary to make a general survey of important monthly developments. RADIO-CRAFT analyzes these developments and presents a review of those items which interest all.

Harassed tavern keepers do not dare look far into the future. For example, how are they going to get around the mixture of touchdowns and college songs during the football season?

## RADIO—BY DUN AND BRADSTREET

ONCE before in these columns RADIO-CRAFT presented some interesting facts on the radio industry which were published by Dun & Bradstreet in one of their timely reports. Here is what they have to say in their latest bulletin:

"Interest in radios now has reached the highest pitch in several years, and some retailers describe current demand as measuring up to that when satisfactory sets were first so widely distributed back in 1924. Instead of the usual summer lull, the trend of sales continues steadily upward, although at a slower rate than during the first six months of the year. For, wholesale and retail volume during that period rose 50 to 75 per cent above the level reached during the comparative months of 1933, and with some of the large distributors the increase ran as high as 100 to 150 per cent for several of the nationally known sets. This substantial gain is not attributable to the stimulus of low prices, as these have held steady, but almost entirely to the widening popularity of the radio, aided by the constant improvement in the entertainment provided by broadcasting companies, the achievement of manufacturers in bringing the short-wave sets within the reach of the average buyer, and the possibility of enjoying satisfactory programs through-

out the entire twenty-four hours of the day.

"Based on the advanced inquiries for new merchandise, volume during the second six months of the current year will run ahead of the comparative figures for 1933, by 25 to 40 per cent, despite the smaller returns from the drought-stricken areas, as retailers in all parts of the country are expecting demand to swing abruptly upward, as soon as the new models will have been displayed. This will bring sales for 1934 to a conservatively-estimated total of 4,550,000 sets, as compared with the record of the peak year, of 1929, when 4,438,000 sets were sold, with a retail value of \$592,068,000, less tubes. Sales of automobile radio sets alone are expected to run to 750,000 units."

## MARCONI'S NEW INVENTION

WITH a triumphant smile, Marquis Guglielmo Marconi, standing on the bridge whose windows were covered with thick canvas, making a view to the outside impossible, piloted his yacht, *Electra* into Sesini Levante Harbor, (Italy), one day last month guided only by his latest invention "the Radio Lighthouse."

Even as his development of radio communication saved thousands of lives through timely distress calls, the radio lighthouse should save hundreds of ships from collision when entering port through fog and blinding rain. Marconi calls this his "greatest" invention.

It consists of an ultra-short-wave transmitting station situated on a high promontory about 300 ft. above the sea at the entrance to Sesini Levante Har-

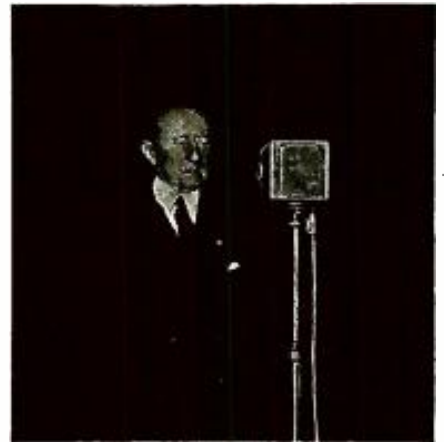

Marquis Guglielmo Marconi invents radio device to prevent "Nantucket" disasters.

bor. In addition, there are two "radio lighthouses" which consist of small ultra-short-wave transmitters mounted in large buoys floating at the entrance to the harbor, a little more than 300 ft. apart.

On the yacht there is a receiving set, equipped with two indicators, a visual one which consists of a meter-like device with a needle which moves to left or right depending on the location of the ship. An audible indicator in the form of a loudspeaker also tells when the ship is "off course."

Signals from the main transmitter are relayed by the radio lighthouses and are picked up on the ship. As long as the ship remains in the center of the course set by the two directional buoy transmitters the needle on the dial remains at the center of its scale. If it deviates to one side, the ship has veered from its present course. The ship entered the harbor safely although Marconi and the ship's captain guided it blindly without any view of the shore line or the entrance to the harbor. Marconi said that within a few years practically every harbor in the world would be equipped with one of these radio beacons.

The audible indication consists of two signals from the loudspeaker. One a high pitched sound and the other low pitched. When the ship is "on course" the signals are equal in volume, but if the ship veers to one side, either the high or low tone predominates and calls the attention of the pilot to the visual indicator which tells him how far off course he is running.

It is undoubtedly possible that with this new system of Marconi's, the Nantucket Lightship disaster would not have occurred.

Chart illustrating radio manufacturer failures, according to figures by Dun & Bradstreet.

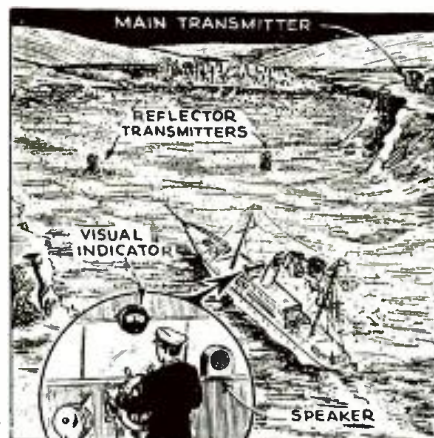
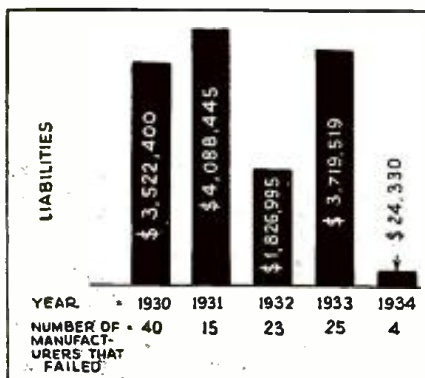

# RADIO PICTORIAL



**Radio and Rectifier Tubes**

**R**EALIZING the need for a device which would simplify the explanation of the action within a vacuum tube, a well known concern constructed the triode demonstrator shown above. The elements glow.

**I**N THE tank demonstration shown below, General Weygand of the French army gave orders to the entire fleet of tanks by means of radio equipment. The vertical antennas on the tanks can be plainly seen.

Photo—Press Photos.

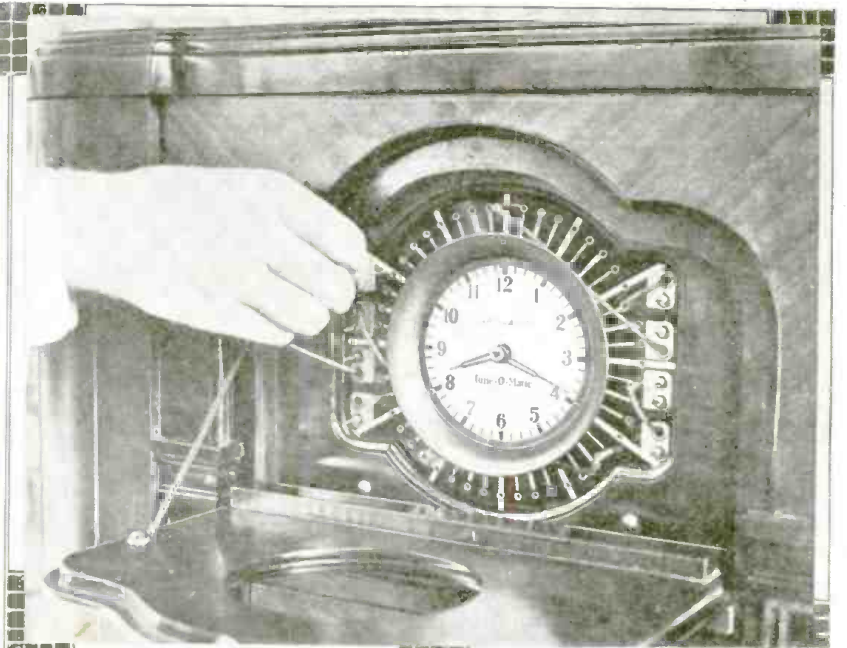

**O**NE OF the prominent radio manufacturers has just placed on the market a receiver using the device shown above. This is a time control which turns the radio on and off and tunes in different stations according to a pre-selected schedule.

Photo—Atwater Kent.

**T**O THE right is shown the "phonofiddle", an English invention which produces violin-like sounds from a speaker. The instrument is played like a 'cello, the sounds being transferred into electric currents by means of a microphone pick-up unit.

Photo—Amalgamated Press, Ltd.



**A**T THE super-power station at WLW, an unusual type of lead-in is used. As we have mentioned before in RADIO-CRAFT this lead-in consists of an R.F. transmission line known as the concentric type which consists of a 10 inch aluminum tube approximately 750 feet long. Supported in the exact center of this tube is another tube approximately two inches in diameter. The outer tube is grounded very carefully at intervals along its entire length.

Photo—Crosley Radio Corp.

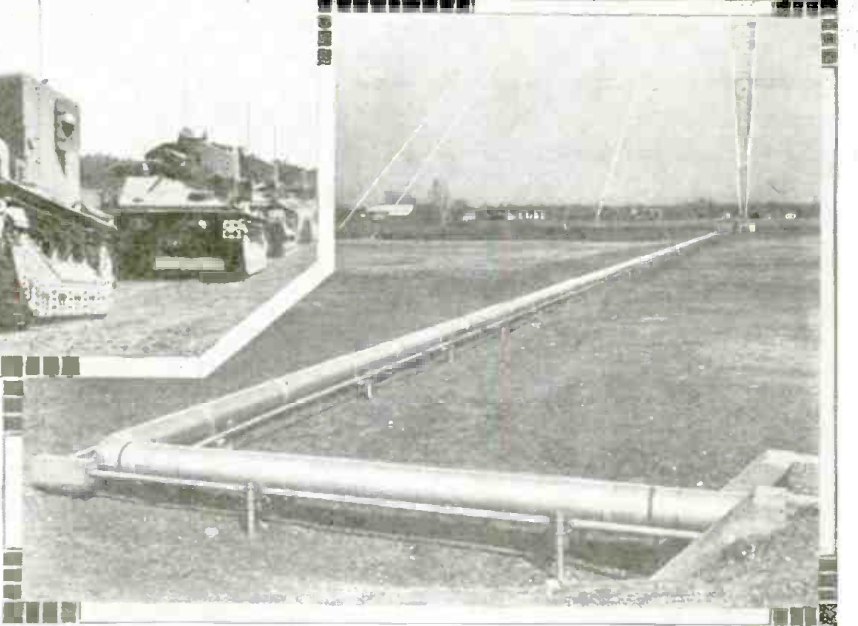

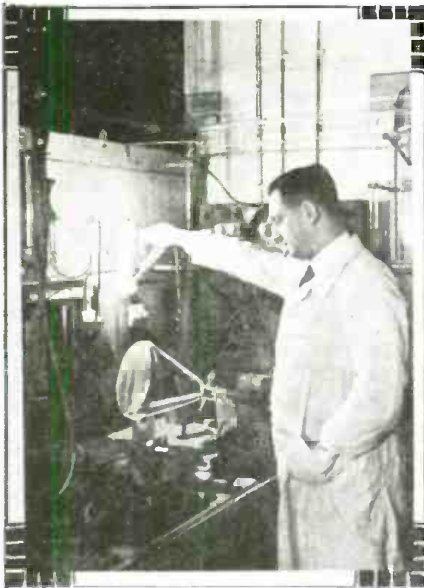

**I**N THE three photos at the left, right and below are shown three views of the latest German television receiving equipment. The developments consist of the design of high quality cathode ray tubes which produce better images than previous types. The tubes are also designed to have much longer useful life and synchronization has been simplified. A number of switches and tubes in the television receiver have been eliminated which brings the cost down so that it compares with broadcast receivers.

Photos--Dr. A. Gradenwitz.

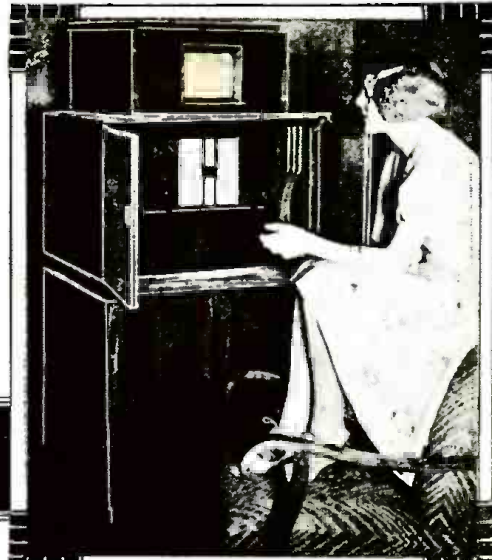

**R**ADIO played an important part in the stratosphere flight of the National Geographic Society and the Army Air Corps. Below is shown the interior of the gondola with some of the vacuum tube devices for recording cosmic rays. In the lower right corner is the special NBC equipment for the flight.

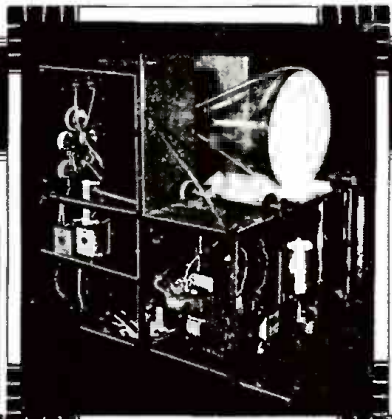

**R**ADIO receivers in the form of globes have appeared on the American market, but the English receivers shown below differ in mechanical construction from their American predecessors. The entire globe turns thus tuning in a station.

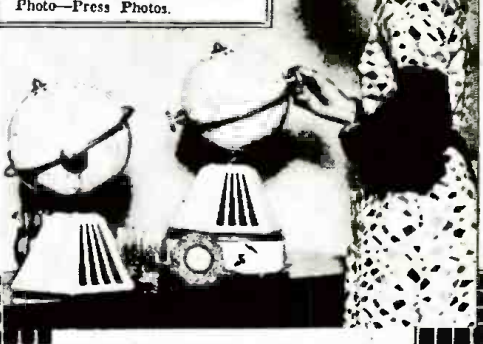

**T**HE PHOTO below shows an interesting use of P.A. equipment at a horse race on the Tanforan Track, San Bruno, Calif. The judges' stand at the finishing line was equipped with a series of horns and a P.A. amplifier for announcing the winners of the various races.

Photo--Press Photos.



# THE LATEST RADIO EQUIPMENT

## THE PHONOSONE (No. 540)

IN THE March, 1934 issue of RADIO-CRAFT Hugo Gernsback described an improved type of his osophone or bone-conduction headphone known as the "Phonosone." The unit described in the article has now undergone further structural developments and is now commercially available.

The phonosone is a deaf-aid that permits many of those who are hard of hearing to enjoy radio programs. The phonosone connects to the output circuit of a radio set. The diaphragm of the phonosone presses solidly against the head. Vibration of this diaphragm is carried directly by conduction through the bony structure of the head to part of the auditory nerve system. In this manner the phonosone is often effective in enabling radio programs to be heard where failure has been experienced in the use of the usual earphone that depends for its operation upon the vibration of the air between the earphone and the ear.

The unit illustrated is solidly constructed and contains the feature of the balanced armature utilized in the original design.



The phonosone deaf aid. (No. 540).



Close-up of phonosone. (No. 540).

## A COMPLETE P.A. SYSTEM (No. 541)

THIS system is a high-gain 4 tube amplifier, furnished complete with microphone and phonograph pickup. Microphone button current is furnished from the amplifier, as well as field excitation for 2 dynamic reproducers. A 25 ft. microphone cable and polarized plug are included. A single 8 in. dynamic reproducer with 25 ft. cable and plug is supplied. An extra speaker, mounted in a combination half carrying case, which snaps in place on the cover, can be obtained. The specifications are as follows: tubes, one 79, two 42s, one 80; power consumption, 70 W.; power output, 7 W. Weight, 22 lbs.; size, 9 x 13½ x 18 ins.



Complete P. A. system. (No. 541).

## A METER PROTECTOR (No. 542)

TO PROTECT delicate and expensive meters against high-frequency overloads and R.F. surges an adapter



Meter protective unit. (No. 542).

## A call-system amplifier. (No. 544).



has been developed which permits a high quality bypass condenser to be connected in shunt to the meter, at its terminals. The condenser is a 1000 V. test unit with a capacity of .02-mf. This condenser is supplied with two "wings" that clamp under the meter terminals.

## REPLACEMENT "B" UNIT VIBRATOR (No. 543)

VIBRATOR-TYPE rectifiers have much to recommend them but early models failed to stand up very long. To meet this condition a pioneer organization in the design and manufacture of this type of mechanical rectifier concentrated on the production of replacement units. As a result, there are now available 7 types of vibrator units suitable for replacement in more than 55 makes and models of radio sets.

The unit illustrated is enclosed in a sound-absorbing lead case. The cast iron frame makes it possible to utilize a coil requiring approximately one-half the current of other vibrator units.

Another unit in the replacement series is suitable for operation in Majestic 32 V. (farm lighting) radio sets. This unit is designed to eliminate the blowing of fuses and the sticking of vibrator points.

## A 10 W. A.F. AMPLIFIER (No. 544)

FOR medium-size factory call systems, halls, and churches seating less than 1,500 persons there is available a 3 stage, 10 W. microphone and phonograph amplifier. All the components are contained in a ventilated steel cabinet. Two volume controls—one for microphone and one for phonograph, power switch, and a pilot light are located on the front panel. One 10 in. dynamic reproducer with connecting plug and 6 foot cable is supplied. Field excitation for 1 speaker, and microphone current for 1 microphone are obtained from the amplifier.

Further specifications follow: Uses one 2A6, 2-53s, and one 5Z3. Power consumption, 85 W.; power output, 10 W. Input for a 2 button microphone, and 5,000 to 10,000 ohm

## A new tube tester. (No. 545).



pickup; output impedances, 2, 3, 6, and 500 ohms. The gain is 72 db. The size is 9x9x12 ins.; weight 16 lbs.

## A VERSATILE TUBE CHECKER (No. 545)

ENGRAVED on the panel of this tube checker are reference numbers for use in testing 96 types of radio tubes; a separate chart contains equivalent checking numbers for an additional 100 tubes. Actually there are only four sockets on this instrument but all present-day tubes can be tested; the circuit and panel are so arranged that future tubes may be conveniently tested. The values of tubes in terms of poor or good are indicated on an English-reading scale. The D'Arsonval-type meter is prevented from damaging without recourse to fuses. Shorts are indicated on a neon tube. Cathode leaks up to 1 megohm are shown. Line voltage adjustment between 105 and 125 V. is provided. The ballast tube within the instrument acts as both a rectifier and a current-limiting device.

## HIGH-IMPEDANCE NOISE SUPPRESSORS (No. 546)

A HIGH-QUALITY spark suppressor of the inductance type has been developed for use in suppressing automobile ignition noises. The feature of this unit is its ratio of A.C. to D.C. resistance. The inductance value is rated at .017-hy. at 1000 cycles. It is most effective as a choke at 500 kc.; the D.C. resistance is 120 ohms. The coils, mounted in a bakelite casing, have varnished-paper insulation between each layer, are vacuum impregnated and compare in design, workmanship, and material, and resistance to heat and moisture, to high-grade ignition apparatus. This suppressor is available in kits to meet all requirements.

## A NEW COUNTER-TYPE TUBE TESTER (No. 547)

THE single meter used in this tester indicates on a shaded, two-color scale the condition of the tube under test in terms of good or poor. Bart-type controls are used; one operates the line voltage rheostat, and the other, the selector switch.

A line voltage control A.C. meter is incorporated. Provision is made for testing cathode and grid for leaks and shorts. A push button provides double current readings for conductance tests.

## A SOCKET PUNCH, (No. 548)

SERVICE Men and experimenters who have dedicated a good portion of their lives to devising ingenious but nevertheless time-con-

Service-type "B" vibrator. (No. 543).

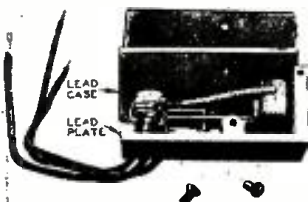

Name of manufacturer of any device will be sent on receipt of a self-addressed, stamped envelope. Kindly give (number) in description under picture.



A noise suppressor. (No. 546).



Counter-type tester. (No. 547).



Above, chassis-hole punch. (No. 548).

Below, a direct-reading slide-wire dual-resistance rheostat. (No. 549).



suming methods of drilling large holes in chassis for tube sockets will welcome the punch illustrated. The punch is placed over the proper location, you swat the punch with a hammer, and lo! the chassis is ready for the socket. Standard-size socket punches take both wafer and the new clip-type sockets. There are available standard-size electrolytic condenser punches for making holes to fit the 2 standard sizes in inverted-type condensers. Special punch sizes are available.

The special steel used in the punch permits holes to be made in all sheet metals up to and including 16 gauge. An ordinary 2 or 3 lb. hammer is all that is necessary to knock out all punches. It is of interest to note that holes may be knocked out of a completely assembled chassis without injuring any of the mounted components.

### FUSED RESISTANCE INDICATOR (No. 549)

THE resistance indicator illustrated is an ordinary variable wire-wound resistor covering the ranges of 0 to 10,000 ohms, and 0 to .01-megohm. Each range is provided with a resistance calibration so that for any position of the slider the coil resistance in use is known. The ball-bearing sliding contact shows minimum wear of the wire. The single slider may be operated on either resistance range. Additional ranges may be obtained by the addition of resistances. The fuse protects the unit against overloads.

This dual resistance indicator may be used as a calibrated rheostat, potentiometer, temporary standard resistor or voltage divider. Units of this type are useful in measuring an unknown resistance value by the substitution method.

### A 1 METER TUBE CHECKER (No. 550)

A FEATURE of this tube checker is the dual service performed by the single meter. This unit is of English-reading type for indicating the suitability of tubes; by pressing a button the same meter is connected into circuit to indicate the correct compensation for the existing line voltage, as the 4th slider is adjusted. This slider makes connection to the correct tap, out of 19, taken from the transformer primary for variation of the line voltage within the range of 100 to 130 V.

The 3 remaining slider switches connect to contacts that provide separate and correct voltage distribution to all the elements of all types of tubes, regardless of their termination in the tube base. The correct setting, from 1 to 23, is determined by reference to the chart which covers 147 types of tubes without recourse to adapters. The wiring within the unit is cabled. The tester measures 10 x 15 x 6 1/2 ins.; weight, 13 lbs.

### A POWER SPEAKER (No. 551)

TO ELIMINATE the complications of installation and to insure correct monitor speaker operation a unit has been developed which consists of a high-grade dynamic speaker, bridging amplifier, rectifier and volume control all incorporated in a single cabinet. This reproducer may be operated from practically any type of transmission line between 1 and 500 ohms. The amplifier unit supplies field current for the dynamic speaker. The amount of power taken from the speaker line is so small that the impedance match of back-stage speakers is not upset despite the fact that the volume of the monitor speaker can be varied throughout a wide range. This unit utilizes one type 43 tube and a 25Z5. The instrument measures 5x7x7 ins.

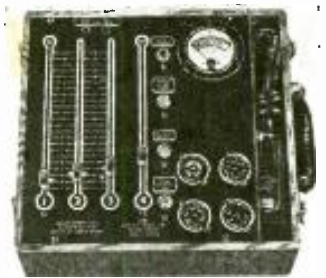

Slider-type tube checker. (No. 550).

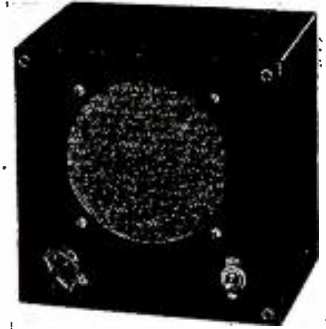

A power speaker. (No. 551).



A Bacchanalian radio set. (No. 552).

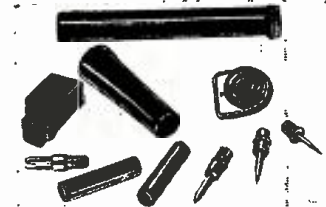

Assorted service aids. (No. 553).

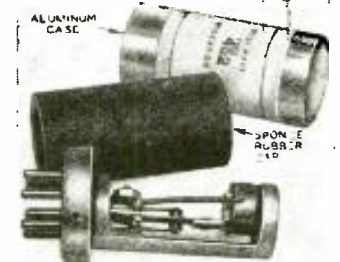

A replacement vibrator. (No. 554).

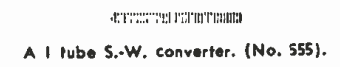

A 1 tube S-W. converter. (No. 555).

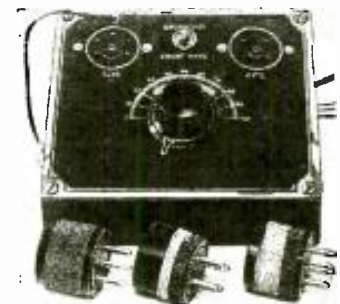

### "COCKTAIL" RADIO SET (No. 552)

WE WONDER whether it was a political speech by radio that instigated the Bacchanalian design of the ultra-midget radio set illustrated. This radio receiver is guaranteed to permit the most thirsty owner to quench his thirst if the radio program becomes too dry.

Merely swing open one pannier at the side of the cabinet and remove from 1 to 6 glasses. You fill them from the contents of bottles in the second pannier marked rye, scotch and bourbon. The utility of the cabinet is matched by the efficiency of the chassis, which incorporates a 4 tube A.C.-D.C. super-heterodyne circuit with a wave-changing switch that permits the reception of police calls on wave lengths below 200 meters. The receiver utilizes one type 66 tube, 1 6C6, 1 43 and 1 25Z5. The ballast resistor is contained in the power cord. A dynamic reproducer is employed. The frequency range is 550 to 3,300 kc. Unless the set is operated in a "poor" location, the built-in antenna is the only type of pick-up required.

### NEW SERVICE AIDS (No. 553)

ONE manufacturer has just announced a new series of molded products of interest to the Service Man and experimenter. A 2 piece molded test prod hand with a hollow top that unscrews to provide space for extra points has been designed. The wire lead is out of the way, thus reducing hand effects in neon lamp, high-resistance and high-frequency tests. This design also insures protection in high-voltage testing. Removing the handle top provides a short-length test prod for use in restricted spaces.

The second handle is of short-length type for holding the manufacturer's type D point and accommodates the 2 circuit wires for current measurements.

A third handle is designed for point-to-point testing and general use as an insulated handle at the end of a wire.

The fourth is a handy finger-grip molded handle especially useful in contacting plug-in socket terminals. This item is handy for both vertical and horizontal panels.

Four test points for use in the molded handles are described as follows:

The D point is a double-circuit type for use with series circuit.

(Continued on page 239)



Dr. Thomas operating the Marimbalite

# THE MARIMBALITE

## A MUSICAL INSTRUMENT UTILIZING PHOTO-CELLS

The cold cathode grid-glow relay tube is combined with the photoelectric cell in this interesting musical instrument.

DR. PHILLIPS THOMAS\*

**M**ANY commercial applications have been made of the principle of operating electrical devices by means of a beam of light. An outstanding application, for example, is the talking light beam, by means of which it is possible to talk over relatively great distances by means of a modulated light beam focused on a photoelectric cell, followed by a suitable amplifier and speaker. A simple, practical device of this type appeared in the September, 1934, issue of RADIO-CRAFT, on page 140.

Other commercial applications of light control of mechanical or electrical objects are: the control of lights by the intensity of light, such as fog and smoke detectors, electric sign illumination, etc.; the control of mechanical devices such as bean sorters, tobacco sorters, paper quality and thickness control and many others too numerous to mention here.

The practicability of this type of control depends upon the reliability and permanence of the devices involved, as well as upon their cost and relative weight and size.

Of course, the photo-cell or photoelectric cell forms the nucleus of all such devices. This tube will pass current when light or similar radiation impinges upon it, the amount of current passed depending upon the radiation intensity received by the photo-cell. However, the maximum current obtainable with practical sizes of photoelectric cells, and practical illumination intensities, is of the order of microamperes; and a rugged, dependable

\*Research Engineer, Westinghouse Elec. & Mfg. Co.

### ARE YOU INTERESTED IN ELECTRONIC MUSICAL INSTRUMENTS?

In a number of past issues, RADIO-CRAFT has presented musical instruments of different types which use electronic devices as a means of producing, generating, or controlling tones. These instruments represent a branch of radio which has sprung up in the past few years and is receiving much interest from those fans who are interested in experimenting with such circuits and devices. If you are one of these experimenters, the unique construction and principles employed in this instrument will give you some new ideas in electric musical instrument construction.

electromagnetic relay to be operated by the photo-cell current itself, is not available. Hence it is necessary to amplify this current in some way. (While on the subject of photoelectric tubes, it might be well to mention that more detailed information on the subject appeared in RADIO-CRAFT of August, 1934, page 86—(The P.E. Cell, by A. J. McMaster.—Ed. Note.)

As long as this amplification was accomplished by means of standard radio tubes, several difficulties were met. In the first place, the use of more

than one step of amplification required that the incident light or radiation be made intermittent, since one cannot make a practical and inexpensive direct current multi-stage amplifier. Again, the filament and plate excitation, and the grid bias, required either batteries or power-packs, either of which was bulky and expensive.

With the advent, however, of the so-called "cold cathode grid-glow tube," these drawbacks disappeared, and the "light relay" began to assume considerable commercial importance. The cold cathode grid-glow tube is used as a relay tube; that is, it is an "all-or-nothing" proposition; either it passes practically zero current, or it passes all the current possible under the given conditions of applied voltage and circuit impedance, depending upon the voltage applied to its grid or control electrode. It is a low grid current device, and can be operated ("turned on" or "shut off") by the change in phototube current occurring when a light of normal intensity is pointed at, or away from, a photo-cell.

The combination of a photoelectric tube, a cold cathode grid-glow tube and a small telephone relay, then, is able to replace that of a photoelectric cell, two or three amplifier tubes with their transformers and batteries, and a means of rapidly interrupting the incident light beam. The complete device is cheap, rugged, and of long life, and is finding quite extensive practical application. To name a few typical uses of this light relay: burglar alarms, door-opening devices, counting and sorting, color-matching, elevator alignment, and traffic control installations.

One of the most practical and interesting uses for photoelectric devices is for musical instruments of the type generally referred to as "electronic" musical instruments. A new device of this type is a light operated marimba which has been given the appropriate name of Marimbalite.

#### The Mechanism

The Marimbalite was developed as a means of showing an audience the use of light beams as long, weightless levers for operating electrical switches; also to show how simple and compact is the photoelectric-grid glow light relay. The

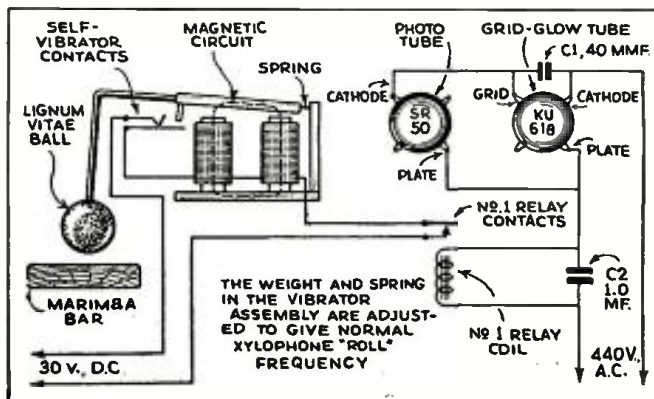

Fig. 1

The circuit of one of the hammers with its photo-cell control. Note the connection between the photoelectric tube and the grid-glow relay.

Here is a spectacular instrument for stage work. It sounds like a marimba—in fact it has all the parts of a genuine marimba, plus a multitude of photoelectric and grid-glow tubes which perform the intricate task of "rolling" the notes. The musician plays this instrument by aiming spot lights on the photo-cells instead of wielding the usual hammers. A glance at the cover illustration

of this issue will give an idea of the flashy appearance of the instrument in a typical stage setting. Note the spot lights which are similar to flashlights except for a more efficient focusing arrangement. The bass notes are located on one panel while the melody or treble notes are on the other, and chords are possible on the "bass" panel, due to electrical connection.

instrument has, as a foundation, a standard four-octave marimba. In order to provide accompaniment for the melody being played, in absence of an orchestra, the two lower octaves are used to form set chords, four notes in each chord. The melody is carried on the two upper octaves.

Each note or reed of the marimba is equipped with a special vibrating hammer consisting of a direct current electro-magnet, whose armature terminates in a small lignum vitae ball. When the magnet is energized, the ball is drawn down and strikes the marimba note. On the way down, however, the circuit to the electromagnet coil is opened by a projecting piece on the armature, much as a vibrating doorbell functions; thus the repeated, rapid vibratory note or "roll" is produced.

An examination of the circuit, Fig. 1, will show how this action is accomplished. The light, focused upon the photoelectric tube, produces a change in the grid current of the grid-glow tube, which produces the "trigger" action mentioned above. This change in current actuates the coil of relay, No. 1, which closes the circuit through the coils of the vibrator. Then, as mentioned before, this vibrator circuit is intermittently broken by the contacts marked "self-vibrator contacts" in the circuit. The tension of the spring of this vibrator unit and the length of the bar control the speed with which the "roll" takes place. The photo-tube and the grid-glow tube are actuated from a 440 V. transformer connected to the A.C. line, while the vibrator is fed with 30 V. D. C. from batteries or a rectified source.

Each note and half-note of the upper or soprano two octaves, has placed directly above it a photoelectric cell and a grid-glow tube, with the associated small telephone relay. When light strikes the photo-tube, the grid-glow tube lights and energizes the telephone relay, which closes its contacts, causing the desired marimba tone to be rolled as long as the light is aimed at the photo-tube.

In addition to the photo-tube and grid-glow units on the two upper octaves, there are nine additional tube and relay units. Each of the nine corresponding telephone relays has four contacts instead of but one, so that

allowing the light beam to strike any one of these nine photo-tubes energizes four vibrators, and rolls the corresponding four-note chord.

#### Playing the Instrument

The photographs and the cover illustration show how the instrument is played. Two focused lights, similar in construction to flashlights (but receiving their current from the power supply for the remainder of the instrument) are used for playing it. One of these lights is held in the right hand and plays the melody, while the left hand unit is aimed at suitable "chords" to accompany the melody. The player faces the instrument and stands at a distance of about ten feet from it. The writer is able to play almost any instrument by ear, and hence has had little difficulty in becoming quite proficient upon this one.

While this instrument was designed and constructed primarily as a demonstration of the possibilities of control by light beams, it is a practical unit which is flexible in operation and permits a capable musician to render al-

most any selection that comes within the scope of the marimba. It gives a spectacular demonstration and is thus suited for stage performances. But, most important, it shows the possibilities of the light beam and photo-cell as a means of controlling mechanical objects and should be fertile food for the experimental mind.

#### Bibliography

With the above point in mind, the following list of articles which have appeared in RADIO-CRAFT concerning electronic musical instruments is given. While only a few of these instruments are photo-cell operated, they are interesting references for anyone interested in the various types of instruments that have been produced up to this time.

- Radio Organ of a Trillion Tones, by A. Lesti  
January, 1931, page 402.
- Martenot—A New Radio Music Instrument  
March, 1931, page 531.
- Radio Violin, by F. Christini  
December, 1931, page 358.  
(Continued on page 234)

The appearance of the complete instrument which is built from a standard marimba.

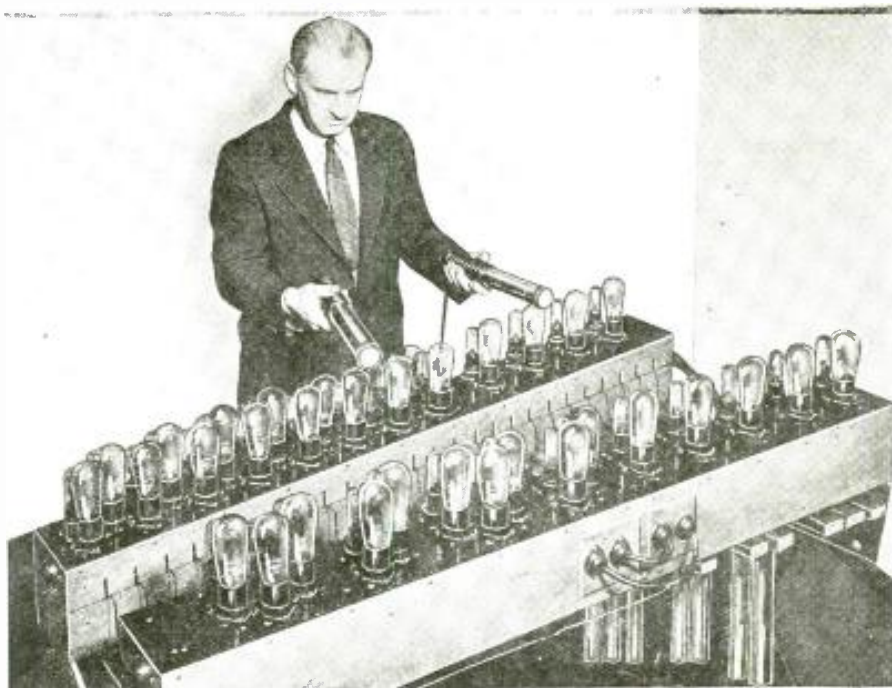

# HOW SHORT WAVES AID RADIO TELEPHONY

**Y**EARS ago, if a person in the United States desired to communicate with someone in a country on another continent, he faced one of two alternatives as a means of contact. One was the method of writing and mailing a letter and waiting anywhere from 2 weeks to 3 months for a reply, or else by cable which, by contrast, was considerably more rapid (and is still in popular use) and involved only a delay for reply to the extent of 24 to 48 hours.

Since then, however, radio equipment and the short-wave field have been so highly developed that it has been applied to telephone communication for connecting countries separated by vast stretches of water. Nor is short-wave 'phone communication limited to that accomplishment only, since it is now also possible to contact, in this manner, any major steamship or liner that plies the almost countless miles of water between continents. Some of these liners which have the necessary special short-wave radiophone equipment for ship-to-shore communication are: the Leviathan, the Bremen, Europa, Rex, Ballin, Olympic, Deutschland, New York, and the Conte De Savoia, besides a few others. The procedure for establishing 'phone communication from a liner (installed for the convenience of its passengers) is somewhat similar to the pro-

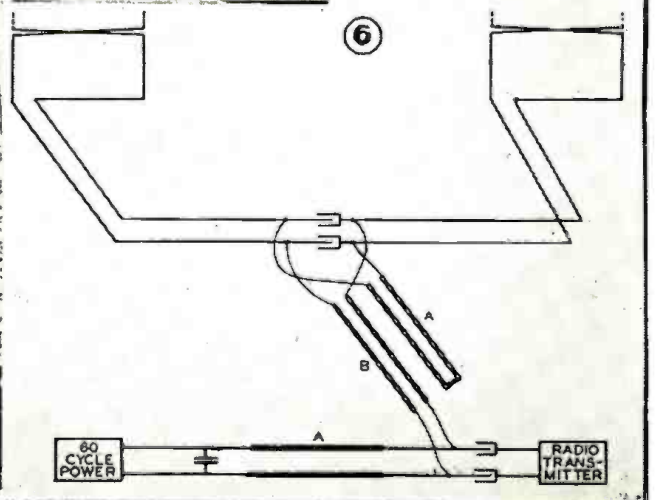
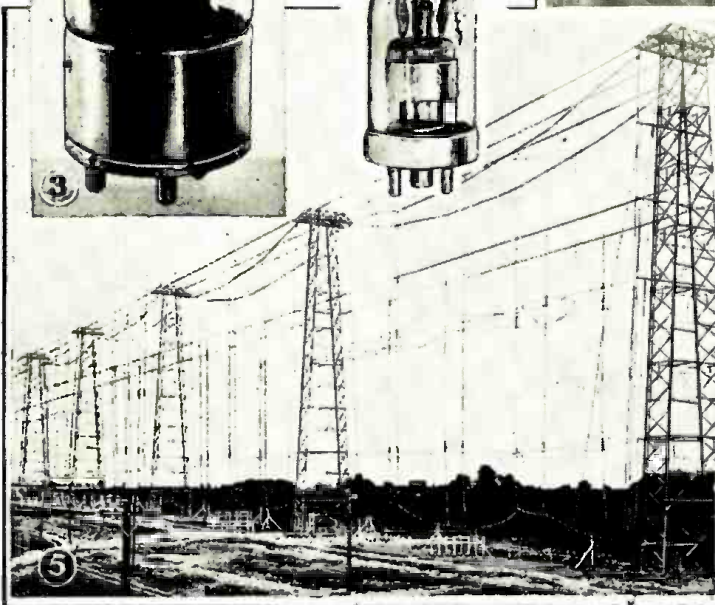
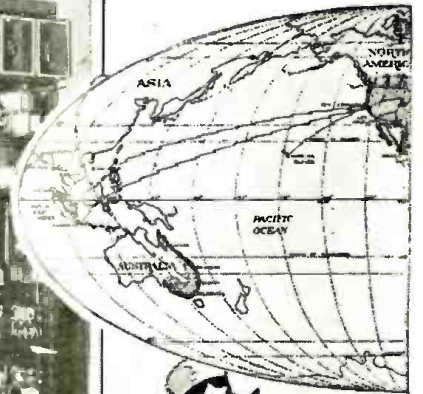
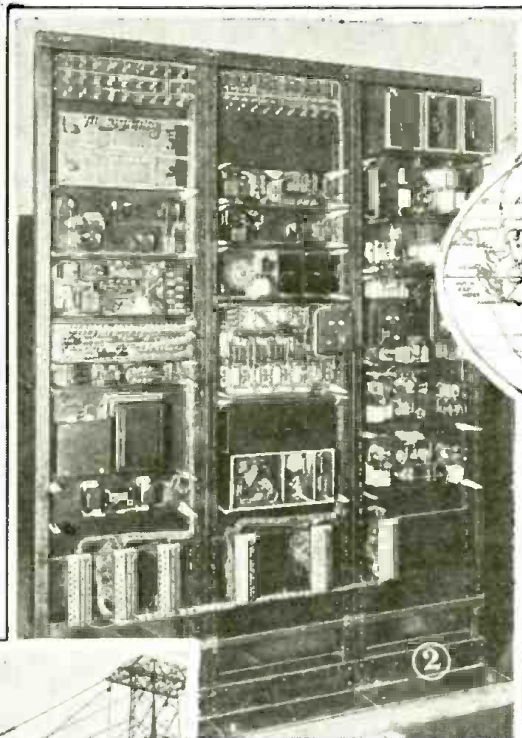
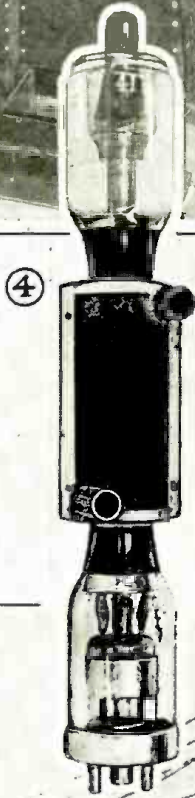
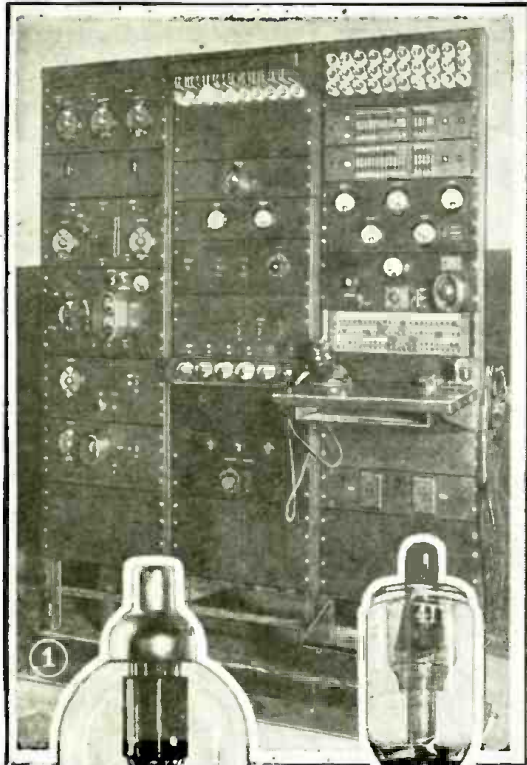



# INTER-CONTINENTAL

J. T. BERNSELEY

cedure which is to be described. However, such communication from a ship is secondary to the regular "wireless" traffic which involves the safety and maneuvering of the ship and therefore, at times, may involve some slight delay in establishing contact to the shore 'phone station. We are all aware, by this time, that telephone contact can be established with any important country in the world, but how many realize that the major equipment employed is fundamentally similar to that used by short-wave amateurs?

Perhaps this can be more readily visualized if we were to explain that for bridging the vast oceans which separate each continent, a powerful short-wave transmitter and receiver are employed at strategic points in the various countries. And, of course, this equipment is more elaborate and highly developed besides being tremendously more powerful than that used by amateurs.

Consequently, when Mr. Jones in St. Louis (for example), a very busy executive who is in haste to obtain a report from one of the company's representatives in, let us say, Berlin, picks up the telephone and expresses his desire to communicate with Mr. Smith in Berlin, the long-distance operator immediately gets busy and within a few minutes Jones and Smith are conversing together via the telephone.

The operator's procedure was to establish contact, first with New York, and then with the transmitting station at either Rocky Point, (Continued on page 239)

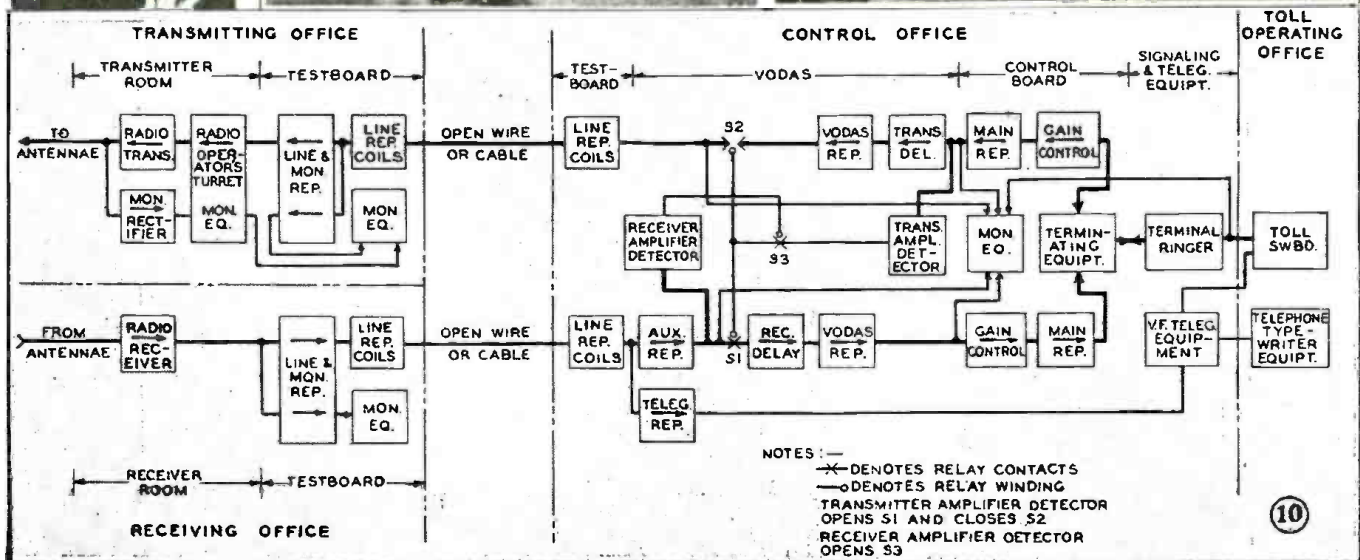
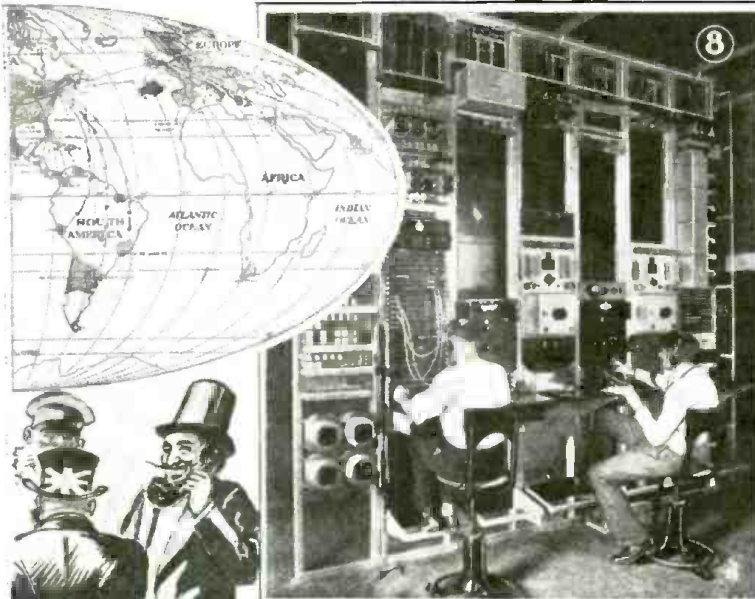
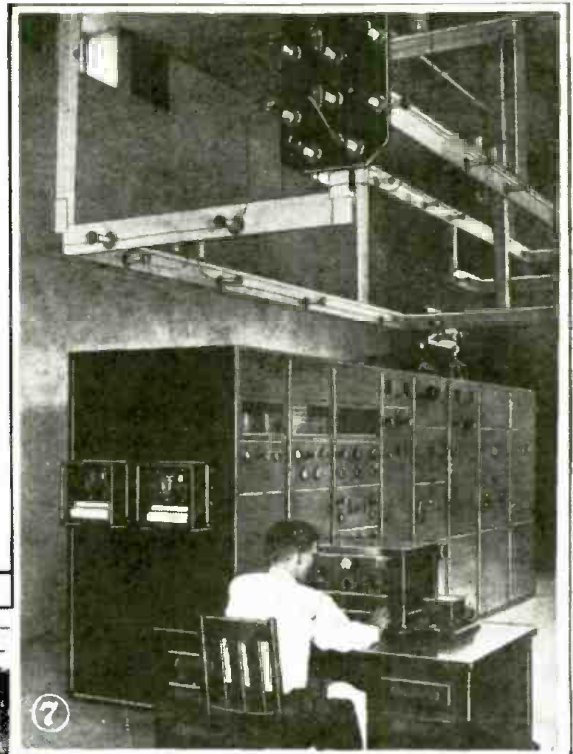

# A POWER-BOOSTING ANTENNA SYSTEM

This aerial for broadcast stations increases the signal intensity approximately double in areas where desired and moves the fading area to a considerable distance from the station without increased power.

R. N. HARMON\*

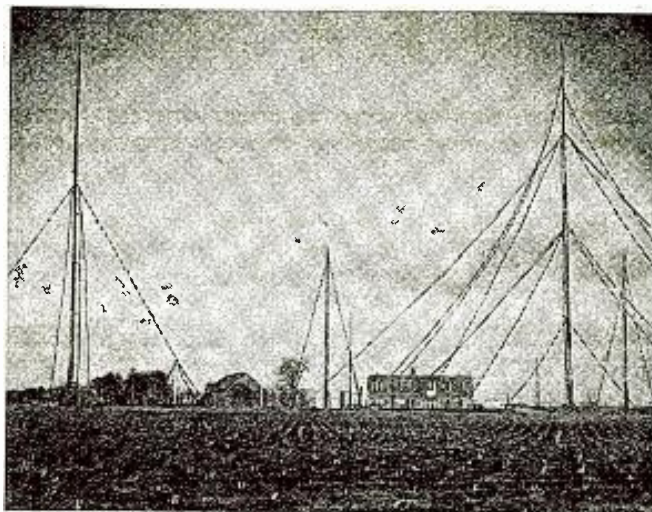

Fig. A—The exciter and reflector aerials may be seen in the foreground.

AS a means of demonstrating the marked effect of directional aerials on radio transmission and reception, this description of a unique type of radiator in use at station KYW is presented. While the methods employed deal entirely with broadcast transmitters, the resulting increase in communicating distance through the use of directional aerial methods applies also to receivers. From this angle it is of interest to the radio fan to know just what results may be expected from a well designed directional aerial. While directional antennas are used for long distance reception for transoceanic telephones and other commercial communications, they have been almost entirely neglected by the amateur, especially on the broadcast band.

## The Concentrator Aerial

The aerial in use at KYW known as the exciter or concentrator aerial, tends

\* Radio Division, Westinghouse Elec. & Mfg. Co.

Fig. 8  
Looking up the exciter aerial pole.

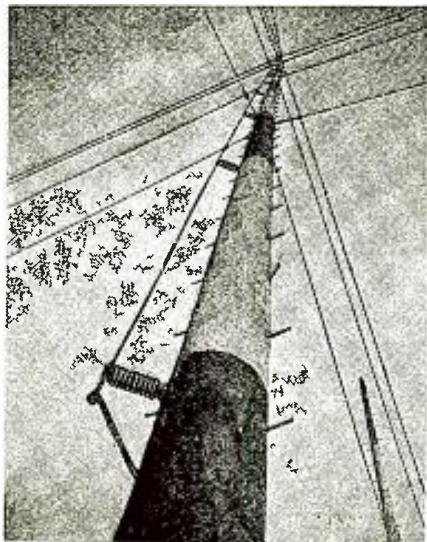

to bend down the radio waves coming from the radiator, flatten them so that they are intensified over the useful area of the station. In operation, it acts somewhat as a prismatic lens, encircling a light source, bending down and flattening the light rays so that they are confined to useful angles.

By improving the ground wave of the station and increasing its sky wave, fading is said to have been overcome in the service area of the station. Also the signal intensity within this area has been increased almost double, without any increase in the power output of the transmitter.

The main antenna is a vertical conductor 204 ft. high mounted on a 200 ft. spliced wood pole with large porcelain standoff insulators. The reflector antenna is also a vertical conductor but is only 150 ft. high. It is a vertical conductor mounted on one of the four original 100 ft. antenna poles with a 50 ft. duralumin tower mounted on top of the pole. The reflector is spaced  $\frac{1}{4}$  wavelength (approximately 250 ft.) behind the exciter unit. Both the reflector and the exciter are loaded with inductance at the ground end and grounded

Fig. 1

The field strength pattern for the concentrator aerial for differently spaced reflectors. Note that the greatest signal strength occurs when the reflector is .25 wavelengths back of the exciter.

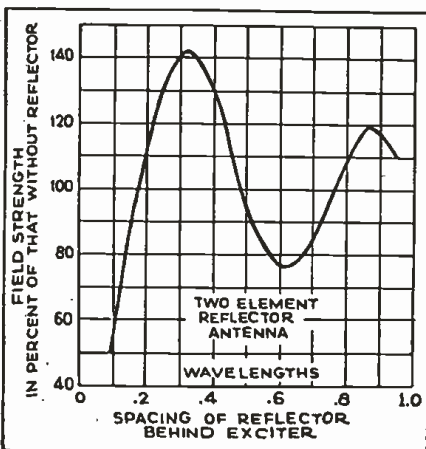

so as to operate at  $\frac{1}{4}$  wavelength.

The reflector antenna is not directly excited from the transmitter but picks up its radio frequency energy by absorption from the field of the exciter antenna. Theoretically, the best spacing between the exciter and reflector aerials for the largest ratio of front to back signal is .32-wavelength. This is for a reflector which is not directly excited from the transmitter. For a reflector directly excited, the best spacing is .25-wavelength. The spacing of .25-wavelength was chosen for KYW because the reflector was somewhat lower in height than the exciter antenna and there was some doubt as to whether or not it would have to be directly excited from the transmitter.

For a directly excited reflector, as stated before, the spacing of .25-wavelength or 90 electrical degrees in phase is correct. Likewise, the spacing of .32-wavelength is correct for the indirectly excited reflector, because for this spacing the resultant field from the exciter antenna at the reflector antenna is lagging in phase with respect to the radiation field of the exciter antenna at the reflector antenna. The field set up by the current in the reflector antenna retards in phase as it travels towards the exciter antenna. On arriving at the exciter antenna it is exactly in phase with the field of the exciter antenna and therefore adds to the field strength of the latter.

Thus, in a direction directly ahead of the exciter antenna the fields of the reflector and exciter will be completely in phase and thus give the strongest signal. In a direction directly behind the reflector antenna the fields of the tube radiators will be out of phase and therefore tend to cancel each other.

In the actual operation of such an antenna system, the phase of the two fields can be changed by either spacing of the two antennas or the tuning of either one with respect to the other. Once the antennas have been erected

(Continued on page 241)

# 12 WAVE RADIOPHONE

An ultra-short-wave "... radio path is equal to a good wire circuit", concedes England, daily utilizing its 12 wave, 5 meter experimental radiophone across the Bristol Channel.



General view of ultra-short-wave radio station.

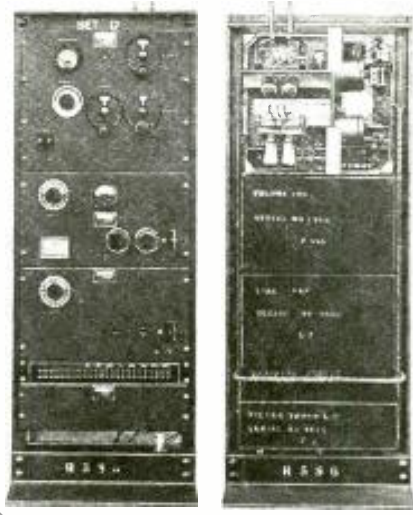

Super-regenerative 5 meter receiver panel.

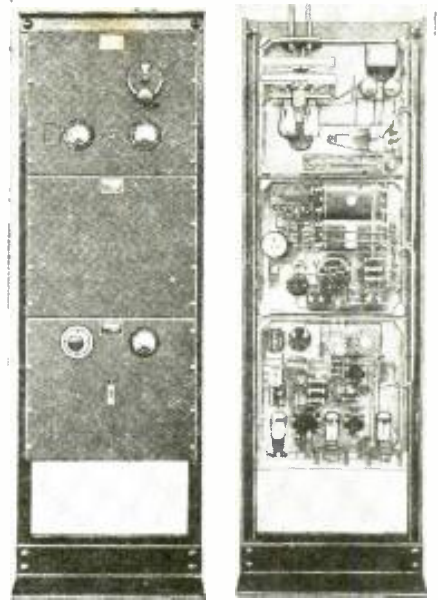

The rack-and-panel, A.C.-operated transmitter.

**T**HE provision of telephonic communication between points separated by a stretch of water has always been a problem confronting telephone engineers. To a certain extent

this problem has been solved by the use of submarine cables, but these are expensive to install and there is always the risk of the cable being damaged after laying, with consequent

interruption of the service and expense in repairs.

The provision of such facilities by radio has involved, in the past, large and expensive equipment and hence has been ruled out for short-distance work on the score of cost. Recent researches on the behavior of waves below 10 meters in length, however, have shown that the use of such wavelengths offers

*(Continued on page 237)*

# TUBELESS P. A. SYSTEM

This practical call system, installed in the dispatching offices of the I.R.T. subway lines in New York City, uses no vacuum tubes, yet supplies loudspeaker volume to 60 speakers spaced out over a distance of 23 miles. It uses a simple step-up transformer and a storage battery for supplying the current variations from a 2 button carbon microphone.

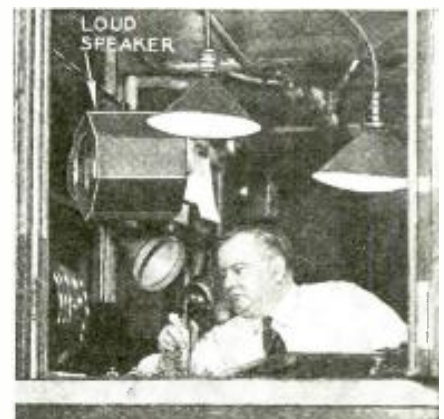

Fig. A, above  
One of the dispatchers' offices of the I.R.T.

Fig. 1, below  
The terminal equipment of the call system.

**W**E HAVE become so accustomed to the use of vacuum tubes wherever sound is increased in volume that it is difficult to realize that practical call and P. A. systems can be made without their use.

Those who date their radio experience back to the days before practical vacuum tubes, however, will remember that numerous articles were written around the subject of amplification by either mechanical or electrical means. Some of these systems actually worked; one of the best known using step-up transformers with a crystal rectifier to boost the sound before it reached the headphones.

This same antique system of "amplification" has found a commercial application as a call system in the Interborough subway system in New York

*(Continued on page 233)*

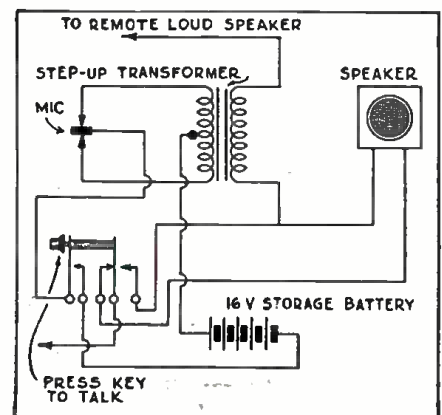

# INTERNATIONAL RADIO REVIEW

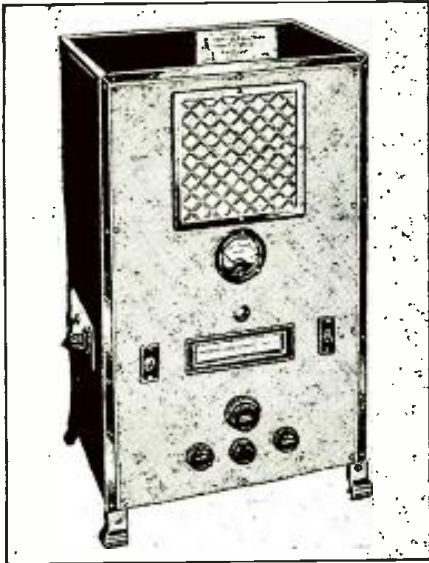
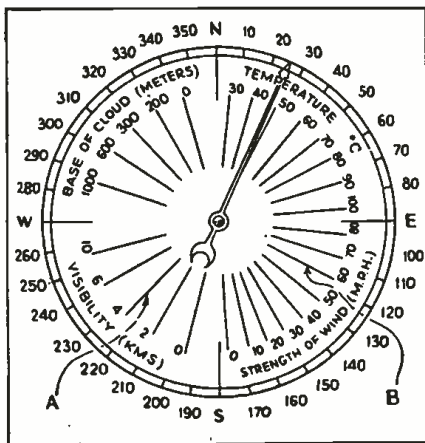
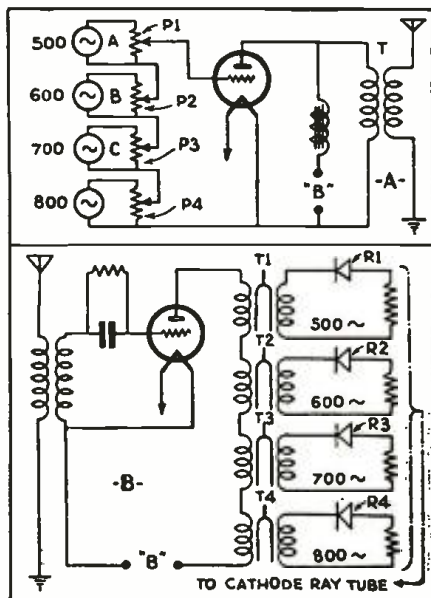

Fig. A  
The appearance of one of the English hospital sets.



Figs. 1 and 2  
The dial of the radio indicator and the transmitter and receiver circuits.



HERE is what the radio experimenter has been wanting for a long time—a semi-technical review of the thousands of new ideas which are continually appearing in overseas publications. Each month there are received at the offices of RADIO-CRAFT hundreds of daily, weekly and monthly magazines originating from all over the world.

SINCE the cost of subscribing to each of these would be prohibitive for most radio men, we have arranged with technical translators to prepare for our readers reviews of all the really important, new developments illustrated and described each month in these publications.

NOTE that the only available information is that which is published; the experimenter must adapt the ideas to whatever equipment he has on hand.

## RADIO IN BRITISH HOSPITALS

A VERY notable service being offered gratis by the Radio Manufacturer's Association to hospitals in England was described in a recent issue of THE BROADCASTER & WIRELESS RETAILER. One of the special sets which were designed for use in hospitals is shown in the accompanying photo, Fig. A. This Association is setting up a national fund in cooperation with the British Hospitals Association in order that these installations may be made throughout the country.

Regarding the receivers; they are of special design having very flexible output circuits so that they may be used with any number of reproducers or head phones and permitting individual control of volume. Thus they can be installed with outlets at each bedside.

## AVIATION SIGNALING

WHILE television has not reached the stage of commercial application as yet, the devices and principles of television are being used for more than one commercial application. A very promising one is for signaling from an airport to an airplane in flight, giving visual indications of various pertinent facts required by the pilot for flying and landing.

In the editorial last month Hugo Gernsback pointed out how television could be used to control a plane from the ground, giving views in six directions from the plane. Another scheme for visible signaling to a pilot in a plane was described recently in AMATEUR WIRELESS. The device consists of a radio transmitter having a modulation system for sending out audible signals on previously chosen frequencies (see Fig. 2A). The receiver in the plane consists of an amplifier and detector, the output of which is connected to a series of tuning fork resonators (Fig. 2B) which select the various audible signals sent by the transmitter and pass them on to a cathode ray tube which indicates on a calibrated dial any one of four or five pertinent facts.

It is suggested, in the original article which appeared in AMATEUR WIRELESS, that the usual compass scale could be made with a glass plate against which the fluorescent screen of the cathode ray tube would be placed. This compass scale would be equipped with the various predetermined indicators such as visibility, strength of wind, etc. as shown in Fig. 1, which would combine the two useful instruments on the already overcrowded dashboard.

By varying the strength of the modulated signals at the transmitter the indicator in the cathode ray tube could be made to move across the calibrated scale on the plane. While this device employs television devices, it will be noticed that no scanning or synchronizing is required. Thus it is not only an

Fig. 3  
An experimental circuit for using class B in the R.F. amplifier of a receiver. Tube V1 is a screen grid driver which operates the class B amplifier, V2

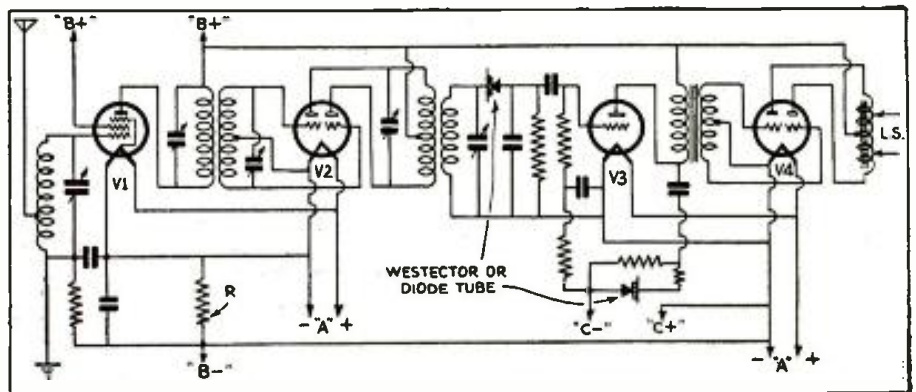

inexpensive device but is also rugged and simple in construction.

### CLASS B IN R. F. AMPLIFIERS

CLASS B amplifiers have found many uses in audio frequency circuits for radio receivers, power amplifiers, public address systems, etc. In England and other European countries advantage has been taken of the economy in "B" power consumption since the plate current in a class B amplifier drops down considerably when no signal is being received. This is especially true in battery sets of both the home and portable varieties where the "B" batteries are the most expensive item of upkeep.

In a recent issue of POPULAR WIRELESS a new system of using class B tubes and circuits for R.F. amplification made its appearance. An experimental circuit utilizing an R.F. pentode followed by a full-wave class B R.F. amplifier, a copper oxide diode rectifier and a class B audio system consisting of a driver and a full-wave class B power tube, is shown in Fig. 3. In this circuit the combined plate current for the two R.F. tubes, V1 and V2 flows through a resistor R. The voltage developed across R is applied to the control-grid of tube V1, thus providing a negative grid bias.

Obviously, when a station is tuned in, the plate current of the class B tube will rise and in turn the voltage across R will increase. This will cause a higher negative bias to be applied to tube V1. This will be recognized as providing the main essential of a simple A.V.C. system.

This experimental circuit should provide much useful material for those who enjoy experimenting with new circuits and ideas. The copper oxide detector can be replaced by any diode tube and it is quite possible to combine the diode rectifier with the driver tube of the A. F. amplifier. There is no reason why the class B R.F. stage should not be the I.F. amplifier of a superheterodyne.

While this circuit is an experimental idea, it should be ideal for use in portable sets where "B" current is important.

### AN EASILY MADE FULL VISION DIAL

A DESCRIPTION appeared recently in AMATEUR WIRELESS for converting an ordinary friction drive tuning dial to have the features of a modern full vision scale. Since there are many of these dials in use in American receivers the details should be of interest.

A glance at the illustration, Fig. 4, will show the idea. Briefly the device consists of a translucent celluloid window cut in the front panel upon which are inscribed the call letters and positions at which stations are received. The usual disc containing the dial numbers is removed and in the place of the scale, a pointer is mounted.

This pointer may be attached directly to the condenser shaft or to the lower half of the friction disc so that it will move over one half a circle when the condenser is turned from maximum to minimum.

The translucent celluloid screen can be made from any piece of sheet celluloid which is sandpapered to roughen the surface. Narrow picture frame molding can be used to make a border for the celluloid screen. It will be noted that the sample dial in the illustration contains the names of stations rather than call letters. This is common practice in Europe where many stations never mention their official call letters during their broadcasting hours. In this country however the task of calibrating the dial will be simplified since all of our stations are identified by their calls.

### A PHONOGRAPH ATTACHMENT

A NUMBER of devices are available in Europe for utilizing the audio amplifier in a radio receiver for amplifying phonograph records. Some of these devices are in the form of tables upon which the radio set may be mounted, while others take the form of a small external cabinet which is used in conjunction with either consoles or table model sets.

In a recent issue of RADIO WELT magazine, an Austrian publication, a device of this type was shown. It consists of a

(Continued on page 233)



Fig. 8  
The front panel of this phonograph unit pulls out the turn-table shelf.

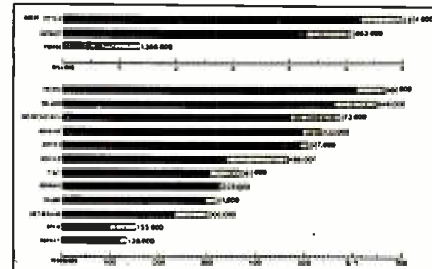

Fig. 5  
A comparison of the number of licensed radio sets in the countries of Europe.

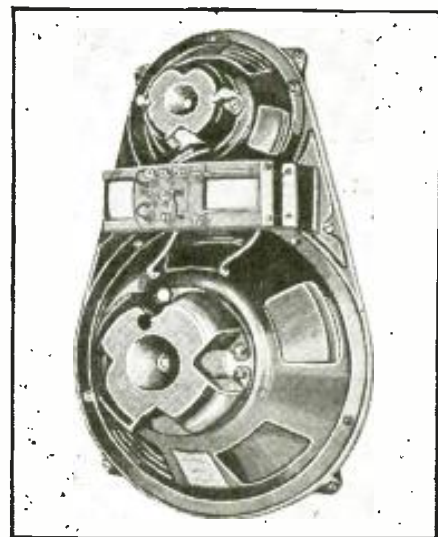

Fig. C, above  
The appearance of the dual speaker unit with its single output transformer

Fig. 4  
The full vision dial converted from an old friction drive vernier dial.

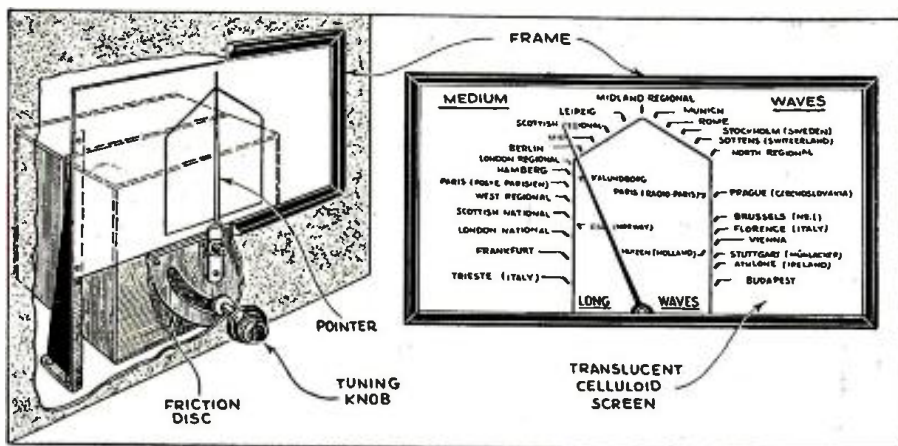
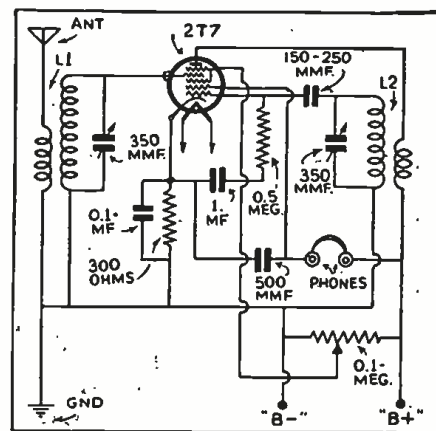

Fig. 6, below  
The Italian single tube reflex.



# THE ALL-WAVE "1/2-DOUBLET" ANTENNA

The author describes a new antenna system adaptable to the 1/2-wave Hertz (doublet) or 1/4-wave Marconi (inverted-L) aerials.

GLENN H. BROWNING\*

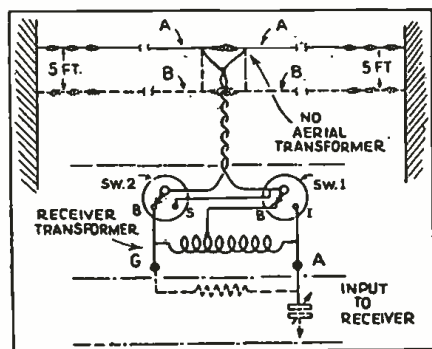
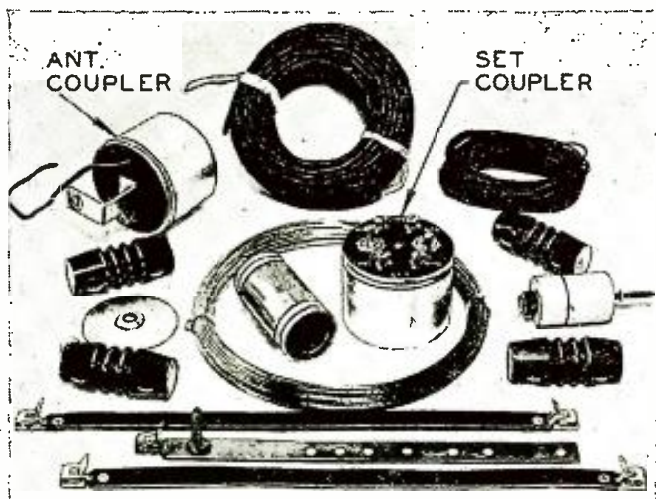

Fig. 2 Multiple- (dotted), and 1/2-doublet set-up.

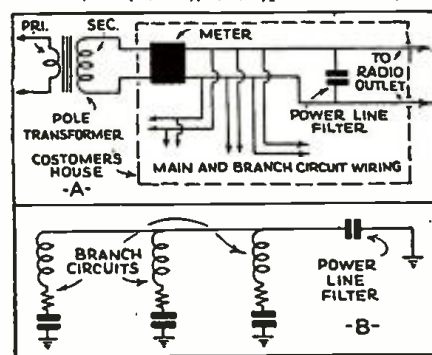
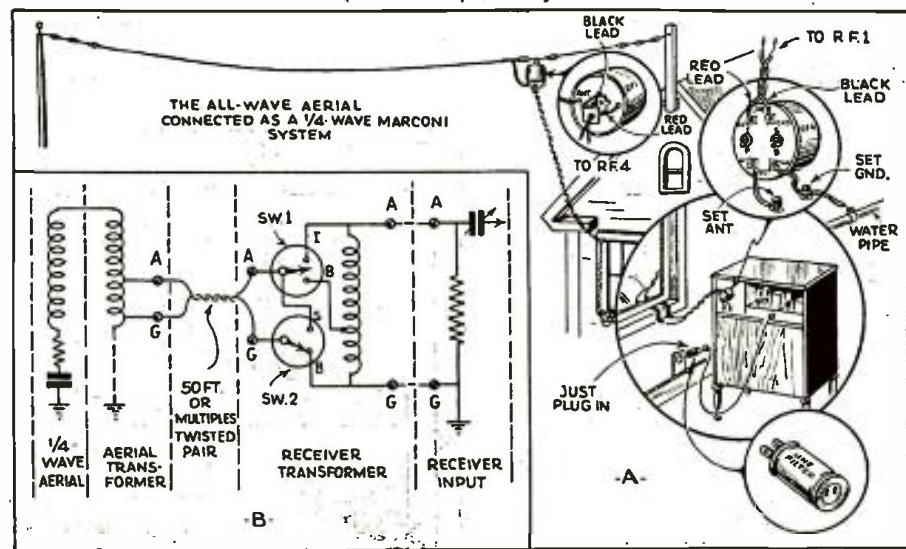

Fig. 3, above Actual (A), and equivalent (B) filter.

Fig. 1, below At A, installation of the new all-wave system, connected as a 1/4-wave Marconi antenna; at B, equivalent analytical diagram.



SEVERAL unique features will be found in one of the latest all-wave antenna systems that has recently been announced and made available to the radio trade. This all-wave aerial is essentially designed for use in the average home where ideal antenna installations cannot be made because of space limitations, character of the structure, and other local unfavorable conditions are concerned. (Previous types have been discussed in the article, "Important Facts About All-Wave Antennas," in the July and August, 1934, issues of RADIO-CRAFT.—Editor)

Expense of installation is kept at a minimum inasmuch as present flat-top aerials may even be used with this system if they were originally installed ruggedly and correctly.

## A 1/4-Wave Marconi Antenna

The installation of the all-wave aerial as a 1/4-wave Marconi antenna system is shown in Fig. 1A. In this system the ground is an integral part of the aerial or open-oscillatory circuit. The system consists of an average-length flat-top aerial (approximately 75 ft. for best results) connected to the

aerial transformer which is suspended from the guy wire supporting the aerial; twisted-pair transmission line transfers the signal to the receiver transformer which is designed to permit different coil arrangements to be secured, by means of switches, in order to properly match the transmission line to the input of the receiver at the various desired frequencies. The receiver in this case is grounded.

Figure 1B shows the equivalent-circuit diagram of the all-wave aerial connected as a 1/4-wave Marconi system. Note the method of coupling from the aerial circuit to the receiver input circuit. Coil taps were so chosen that the system operates best with transmission lines of 50 ft. or multiples thereof in length.

Note the switches Sw. 1 and Sw. 2 of the receiver transformer; the following positions of Sw. 1 and Sw. 2, respectively, indicate the bands to which they will tune: B-B standard broadcast frequencies from 500 to 1,500 kc.; I-B intermediate frequencies from 1,500 to 6,000 kc.; I-S highest frequencies, ranging from 6,000 to 15,000 kc.

On position I-S the transmission line is short-circuited. In this position the entire system functions mainly as a straight pick-up aerial for the high-frequency signals. This is essential in order to get true all-wave performance from one antenna kit. The use of the ground on the radio set adds great stability to the operation of the receiver.

## A 1/2-Wave Hertz Antenna

This same system may readily be adapted for operation as a Hertz or 1/2-wave antenna system. In this connection the doublet type of Hertz aerial is extremely popular for it is convenient and inexpensive. Here the installation is made as shown in Fig. 2. It is important that the aerial flat-top be as high above the ground as possible.

Table I indicates the length of the flat-top sections for different popular short-wave bands.

—(Continued on page 239)

# SUPER-SHORT RADIO WAVES

A new tube—the "end plate" Magnetron—that generates "quasi-optical" or radio waves only about 4 inches long has been developed. Like light, these super-short radio waves may be reflected, refracted and absorbed. The new tube has the record output of about 2.5 watts, its diminutive radiations being far shorter than the 200 inch or 5 meter wavelength utilized by "ultra short wave" radio stations.

I. WOLF,\*

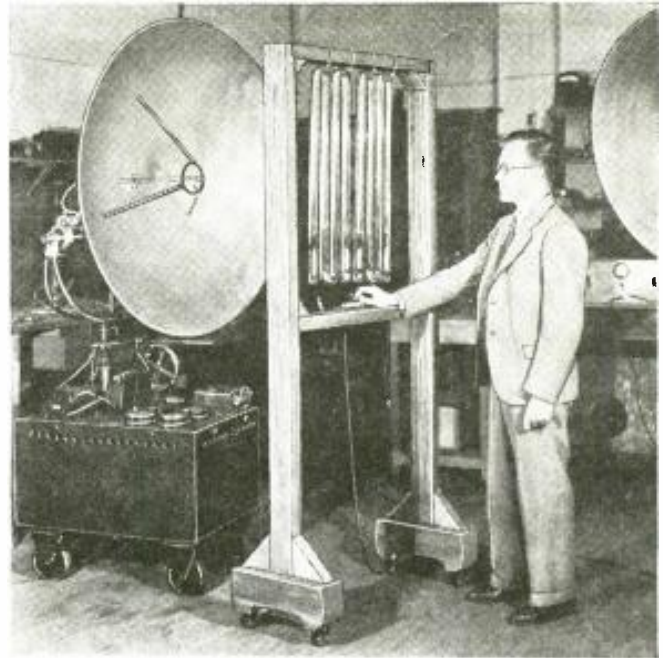

**S**UPER-SHORT radio waves only about 4 inches (10 centimeters) long, and of high power, were recently produced, and their effects demonstrated before a meeting of the Institute of Radio Engineers held at Benjamin Franklin Hotel, in Philadelphia, Pa. Radically new means of controlling the modulation and intensity of these "quasi-optical" or light-region wavelengths were described.

## Centimeter Wavelength

Of special interest is the fact that the wavelength used in these experiments is only 1/5 the length of the waves used by Guglielmo Marconi in his experiments (in Italy) recently mentioned in the press. Some idea of the size of these "centimeter" waves may be had by comparing them with a standard, 300 meter (1,000 kilocycles) broadcast station, which has a frequency of 1 million cycles per second, as against 3 billion cycles per second

\* Eng. Div., R.C.A.-Victor Co., Inc.

for a 10 centimeter wave. The comparison is also shown in Table I.

TABLE I

METERS	CYCLES
300	1,000,000
200	1,500,000
100	3,000,000
10	30,000,000
1	300,000,000
*0.1	3,000,000,000

\*0.1-meter equals 10 centimeters.

Since the characteristics of "centimeter" waves, as distinguished from the "meter" waves used in present-day radio operation, are similar to ordinary beams of light, they have an obvious advantage in that they may be directed like a searchlight to the receiving point; experiments show that these waves may be reflected from metal surfaces just like ordinary light. Consequently, just as in pointing a searchlight, the transmitter of this super-short radio wave system utilizes

a parabolic metal reflector which concentrates the energy of the centimeter waves in the desired narrow path directly to the receiving point, where a similar reflector is used to pick up the transmitted energy and concentrate it on the receiver. The transmitter is shown in the heading illustration and also in Fig. A; the receiver is shown in Fig. B. They are also shown in schematic form at A and B, respectively, in Fig. 1.

(Continued on page 232)

Fig. 3  
The "end-plate" magnetron and its circuit.

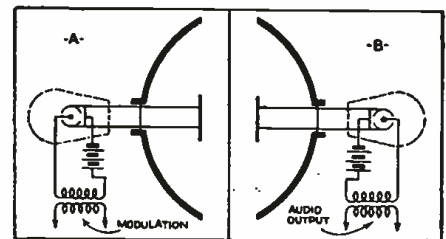

Fig. 1, above  
The magnetron as, A, oscillator and, B, detector.

Fig. A, below  
The "4 inch" transmitter and modulating screen.

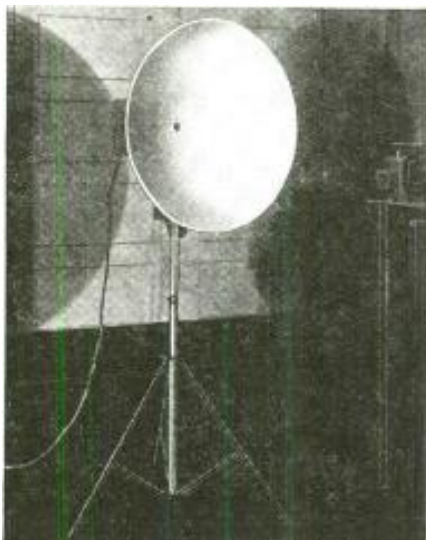
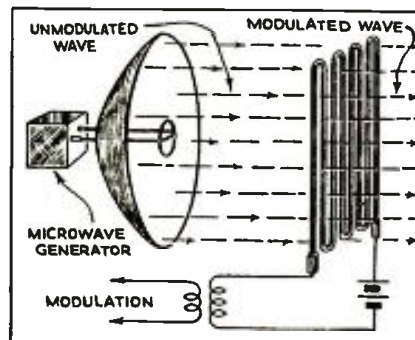

Fig. B, left

The receiver of the 4 inch radio waves. At the focus of the reflector is placed a dipole or doublet antenna, connected to a detector.

Fig. 2, below

The method of modulating the ionized electron screen, or "man-made Heaviside layer."



# USES OF A NEON-TUBE CONDENSER ANALYZER

There are few Service Men that are equipped with an accurate condenser analyzer. The unit described here will save radio men considerable work and headaches in locating receiver defects caused by condensers. Leakage, and the effective resistance of all types of condensers are indicated by a neon tube.

C. W. PALMER

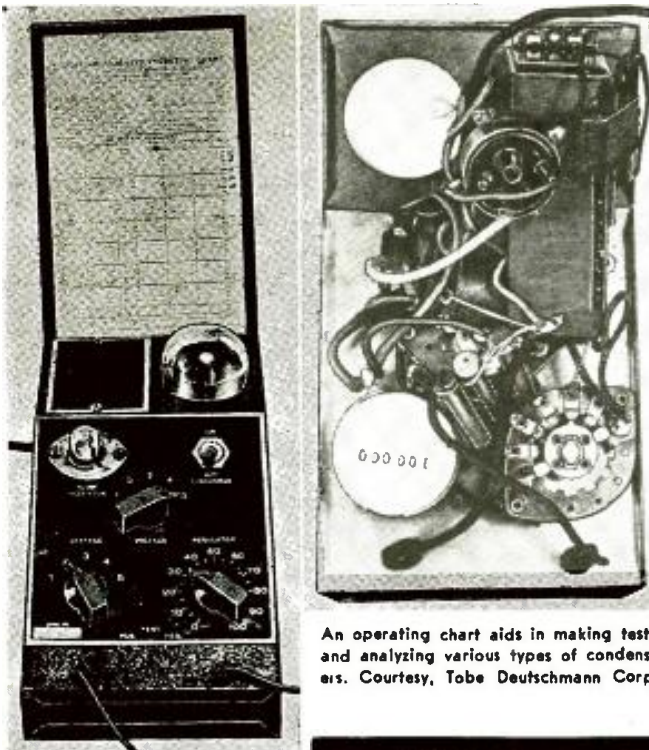

An operating chart aids in making tests and analyzing various types of condensers. Courtesy, Tobe Deutschmann Corp.

**A** NEW circuit has recently been put to use which seemingly offers many practical suggestions to the radio Service Man for general application around a radio service laboratory.

The circuit shown in Fig. 1 is the schematic diagram of a new condenser analyzer and is applied for testing of all types of condensers found in general radio service work.

As can be seen from a study of the diagram, the 110 V. input is stepped up by means of a high voltage transformer and the current is rectified by the use of an 01A tube. In this connection the grid and plate of the tube are connected together at the socket so that the tube performs actually as a half-wave rectifier. The output voltage appearing across AB is controlled by adjusting an arm which contacts taps on the high voltage transformer. The maximum output voltage available is in the neighborhood of 700 volts D.C. The regulator control, a wire-wound rheostat, permits small intermediate voltage changes as well as limiting the current passing through the device on

a short circuit condition.

A special neon tube having a low striking voltage is connected in the negative return. In parallel with the neon tube are connected three resistors of various values and a flash control condenser C1. The condenser or each resistor may be connected in the circuit by means of the leakage control arm.

For testing condensers of the solid dielectric type such as paper, mica, or oil, the leakage control is set to position No. 2 and the other controls set to give the highest voltage output. The condenser to be tested is connected across the output of the device marked "test." Connected in this manner the circuit is actually set up as a relaxation oscillator, in which actually the effective D.C. resistance of the condenser under test will be indicated.

When the condenser to be tested, CX, is applied across the test terminals, if the condenser is good, a charging current will immediately flow through the condenser CX, charging up condenser C1 to a potential sufficiently high to cause the neon glow tube to ignite. As soon as the condenser CX has become

charged, the charging current will stop flowing, the potential across C1 will disappear and the neon tube will become extinguished. The effective resistance of CX, however, will cause a minute current to continue to flow through the test circuit. Gradually C1 will be charged to a voltage sufficiently great to again cause the neon tube to ignite. When this occurs, the voltage across C1 will drop until again the neon becomes extinguished. Current, however, continuing to flow through the effective resistance of CX will continue to charge C1 to the striking voltage of the neon tube. The lower the effective resistance of the condenser CX, the greater will be the leakage current flowing through the test circuit, and the sooner will C1 become charged to the striking voltage of the neon tube.

A newly made condenser having high effective resistance will permit such an extremely minute current to flow through the test circuit, that the flashes of the neon tube will be infrequent, sometimes as much as five or ten minutes apart.

Old or poor condensers having a low D.C. resistance will cause the period of oscillation and consequently the flashing rate of the neon tube to be as fast as one flash a second and faster. A chart accompanying the instrument indicates allowable rates of flashes. Faster rates of flashes than these indicate very poor condensers which should be replaced or should not be used.

The period of oscillation of the circuit is dependent upon several factors: first the voltage appearing across points AB, the effective resistance of the condenser under test, the capacity of the flash control condenser C1, and the characteristics of the neon

(Continued on page 238)

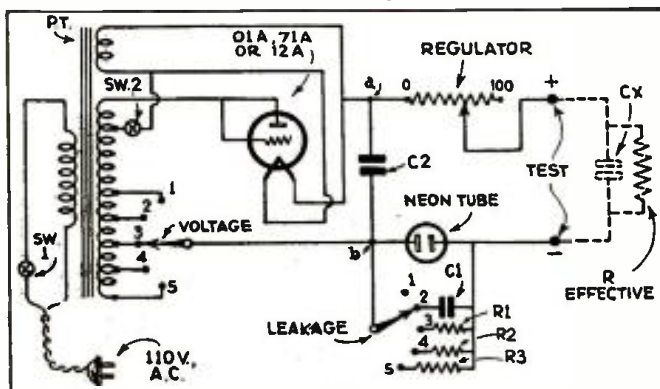

Fig. 1  
Wiring diagram of the condenser analyzer. The vacuum tube is employed as a half-wave rectifier, and the special neon tube has a low "striking" voltage for sensitivity.



# AN INEXPENSIVE HIGH-GAIN AMPLIFIER

Considering that this amplifier employs type 45 tubes in the output, the power will amaze the constructor. The original is now being employed in an installation that ordinarily required a 20 watt amplifier. And, surprisingly, the quality is very good.

H. V. BADINSKI & JEROME NEWMAN

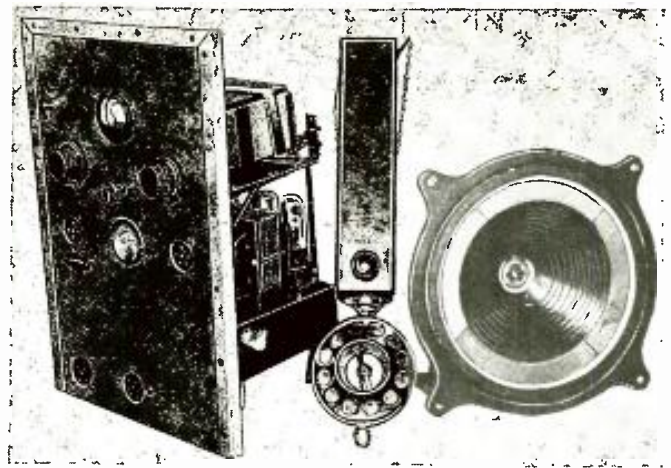

Fig. A. The amplifier and power supply are separated.

**B**EING in need of a powerful amplifier for P.A. work, we went looking for information and found practically nothing. Therefore, we decided to sit down and figure out just what we desired and then experimented until it was perfected.

The requisites of the public address system were:

1. Power—From 15 to 20 W. output.
2. Quality—Distortionless, or nearly so.
3. Inexpensive—Initial cost not too high.
4. Portability—Not too bulky or heavy to be transported in an automobile.

With these conditions in mind we haunted radio supply stores for several days, and finally emerged with the fact that a special input transformer for class A prime, for a 45 tube driving two 45's, was available.

As all radio men know, 45's are praised for their clarity and freedom from distortion. But their power output has been believed to be limited to 3 W. in push-pull. Now to do the impossible! As many watts (as possible) of clear, undistorted power from 3-45's, a 57, a 56, and a 5Z3!

Tube data sheets were studied and taken into consideration, but in the final analysis it is actually trying different values of resistance and capac-

ity that counts. The first attempt was made to feed the output of a 57 into the driver 45 and then into 45's in class A prime. This design gave approximately 8 W., which was not enough for the purpose.

After some testing it was discovered that the output 45's were not being loaded. In fact, one 45 could be removed with no decrease in volume! Next we found that the driver 45 was not being loaded. Then, we stopped and did some more figuring.

The best high impedance phonograph pickup made will not deliver more than one-half volt. Most good pickups will deliver about 1/4-volt. A 57 tube used as an A.F. amplifier has an amplification factor of about 100.  $100 \times \frac{1}{4} = 25$  V. input to the driver 45. A 45 tube takes an input voltage of from 45 to 50 V., so we must increase the input. A 56 tube has an amplification factor of 13 and used in conjunction with a good 2 to 1 transformer we get an amplification of 2600 in our first two tubes.  $100 \times 13 \times 2 = 2600$ . This is enough to load the driver 45 even if the input to the 57 is only 18 millivolts, (.018-V.). We include the 56 and A.F. transformer and try the amplifier again. Now we have something!

In a hall 150 ft. long by 40 ft. wide, the wooden floor vibrated before the amplifier was turned on full. And yet,

even at full power the tone was clear and sweet, the only distortion being a slight needle scratch.

The class A prime amplifier was then compared in this hall with a straight push-pull amplifier using 2-50's, 2-81's, a 56 and a 24, with a separate A.C. auditorium dynamic speaker. The voltage on the plates of the 50's was over 550 V. On the 45's, 275 V. The speaker used with the new amplifier was an RCA photophone pot (or field), with an RCA 106 frame and cone, 1000 ohm field used as choke coil. At slightly more than half power the new amplifier drowned out the 250 amplifier at full power. We were satisfied we had built the best possible amplifier at the lowest possible cost.

In building this amplifier it will be noted that a separate "C" battery is used. Fixed bias is necessary with class A prime and the easiest and simplest way to get it is with batteries. For those who desire it, another method of obtaining fixed bias is shown using an 82 tube and special filter circuit. In this connection it should be noted that the 82 is worked in reverse as a half-wave rectifier. The two plates tied together are about 300 V. *negative from ground*. If batteries are used, try voltages ranging from 45 to 70 V. as different tubes will need more or less voltage. Small

(Continued on page 237)

Fig. 1, right. Wiring diagram of the "C" bias supply and input connections.

Fig. 2, below. Diagram of the high-gain amplifier; employs three driver stages.

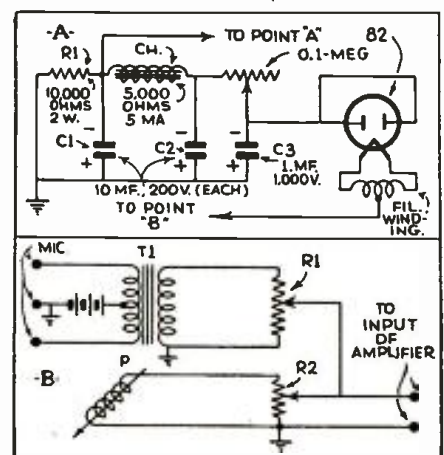
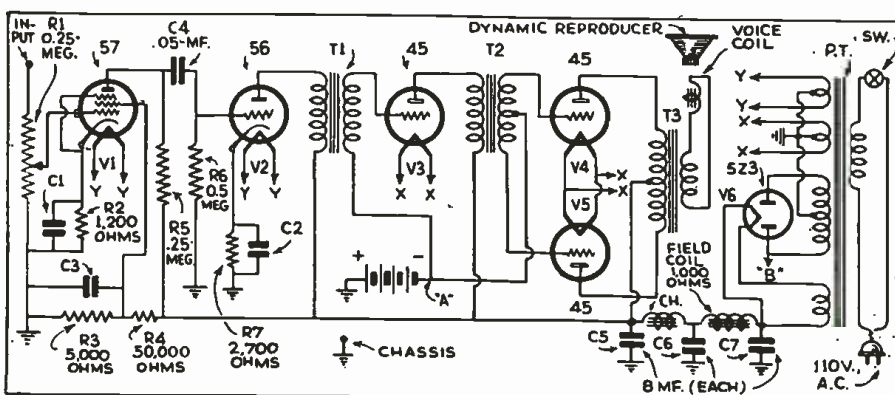

# AN ULTRA-SMALL SET ANALYZER

A new instrument for set analysis which is really portable. It combines many features that are usually found only in large instruments for shop use. This instrument is unusually flexible and will not become obsolete.

ROGAN SHANNON

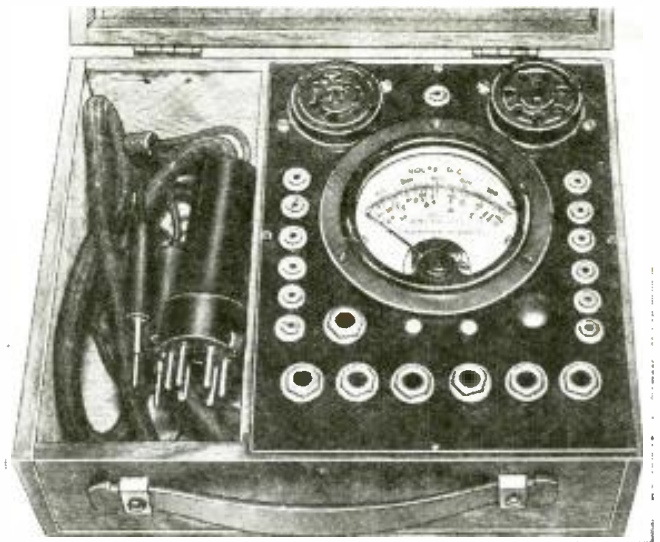

**M**ANY excellent designs for set testing equipment have been offered the Service Man, so many, in fact, that it is sometimes difficult for the Service Man to decide which is the most suitable instrument for his particular use. Some of them, in order to economize or to simplify, sacrifice some testing feature that would be of real use to the man who must use them. Others are so complicated that their switching systems are better suited to the large shop panel than to portable use.

After looking over a great many designs this instrument was built, trying to use some of the best features of some of the others. It was built with certain definite requirements in mind. The first, of course, was that it should be flexible enough to meet the ordinary service job. The second was that it should be built of good quality parts.

In order to fill the flexibility requirement, it was decided that the following features should be incorporated:

1. Enough D.C. voltage ranges to cover the voltages commonly found. Proper multipliers being handy, these ranges were made 10, 100, and 600 volts.
2. Two D.C. ranges, 10 and 100 milliamperes.

3. Two A.C. voltage ranges, 15 and 150 volts.
4. An ohmmeter with a range of 0-100,000 ohms.
5. Arrangement for use as an output meter.
6. A switching system that would allow a battery bias, either positive or negative, to be placed on any of the tube elements while reading the plate current, so that a mutual conductance test could be made with the set's power.
7. Ability to read the voltage, either A.C. or D.C., of any element of the tube with any other element or the set chassis as the reference point.
8. Ability to read current in any of the tube element leads except the filament leads.
9. Ability to make a complete point-to-point resistance analysis from the instrument panel by plugging into the tube socket.

All of these tests, of course, would have to be made on any of the many types of tubes now in general use, which calls for a switching system to cover up to seven prongs and a cap, or eight elements in all. Provision for tests on future types of tubes can be easily arranged by means of adapters.

(Continued on page 251)

At right is shown the circuit of the analyzer, while below appears the interior of the instrument, showing the layout of parts.

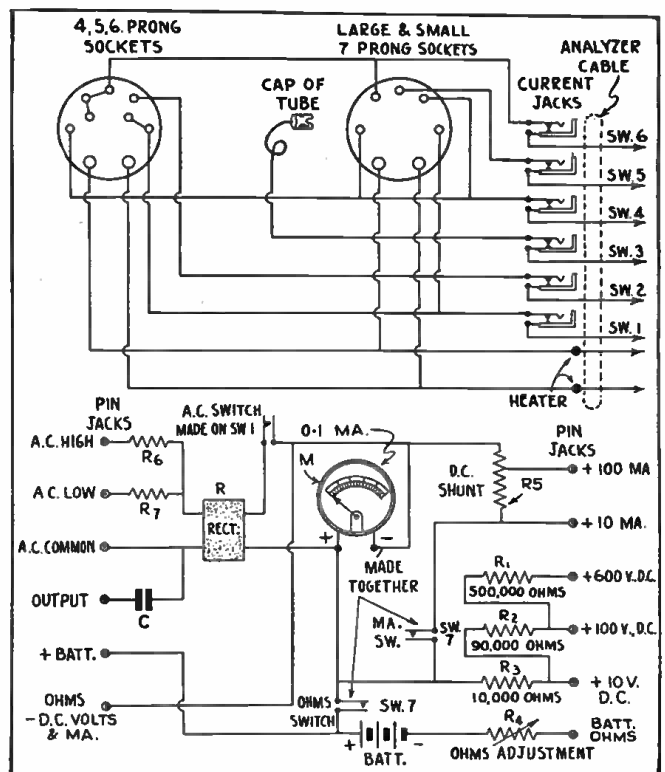
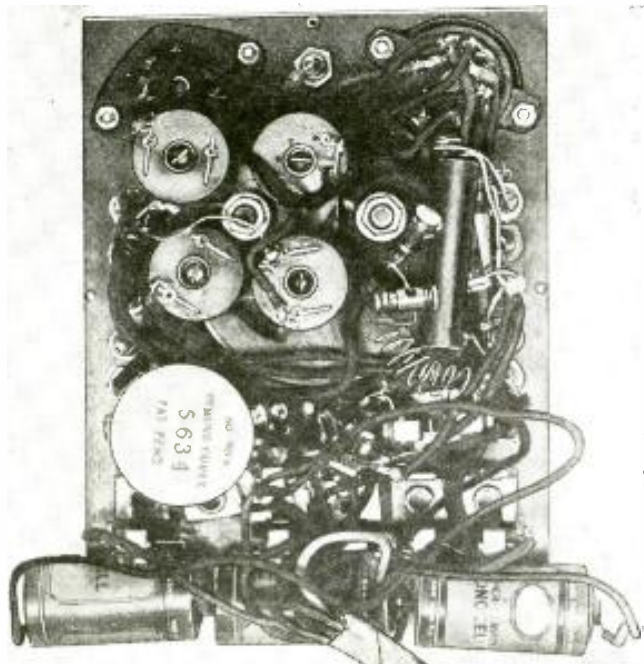

# HOW TO USE THE NEW TUBES

A great many constructors are confused on the correct application of some of the latest tubes. Therefore, we present in this article data on the differences and similarities between the 2.5 and 6.3 volt tubes.

WM. M. PERKINS\*

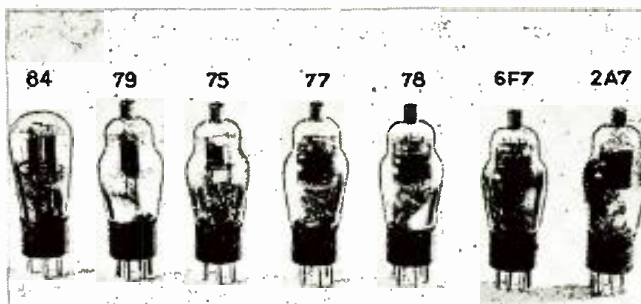

Fig. A. The above are some of the most popular tube types.

**T**HE VARIOUS tubes in these two groups generally referred to as "2.5 V." and "6.3 V." may be compared one with the other and with each other in additional, well-defined groups.

## The Triode Group

Starting with the small triode tubes, one finds in the 2.5 V. line the 27 and the 56. The corresponding types in the 6.3 V. line are the 37 and 76. While the 56 and the 76 have identical electrical characteristics, excepting for the heater voltage and current, the 27 and 37 differ slightly. The 37 has a smaller cathode, using less watts than the 27, and has somewhat reduced mutual conductance and plate current, but for all practical design purposes may be considered as essentially the same.

## Diode-Triodes

Also, in this group of small triodes, one might add the several tubes which have, in addition to the triode, a pair of diodes. In the 2.5 V. line are types 55 and 2A6. The 6.3 V. line has types 85 and 75 corresponding respectively to the 55 and 2A6. Type 55 has an amplification constant of 8.3, while that of the 2A6 is 100, thus accounting for the differences in voltages and currents used to get the same mutual conductance of 1,100. Where power is not needed, but high gain and high output voltage are desired, the 2A6 is usually used.

\* Eng. Div., Nat'l. Union Radio Corp.

Fig. B

The constructor must choose his tubes from over 100 different types.



## Non-Variable-Mu Tetrodes and Pentodes

The sharp cut-off (non-variable-mu) tetrodes and pentodes which find service mainly as first- and second-detectors in superheterodynes may be put in one group. In the 2.5 V. line are the 24 and 57 tubes, with the corresponding tubes in the 6.3 V. line being the 36, 6C6 and 77. Types 36 and 24 are tetrodes, whereas 57, 77 and 6C6 are pentodes. The 36 has a smaller cathode than the 24, but with characteristics which very nearly coincide excepting for less watts in consumption in the heater. Type 77, while having a structure quite different from the 6C6, has essentially the same electrical characteristics. The 77 has a shield around the plate, while the 6C6 has a shield above the plate. The use of this outer shield makes the 77 require less shielding in a radio receiver, while, on the other hand, it increases the output capacity which may prove a disadvantage in certain high-frequency circuits.

## Variable-Mu Tetrodes and Pentodes

Tubes recommended for service in the R.F. stage, I.F. stage and sometimes first-detector, form a group of pentodes and tetrodes which has a remote cut-off (variable-mu) control grid characteristic, thus enabling one to control gain without introducing distortion or cross-talk. Here again one finds that the 2.5 V. line has fewer types than the 6.3 V. line. In the former group are found only the 35 and the 58. The 35 is essentially a type 24 having a remote cut-off type grid; the 58 bearing the same relation to the 57.

Corresponding to these tubes in the 6.3 V. line are the 39, 44, 6D6 and 78 types. The 39 has less remote cut-off than the 35, having been designed for use in automobile radio sets where the input signals never reach the value encountered in home sets using large aeri- als. Type 78 has characteristics lying about halfway between the 39 and the 6D6, while the 44 is so similar to the 39 that a tube is now made which replaces either the 39 or the 44 and is designated type 39/44.

All of these tubes, with the exception of the 35, are pentodes, some of them having the suppressor-grid brought out on a separate pin. Another structural difference is that types 58

and 6D6 have a shield above the plate, while types 39/44 and 78 have a shield around the plate.

## Special-Purpose Tubes

There are several tubes which must be classified as special tubes, or combination tubes—namely, the 2A7 and 2B7 and the corresponding tubes in the 6.3 V. line, namely, 6A7 and 6B7. The 6A7 is a tube for converter use in which certain of its elements constitute the oscillator source. In this tube, the mixing of the oscillator with the input signal is effected solely by virtue of its electron stream and requires no external coupling.

The 6F7 is designed primarily for the same purpose as the 6A7, but must be used in circuits which couple together its triode oscillator with its pentode mixer section. Due to the complete separation of the pentode section and triode section, this tube can be used in other circuits, and so, in that way, has a wider field than the 6A7.

Types 2B7 and 6B7 are 2.5 V. and 6.3 V. tubes, respectively, with a pentode section and a pair of diodes. The pentode section is neither a remote cut-off tube, nor a sharp cut-off tube, but lies between. Its use is mainly confined to diode detection and high-gain pentode A.F. amplification, although, in other uses, such as pentode I.F. amplifier and diode detection, it is sometimes a convenience.

(Continued on page 250)

Fig. C

A—the midget, B—the auto-radio, and C—the standard receiver—all employ tubes especially designed for each.

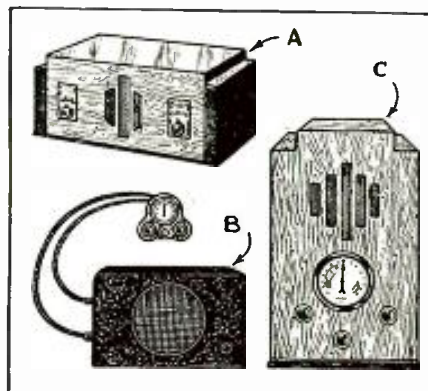

# A 5 TUBE ALL-WAVE SET

The present trend in receiver design is featuring all-wave reception. With this in mind, we present to the constructor a remarkably efficient and sensitive receiver that covers all short-wave and broadcast bands. It has received all European, South American and Australian stations with unusual volume and clarity.

H. G. CISIN

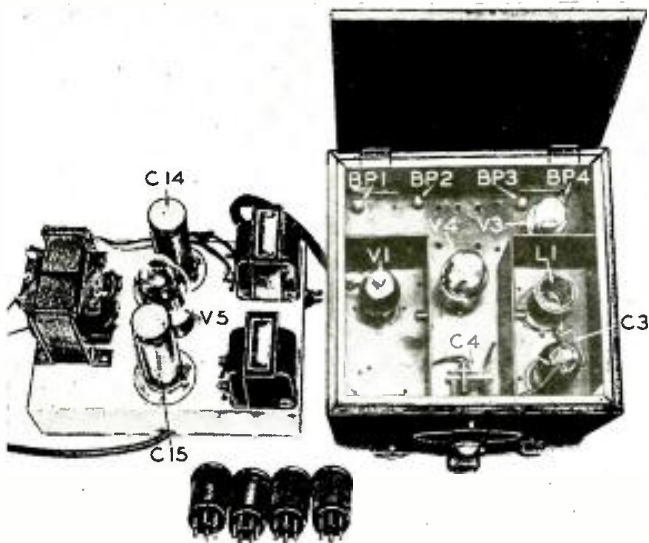

**D**ESPITE the fact that this all wave five tube set employs a simple circuit, this receiver is highly suitable for use as the constant experimenter's or Service Man's "personal" all-wave set. It is also an ideal receiver with which to meet the demand for a deluxe model custom-built set, since it has excellent tone quality, ease of tuning and unquestioned ability to reach out and bring in foreign reception consistently.

Soon after the final model was completed, it was tested at the home of Mr. O. B. Kusterman, in Brooklyn, N. Y., and VK3ME, Melbourne, Australia, 9,000 miles away, came in with full loud speaker volume. Verification of this reception has been received. Foreign reception on this set has been continuously and consistently good, right up to the present moment. For example, at 10 P.M. on July 28, 1934, the writer listened to DJC, Germany, operating on 49.83 meters. A talk was being given on the gratification expressed by the British Press over the appointment of Von Papen as ambassador to Austria. At 6:20 A.M. on July 29th, the next day, the writer listened to VK2ME, Melbourne, Australia, broadcasting on 31.28 meters. Several phonograph records were played and then there was a description of the scenic beauties of Queensland. Full, undistorted loud speaker volume

was attained in both cases, with noticeable absence of static and fading.

These are merely typical instances of the capabilities of this set. Two six-prong plug-in coils are used to cover the broadcast band, while four similar type coils are needed to cover the short wave band from 15 to 200 meters. Incidentally, this set lends itself to the use of the new-type band-spread coils. When the broadcast coils are used, the set is converted to a standard broadcast receiver, notable for its selectivity, sensitivity and particularly excellent tone quality. All the short wave coils (when used at the proper time) are very much alive, and there is a never-ending procession of foreign stations, aeroplane calls, C.W., amateur conversations, etc., as the single control dial is tuned.

The receiver employs an untuned r.f. stage, using a 58 tube and a regenerative detector using a 57 tube. The first audio stage employs a 56 type tube resistance coupled to the detector. A 2A5 tube is used in the output stage with resistance coupling also employed between the two audio stages. The 2A5, with its 3 watt rating, makes the set powerful enough to meet all requirements.

Tuning is accomplished by means of a midget condenser, shunted across the secondary of the plug-in coil. Despite remarkable selectivity, the ease with

which foreign and distant stations can be tuned in, constitutes one of the amazing features of this set. Volume is controlled by means of a variable resistance in the cathode circuit of the 58 tube, while regeneration is controlled very smoothly through the use of a potentiometer in the screen circuit of the 57 tube. The correct maximum screen voltage is obtained by means of a voltage divider system.

The power supply for the receiver is built up as a separate unit, to avoid all possibilities of trouble from A.C. hum. The power pack is assembled on a small metal chassis and consists of a power supply transformer, an 80 type rectifier, filter chokes and electrolytic condensers. A 30 henry choke is used in addition to the speaker field. This more than adequate filtering gives humless operation, even when headphones are used (with coupling transformer) in the output of the 2A5.

The set is built into a compact metal cabinet, with the r.f. and detector stages in separately shielded compartments. Because of the simplicity of the circuit, it is quite easy to build.

## Construction Details

The five sockets are fastened to the metal chassis as shown in the top view illustration, also the four binding posts.

(Continued on page 245)

Fig. A. left. Sub-chassis view and layout of parts. All numbers are explained in the text.

Fig. 1. below. Diagram of receiver. Power supply is built in separate unit.



# CONVERTING OLD SETS

In last month's RADIO-CRAFT we imparted data on converting electric sets, for Service Men, to bring them up-to-date. In this chapter on "conversion" we deal essentially with methods for making old sets over into "rural" or battery receivers.

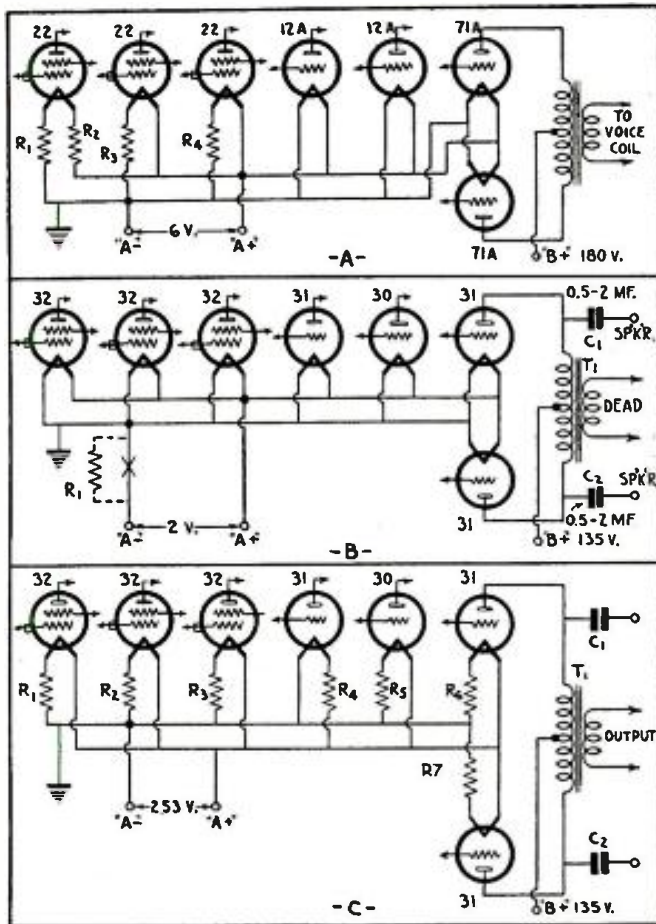

Fig. 1  
The 2V. operation of A.K.67 and 67C.

## 2 V. OPERATION OF A.K. 67, 67C GORDON E. LOCKERD

ONE of the most satisfactory changes to 2 V. operation, both from the Service Man's standpoint and that of customer's satisfaction, was made by the writer on the Atwater Kent models 67 and 67C receivers. These sets use screen-grid tubes, 2 type 12A tubes as detector and first A.F., and a pair of 71As in push-pull as output. The set uses a 6 V. dynamic speaker the field of which draws approximately  $\frac{3}{4}$ -A. Since the tubes alone draw nearly  $1\frac{1}{2}$  A., the total "A" battery drain is in the neighborhood of  $2\frac{1}{4}$  A. This excessive "A" current makes constant battery charging a source of worry and trouble to the owner of one of these sets.

By substituting a good magnetic speaker or a permanent magnet dynamic for the one in the set, and changing the tubes to the corresponding types of 2 V. tubes, the "A" battery drain can be lowered to .63-A. With a 290 A.H. 2 V. wet cell this will give the customer about 450 hours of uninterrupted service compared to about 40 hours that he was receiving. These tubes, in addition, will require much less plate current with a corresponding increase in "B" battery life.

I have made several different types of changes in this set, all of which I will explain. The process is very simple if a 2 V. source of "A" current is to be used, but a little more complicated if the air cell type of battery is to be installed.

In Fig. 1A, is a sketch of the filament circuit as it is factory wired. Only this circuit is shown, as it is the only one in which changes are made, except for those in the output circuit. (Reference to your service manual will give you the entire schematic if it is desired.)

Unsolder all of the filament resistors which are mounted directly on the underside of the type 22 sockets, and entirely remove the resistors. Solder the filament leads, which were originally attached to the resistors, to their respective filament contacts on the sockets.

This is the only change necessary in the filament circuit; the new arrangement is shown in Fig. 1B, together with the suggested change for the output circuit. If a permanent magnet dynamic speaker is to be used one can be secured to match the present output transformer (which I believe has an impedance of 6 ohms to match a voice coil). In most cases, however, it is desirable to use a good magnetic speaker, in which case a new output transformer must be secured or the system shown in Fig. 1B adapted. This makes use of the primary of the present transformer as an output choke and capacitive coupling to the speaker is used. This really gives excellent results and leaves nothing to be desired. However, if the old speaker is being taken in on the job it is good policy to keep the transformer in the set with the speaker as it is especially designed for it.

Actual results after this change were found to be equal in every respect to the set's former performance. The 31 type tube was chosen in preference to the 30 as the detector because of this set's tendency to microphonic howl.

For change to air cell operation, everything in the foregoing matter holds true except that the correct resistor must be inserted to gain the desired voltage drop. This may be done in 2 ways; by inserting individual resistors as shown in Fig. 1C, or by simply inserting a single resistor at the point marked x in Fig. 2. The former method is much to be preferred as will be explained later.

Since the initial voltage of the air cell battery is 2.53 V. and the upper safe limit of operation for these tubes is 2.2 V., we must have a voltage drop of .33 V. The current required for the entire set is .63-A. So, by applying Ohm's Law we find that a resistor of .524-ohm is required to drop the voltage to 2.2 where a single resistor is used. A  $\frac{1}{2}$ -ohm unit may be used plus the resistance of the leads (for the additional .024-ohm). This single resistor is the simplest way of doing the job, but has several disadvantages, such as the extreme critical value of the single limiting resistor at this low resistance. It is also evident that if one or more of the tubes are removed as is sometimes done, the voltage will rise correspondingly. All "A" battery leads must be kept short and connections and contacts clean so that no appreciable external resistance may be added, as we can readily see that an extra  $\frac{1}{2}$ -ohm resistance would cut the voltage far below normal.

It is much more desirable to use individual resistors for each tube. This also has the advantage of allowing the voltage drop across the resistors to the R.F. tubes to be used as a slight negative grid bias by attaching the grid return to the low-potential side of the resistor as shown in Fig. 1C. Another advantage is that the resistors are all of a higher value, consequently they are not so critical to a small variation from the specified value. For example, suppose the 5.5 ohm resistor in the type 30 filament was .1-ohm below rating or 5.4 ohms, the actual applied voltage to the type 30 tube would then be 2.206 V. or an increase of only .006-V. Now suppose that the single resistor of .524-ohm should be lowered .1-ohm or to .424-ohm, the

(Continued on page 243)

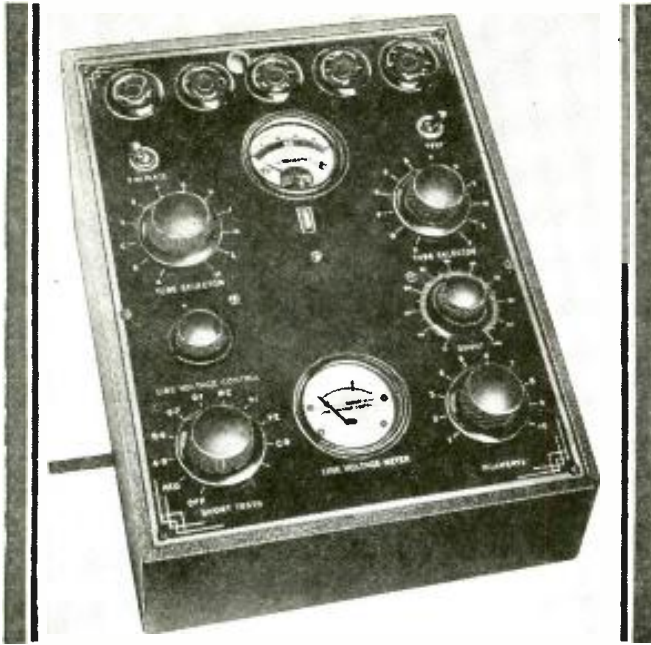

# A COMPACT TUBE TESTER

The tube tester described below is complete in every detail. As an aid to the Service Man it is invaluable, especially when it is considered that most receiver troubles are many times due to defective tubes. Much time can be saved by using this instrument for testing tubes instead of the regular analyzer. It will also measure high-resistance shorts between any two tube elements.

MILTON REINER\*

**N**O, this is not just "another tube tester." It is a new efficient *tester* that combines the latest requirements with further improvements. Its essential features make it simple to construct and operate and it provides for spare switching capacity that will permit testing tubes that might be brought out equal to double the number of tubes that are on the market today. Moreover, it is decidedly inexpensive to build and may be constructed at a much lower cost than most of the new testers on the market, which do not have the many features of this checker.

The appearance of the instrument is highly professional and is readily adaptable to counter and portable use. The readings give an immediate indication of the condition of the tube under test; the scale of the meter is of the English reading type, or a direct indication of "Good," "Bad" or "Questionable." This eliminates the necessity of referring to a chart to determine whether or not the tube is good or bad.

It is essential that tube testers be calibrated for a definite line voltage and consequently it is also necessary therefore to have a suitable adjustment, so that the applied voltage to the primary of the transformer is always the same, regardless of the value of the line voltage. This is accomplished by means of the A. C. voltmeter M-2, and the rheostat VR1. The voltmeter dial is marked with an arrow,

so that the rheostat can be adjusted to bring the voltmeter pointer exactly over the arrow. For the sake of economy, the voltmeter is designed for 35 volts instead of 120 volts operation, and is connected so as to indicate the secondary voltage of the transformer at the 25 volt tap. As the secondary voltage varies directly with the primary voltage, the indication is as accurate as if the meter were connected directly across the primary and, in addition, the lower range voltmeter costs less. The voltmeter is always in the circuit while the tube is being tested, which enables the operator to make fine adjustment of the line voltage, so that it will not vary according to the amount of load presented by different types of tubes when they are under test. This is an advantage over the use of a single meter, which is used first for line voltage and then for test measurement.

Much has been written about the value of determining  
(Continued on page 240)

\* Chief Engr. Radio City Products Co.

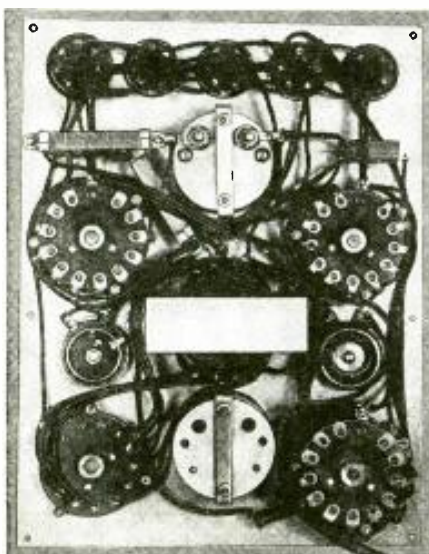
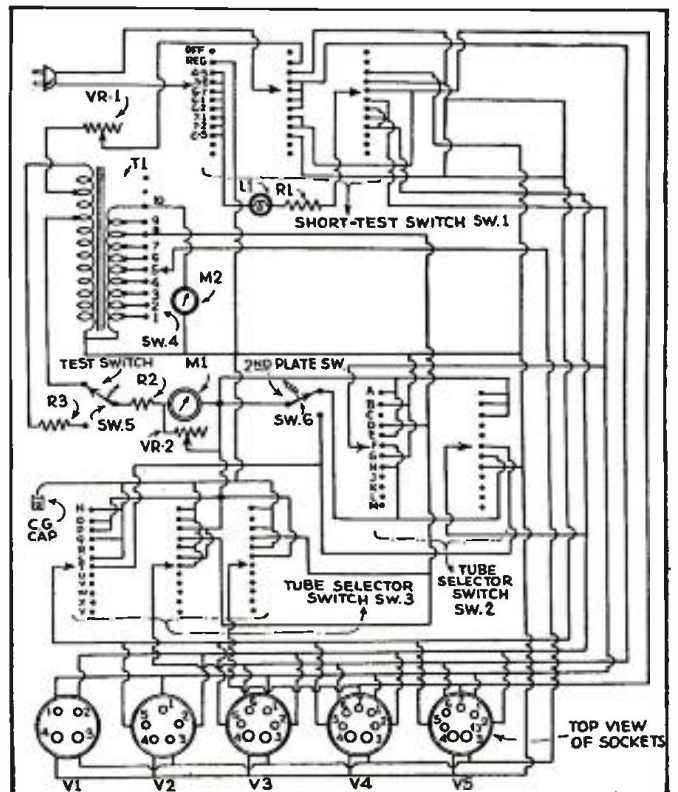

Fig. A, left. Internal construction and appearance of the tube tester. It is compactly constructed.

Fig. I, right. Wiring diagram of the instrument. Spare sockets are included to insure against obsolescence and to eliminate any need for adapters.



# A 100-WATT POWER STAGE

Public address men who have occasion to install amplifier equipment where the requirements are such as to necessitate large outputs—will find this power stage a great aid. It is a low-cost, high-fidelity amplifier, employing new tubes in a class B arrangement.

LOUIS GANCHER\*

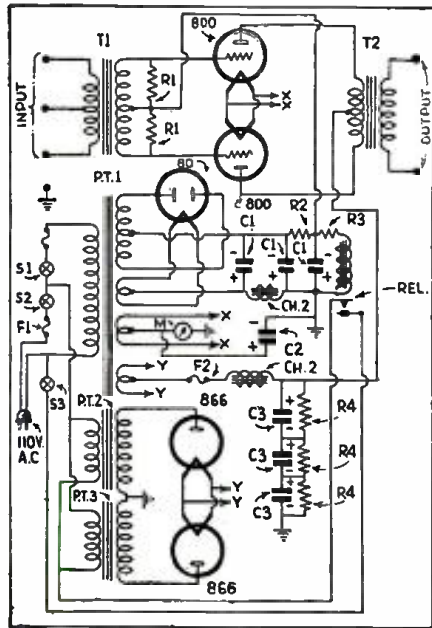

**T**HE unquestionable demand for high-power and high-quality P.A. amplifiers producing undistorted outputs of 100 watts (for application in airports, sound trucks, aeronautical audible advertising, super-power call

\* Pres. Coast to Coast Radio Corp.

Fig. 1, left. Diagram. 2-800's in push-pull, class B; full-wave rectifier; and separate bias arrangement.

Fig. A, below. The extreme compactness and neatness of this 100-watt power stage, also layout, are clearly shown.

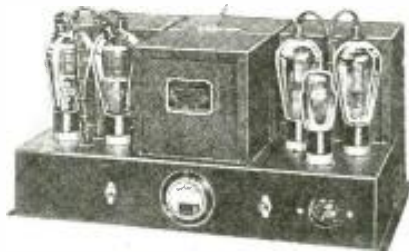

systems for golf courses, country clubs, political conventions, etc.) have never before been satisfactorily met by formerly designed amplifiers, from the following standpoints:

1. Low initial cost of original equipment.
2. Low power consumption.
3. Fool-proof operation.
4. Operating dependability.
5. Light weight.
6. Compactness.

All of these much-desired features have been incorporated into this amplifier by strict adherence to modern engineering principles and by taking full advantage of the latest tube developments and approved applications.

The particular advantage of this arrangement provides for the production of 10 to 20 times the audio power obtainable from the same tube operating in a corresponding class "A" circuit. Low power consumption (which is an

(Continued on page 247)

# A.C. CAR GENERATOR FOR RADIO OR P. A.

The generator described may be easily installed in any car, for power supply purposes. It will deliver 110 volts A.C. for radio, P.A. equipment, or for neon signs.

NAT POMERANZ\*

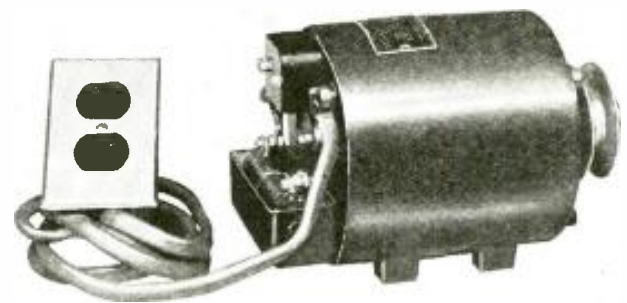
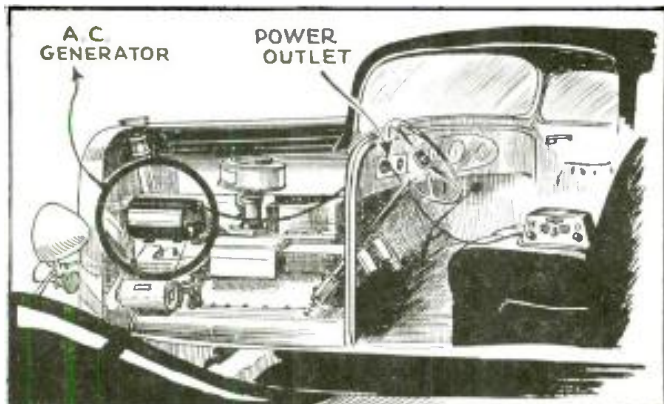

Fig. 1

The installation of this car generator is a simple one. It will deliver 110 volts A.C., for radio, P.A., or lights.



**T**HERE are numerous devices and methods of making a public address installation so that a satisfactory power supply for filament and plate operation of the various tubes is obtained. Unfortunately, such installations, in most cases, must be made permanently or fixed, particularly if they involve gasoline-driven motor-generators. To the author's mind, the best and most appropriate type of installation in a car or truck is one of the portable type. This will permit removing the amplifier or radio equipment for installation in some other place, whenever desired. However, portable equipment for mobile purposes requires special design, considerable extra bulk in the form of extra batteries of the storage type, a motor-generator that will operate from the car battery, and lengthy heavy gauge cables for inter-connecting the set and motor-generator to the amplifier.

But why resort to all that trouble, when a unit such as

(Continued on page 244)

\* Engr. The Powerack Co.

# THE ANALYSIS OF RADIO RECEIVER SYMPTOMS

## OPERATING NOTES

### WHAT THIS DEPARTMENT IS FOR

It is conducted especially for the professional Service Man. In it will be found the most unusual troubles encountered in radio service work, written in a practical manner, by Service Men for you.

Have you, as a professional man, encountered any unusual or interesting Service Kinks that may help your fellow workers? If so, let us have them. They will be paid for, upon publication, at regular space rates.

### CROSLY 148

"RECEIVER dead on receipt at the shop," read the report. The semi-flexible wire-wound 750 ohm type 42 tube bias resistor was badly charred and open at one end necessitating replacement. As soon as operation was restored, it was noted that the set was 40 to 60 kc. off calibration, due, it developed, to tampering with the easily

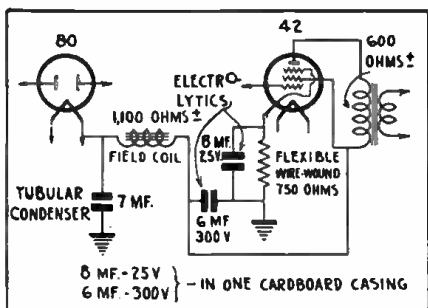
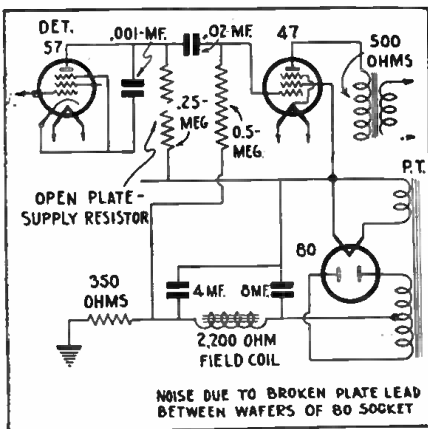

Fig. 2, below  
Sources of trouble in a Belmont 51C.



accessible trimmers. After a thorough alignment the set was fine. See Fig. 1, for the repair. Three months later the same set came in "dead" again, with high plate current in the 80 rectifier circuit and little or no plate or screen-grid voltage at any tube—indicating a short in the power supply. The small dual electrolytic (6 mf., 300 V. and 8 mf. 25 V.) had swollen to quite a size and broken through its cardboard sheath. Shorted, replacement was in order, whereupon the set worked fine. The field coil and 80 tube were carefully checked so as to be sure that the high overload had not damaged them. They were O.K. Another Crosley with identical symptoms and cause, i.e., a poor dual electrolytic, has recently come to the writer's attention and in each case it is believed that chemical disintegration has been the primary cause of condenser trouble.

### BELMONT 51C

THIS set, a midget type, came in "dead." Because of no plate voltage on the 57 detector, the .25-meg. plate supply resistor was suspected and found to be the cause of the trouble. After replacement all seemed to be in order

Fig. 1, left  
"Receiver dead," read the report.

Fig. 3, below  
Fada KW chassis develops condenser trouble. Check by applying high voltage.

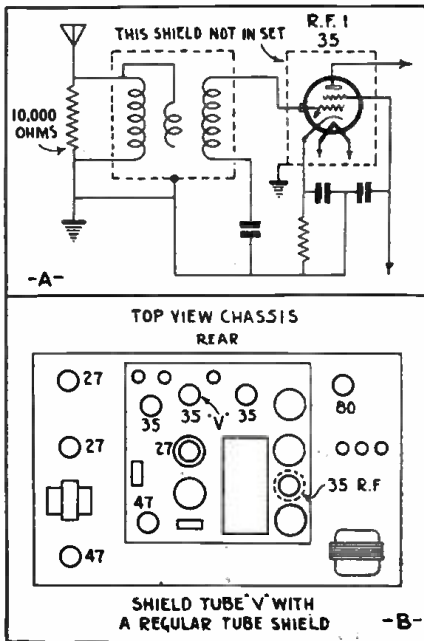

### FADA KW (48-49)

TWO of these sets were in for the same trouble, oscillation, howling and fading. Carefully check all bypass condensers at or above rating in these models. Apply 200 to 600 V., as the case requires, after carefully isolating the condenser under test.

A good spark should occur; reapply a second time and if a second spark results, the condenser is leaky; reapply a third time and then let the condenser, charged, stand for about 5 minutes. Now short it. If the resultant spark is weak, or there is no spark, the job is leaky and should be replaced. Open condensers will take no charge; and shorts are of course immediately evident by any of the regular tests. In the KW jobs serviced here as many as 4 or 5 leaky bypass condensers are usually located in this way. Replace any doubtful ones before anything else is done on the set.

(Continued on page 231)

Fig. 4  
The Edison R-4 goes "haywire."

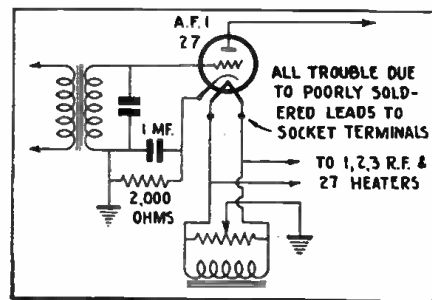



# 2 TUBE SWITCH - TYPE S.-W. CONVERTER

A switching system that eliminates plug-in coils; A.C.-D.C. operation; self-powered; only 2 tubes—with a resultant high translation gain; and complete coverage of the short-wave spectrum, are the features of this converter. It can be connected to any broadcast receiver to permit S.-W. reception.

HERMAN COSMAN\*

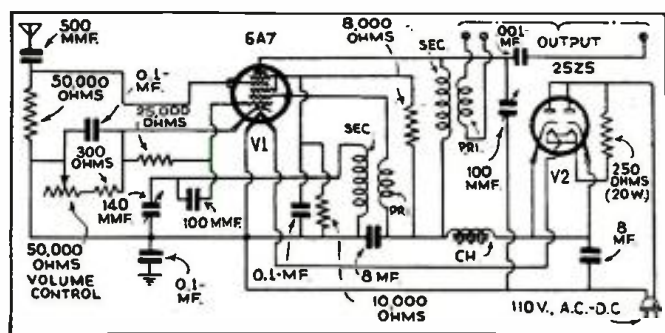
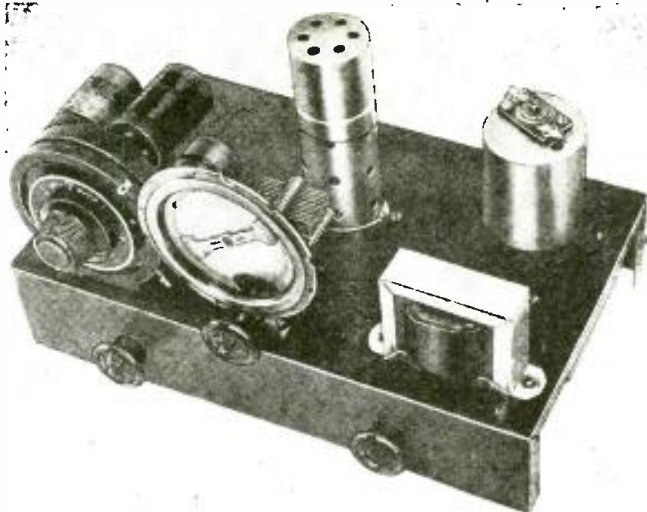

Fig. 1  
Wiring diagram of the 2 tube short-wave converter.

THE converter unit that is described here is considerably more efficient in both design and operation than the conventional converters that have been described previously. In the first place, plug-in coils and their consequent nuisance requirements (plugging in and out for band changing) has been completely eliminated. In their stead is employed an efficient and simple coil-holding and switching assembly. Thus, if the listener-in desires to switch from the 80 meter band to a lower or higher wave-band it is accomplished by the effortless procedure of simply rotating a knob so that the indicator points to the desired position on the accompanying scale.

In addition to this feature, the complete short-wave  
(Continued on page 235)

\* Chief Engr. Try-Mo Radio Co.

# MIDGET TUBE & SET TESTER

This compact little tester includes complete facilities for checking all tubes, besides analyzing and point-to-point tests.

THE MIDGET tester has facilities for measuring all the fundamental electrical circuits of past, present and future radio sets.

It is now possible for the radio service technician to carry but one test instrument, which will always be up to date, no matter what new tubes may be introduced in the industry.

The ranges of this instrument are as follows:

D.C. voltage range (1000 ohms per volt), 5-25-100-250-1000 V.

D.C. current range, 1-10-100-1000 ma.

A.C. voltage range (1000 ohms per volt), 5-25-100-250-1000 V.

Resistance (D.C.), 0.5-5,000,000 ohms.

Resistance (A.C.), 25-3,000,000 ohms.

Capacity, .001-10 mf.

Inductance, 100-10,000 hys.

The A.C. or D.C. voltages encountered in radio sets, sound equipment, and electrical apparatus can be accurately, speedily, and conveniently measured.

Direct current measurements can be  
(Continued on page 236)

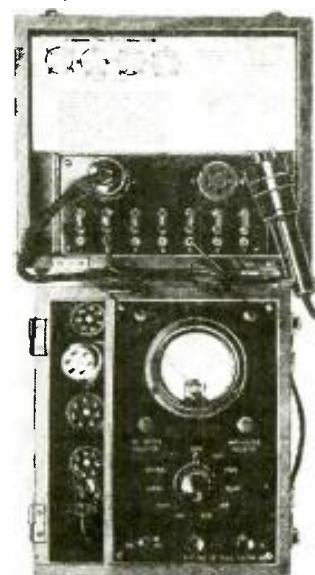
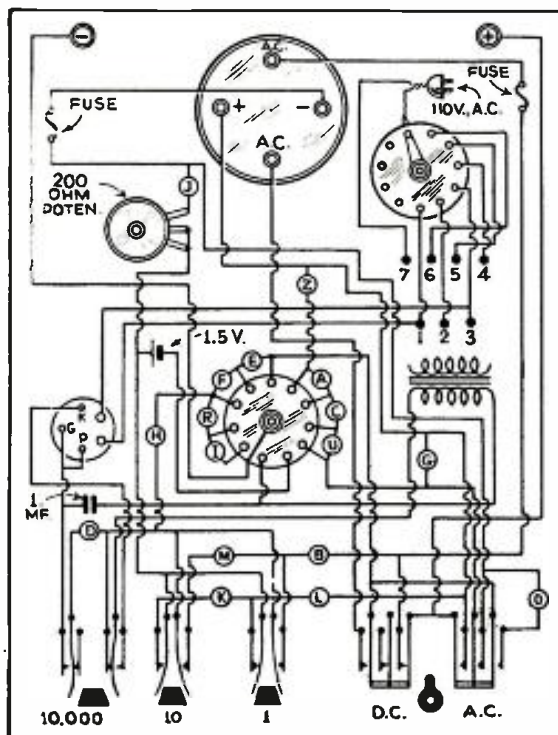

Fig. A, above  
The completed unit is constructed in both sides of the carrying case.

Courtesy, Shallerross Mfg. Company

Fig. 1, left  
Wiring diagram of the midget tester. A "tube transformer" provides all necessary filament voltages for tube tests.

# SHORT-CUTS IN RADIO

**FIRST PRIZE** ..... \$10.00  
**SECOND PRIZE** .... 5.00  
**THIRD PRIZE** ..... 2.50  
**Honorable Mention**

**EXPERIMENTERS:** Three cash prizes will be awarded for the best "short-cuts" — time- and money-saving ideas — submitted by readers of **RADIO-CRAFT**; Honorable mention will be given for all other published items concerning radio and its allied fields.

Send us your "kinks" right away.

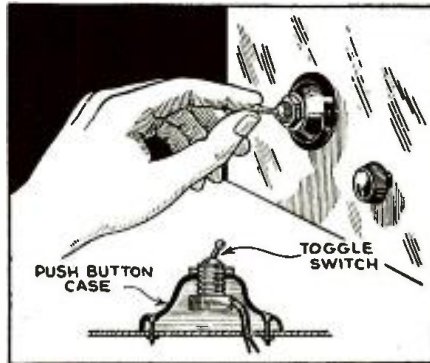

**HONORABLE MENTION.** Use the cases of doorbell push buttons for baseboard mounting of toggle switches.—Joseph Leeb

**HONORABLE MENTION.** Make your own full-vision, vernier-type dial. A defunct shield box yields the disc; trim with a file and clean with steel wool. Scribe and letter in India ink; when dry, coat with clear lacquer. An old bakelite dial will supply the knob. The vernier provides close adjustment.—J. Pilling

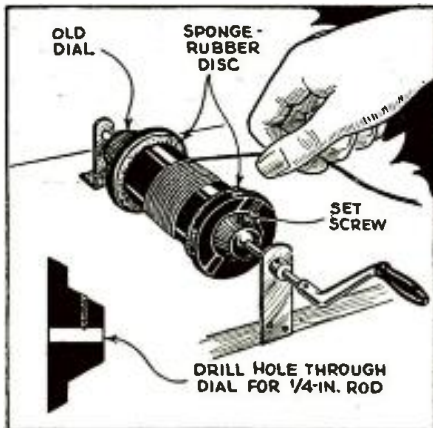

**FIRST PRIZE.** Here is a convenient solution to the problem of quickly making a holder for coil-winding forms of various sizes. Drill through 2 dials and mount as shown.—L. C. Loeffler.

**THIRD PRIZE.** To enhance home-constructed equipment, use "5 and 10" store rubber stamps for hand lettering. For "ink" use white lead thinned with turpentine.—Frank J. Bauer

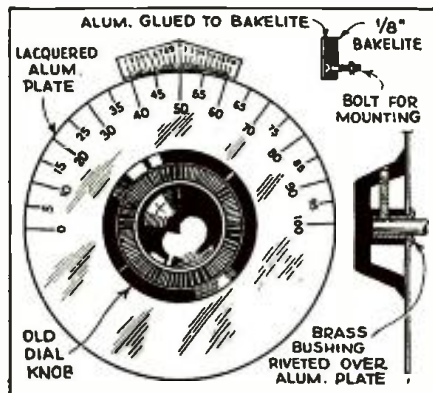
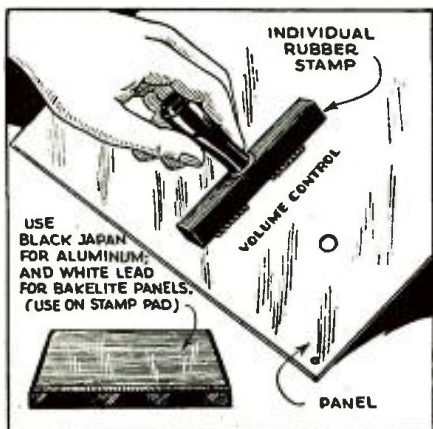

**HONORABLE MENTION.** An idea for the operation of remote experimental equipment. The 2.5 V. pilot light consumes no additional current. The brilliancy of the 40 W. lamp is not noticeably reduced.—Joseph W. Leeb

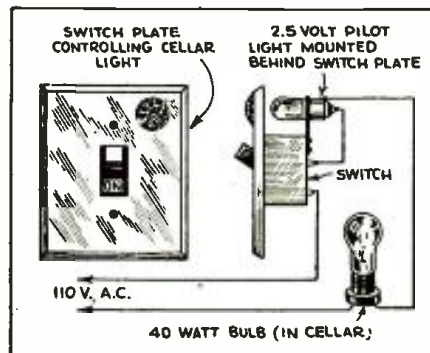

**HONORABLE MENTION.** Rubber caster cups glued to corners prevent damage to test equipment, and to the surface on which it may be placed. Most of the "5 and 10" stores carry these cups.—Frank W. Bentley, Jr.

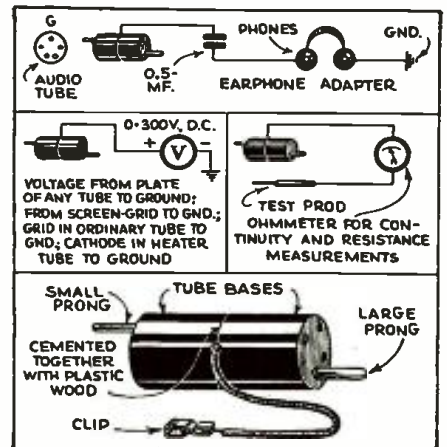

**HONORABLE MENTION.** This simple and handy device can be made in a few minutes from 2 tube bases; 1 small and 1 large prong are connected to a length of flexible wire. Only a few of the many uses are shown.—Wm. R. Moody

**HONORABLE MENTION.** Most "junk boxes," sport at least a pair of headphones—usually, minus the "works." Bend a strip of brass as shown and utilize the cases as ash receivers.—Junior Charlton

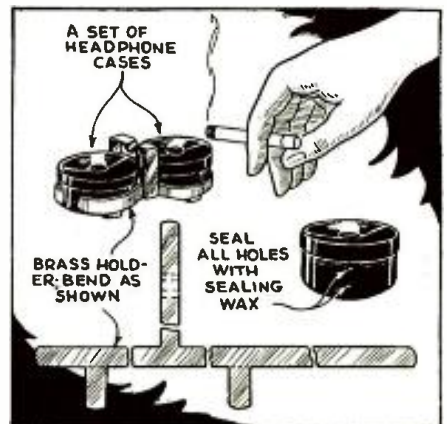

## TUBE-TYPE METER RECTIFIER

Cyril S. Leffrig (Honorable Mention)

THE idea of using two type 99 tubes in a voltage doubler circuit in place of the usual, but much more expensive copper-oxide unit for rectification in connection with an output meter, has proved to be very practical. This circuit and application suggested themselves after an analysis of a standard 25Z5 voltage doubler circuit. Any voltmeter of suitable range may be used as the indicating instrument. The "A" supply consists of two 3 V. "C" batteries. The circuit is shown in Fig. 1.

## "EXTRA SPEAKER" CONTROL CIRCUIT

Joseph Leeb (Honorable Mention)

WHEN connecting an extra speaker to the radio set, the usual practice is to provide a switch at the reproducer, or else leave the switch out entirely. In either case it is not very convenient to shut off the extra reproducer at the radio set, without turning off the set itself. The diagram, Fig. 2, shows a simple method of wiring the extra speaker so that it may be turned on or off, either at the radio set or at the speaker.

## "OUTPUT METERING"

T. B. Sherzer (Honorable Mention)

WITH the addition of a few extra items to your present analyzer—any vintage; any type—you can make accurate output comparisons on your plate milliammeter. It is only necessary to break 2 easily-located leads. All the additional parts are in your junk box right now. Values are not critical. Either linear or current-squared readings may be readily taken. This arrangement, for servicing use, is equal or superior to the rectifier-type commercial output meter, not just a make-shift.

The principle is simple: referring to Fig. 3A, G, normally, is held at some value, usually negative, through the set socket and analyzer plug and cable. Circuit C1, R, allows the bias on G to be moved at will to a point where plate

rectification will take place. This rectified value will deflect a D.C. milliammeter, whereas if G were fed an A.C. voltage having the normal bias as a node, the D.C. milliammeter in the analyzer would show very little deflection. (You simply move the tube from class A to class B operating conditions.)

Locate the lead to the G prongs of the socket gang, remove from G and solder to A. Run lead from G, to G on switch, as shown at A and B in Fig. 3.

Next, locate the lead to the P prongs of the socket gang, remove from P and solder to point B. Run a lead from P to P.

Then, run a lead from K to the K prong on any 5, 6 or 7 prong socket in the gang except those for pentodes, such as the 47 and similar direct-heater tubes.

FCT may be connected to any filament prong, or better, the center of a tapped resistor across the filament prongs.

If your analyzer has a reference selector, omit Sw. 4 and run lead d to the selector arm.

Remove both power tubes. Insert one in correct analyzer socket. Insert analyzer plug in its place. Set the selector for plate current readings. Set the range as usual for the type tube used, and turn on the radio set. Adjust R to the lowest stable reading for linear output measurement, or to the bend in the tube characteristic for current-squared comparisons. Turn on the service oscillator and proceed.

The circuit shown at A in Fig. 1 works fairly well except that it is very noisy. Getting tired of reaching into cramped spaces in order to make connection with the voice coil, the circuit shown at B was evolved. The latter connection is silent and is much preferred by the writer.

Condenser C1 is a .01-mf. mica fixed condenser; C2, C3, 2 to 6 mf., 1000 V., paper, best-quality fixed condensers. Resistor R is of compression type, with a maximum value of 1. meg. Unit L is an A.F. transformer primary or 30 hy. choke coil. Switches Sw. 1 to Sw. 3 are, respectively, S.P.S.T., S.P.D.T., S.P.S.T., and are commercially available in a ganged unit; switch Sw. 4 is an S.P.D.T. unit. Note that, if C2 or C3 goes—so does your meter!

(Continued on page 242)



Fig. A.

The time-switch clock in the course of construction. At extreme right is shown the "vacuum contact" tube.

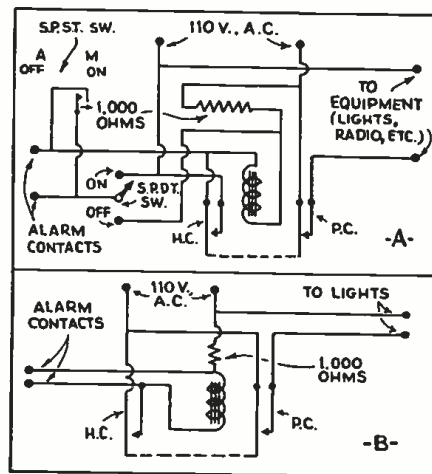

Fig. 5.

Schematic circuit of the self-locking relay used in the time switch.

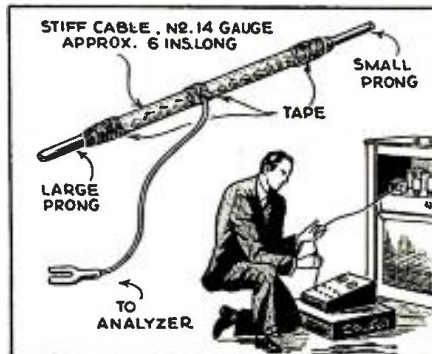

Fig. 4, above.

One of the several leads constituting a cable with out an adapter, is shown.

Fig. 1.  
Type 99 tubes as meter rectifiers.

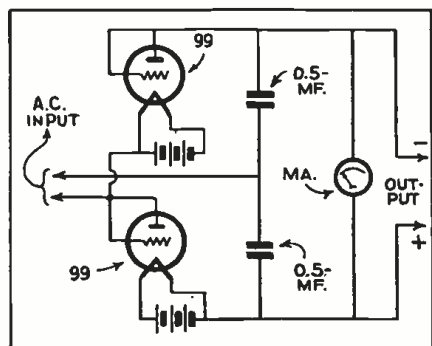

Fig. 2.  
A combination remote and local switching arrangement permitting extreme flexibility in operating supplementary speakers.

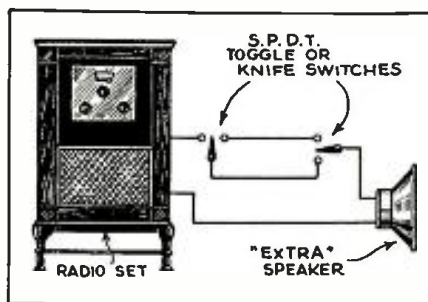
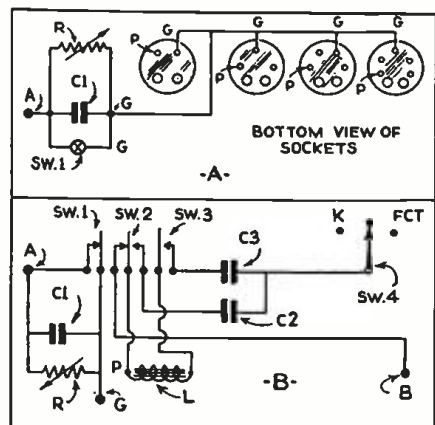

Fig. 3, below.  
Circuits for output meter servicing.



# READERS' DEPARTMENT

A department in which the reader may exchange thoughts and ideas with other readers.

## CONVENIENCE PLUS

Editor, RADIO-CRAFT:

Here is a kink that may be of value in the radio service field. I have used it in my shop for about two years and think it is a very valuable installation, and the cost is very small.

The accompanying photo is almost self-explanatory as you may see that the equipment is suspended on a carrier track, or trolley which easily conveys the equipment from one bench to the other without the loss of time, and is always up out of the way.

For example the system works out this way: "Mr. Jones brings his radio set into the shop to be repaired, and says he will return for it 24 hours later. The testing equipment is put in place, the work nicely started, when Mr. Smith comes in with his receiver and informs us that he wants his set repaired immediately because there is a special program on, and he wants his set in two hours. Here is where the carrier comes in handy. As Mr. Jones did not want his set right away, we push the equipment over to Mr. Smith's set and proceed testing his receiver. After Mr. Smith's difficulties have been adjusted, the equipment is returned to Mr. Jones' set without loss of time. The same results could be otherwise obtained, but not so quickly and would tie up more equipment, if this arrangement were not employed.

The phono pickup on top of test equipment is used for testing audio circuits and demonstrating the quality that may be had from a record through a radio receiver.

One of the benches is equipped to test battery sets and the other to test electric sets. The battery bench is equipped with  $\frac{1}{4}$  A. fuses in each lead to protect the batteries and tubes in case of a short circuit. There is a switch which inserts a 10 W. lamp in series with the "B" supply when locating a short circuit.

Separate aerial and ground connections are available on both benches through clips and switch arrangements.

More details can be furnished if necessary.

V. V. NILES  
1014 Ninth Ave.  
Greeley, Colo.

This is certainly a convenient method for moving testing equipment from one job to another in the shop. We believe that many dealers and Service Men can use the same idea or a similar one to increase the speed and efficiency with which they repair sets. Thanks for your idea, Mr. Niles.



Servicing equipment on a "trolley line."

## A BOUQUET FROM TEXAS

Editor, RADIO-CRAFT:

I have represented over 100 different trade and technical journals during the past 20 years and find RADIO-CRAFT is read, preserved, and generally liked by the profession it serves, better than any journal or class publication I ever sold. This was proved to me on my recent trip over a wide territory, viz., every city and town between Houston, San Antonio and Brownsville. A party here in the valley wanted an entire file of 1932 back copies of RADIO-CRAFT, and I found many Service Men with a file of old copies on hand and offered to pay \$2.50 for the twelve 1932 copies but not a single Service Man who had them would part with same. They save them for reference. I would often make the statement, "can you offer any suggestion for improving RADIO-CRAFT or what department do you like best." Their answer invariably would be—I like all departments and would leave RADIO-CRAFT as it is.

Why, the technicians point to their file of RADIO-CRAFT with as much pride as they do their test instruments!

JOHN I. NELSON  
McAllen, Texas

One way to attract attention.



Thank you, for your complimentary letter, Mr. Nelson. We are glad to know that RADIO-CRAFT readers in your territory are pleased with our magazine. We are endeavoring constantly to improve RADIO-CRAFT, and careful readers will note the change in style, layout, and editorial contents. It is our hope that this change is an improvement which will appeal "just as much" to our readers. If any reader feels that the magazine contents should be changed, or has any criticism whatsoever to offer concerning the material published we will be only too glad to receive these comments and act upon them, if possible.

## NUMEROLOGY IN SERVICING

Editor, RADIO-CRAFT:

Would you be interested in the enclosed photograph of Ford V-8 Sedan Delivery operated by the Cunningham Radio Service, 1710-1712 Leeland Ave., Houston, Texas, George H. C. Cunningham, proprietor?

As you will notice, all three of the phones listed by the Cunningham Radio Service are composed entirely of the numeral "7"—Wayside 7777, Fairfax 7777 and Capitol 7777. In addition, the license number of the automobile is 7777 for 1934.

Another unique feature is that this radio shop deals exclusively in "Cunningham Radiotrons," which is in itself an advertising asset to my business, since the name "Cunningham" is invariably linked with radio.

CUNNINGHAM RADIO SERVICE  
Crawford at Leeland  
Houston, Tex.

## "ALL-WAVE ANTENNAS"

Editor, RADIO-CRAFT:

It may interest you to know that there are a number of rather glaring errors in R. D. Washburne's article entitled, "Important Facts About the New All-Wave Antenna Systems," appearing in the August issue.

On page 85, Fig. 2, the antenna post of the receiver is shown grounded, which obviously will not work. Under the sub-heading, "A High-Quality Doublet Antenna System," it is stated that the "two downloads should be kept as far apart as possible, within reasonable limits, if the shortest wavelengths are not to be too greatly attenuated." The exact opposite is true. On page 107, under "All-Wave Transposition Cable," last paragraph, it states that "By res-

(Continued on page 258)

GENERAL ELECTRIC MODEL C-61 6 TUBE "DE LUXE" CAR-RADIO RECEIVER

(This set incorporates the new type 6D6 tube. The total average "A" consumption is 8 A. A tone control is provided; also, there is a manually-operated sensitivity or noise-suppressor control. The circuit incorporates A.V.C. The chassis is designed for convenient servicing.)

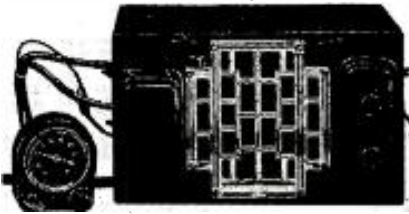

The newest in automotive radio sets.

Ease of installation, accessibility for servicing, ruggedness of construction and high-quality reproduction are features of this set. Sensitivity and tone controls are located on the right panel of the receiver proper.

This set has a frequency range of 540 to 1,600 kc. The "A" consumption of the field coil (cold) is 1.35 A.; the tubes consume 2.2 A., and the dial light, .15-A.; the power supply consumes 2.8 A. (no signal). The maximum undistorted output of this set is 6.8 W. The vibrator inverter-rectifier is of plug-in type. A 20 A. fuse is used.

The secondary of the second I.F. transformer is divided into 2 sections, wound in opposite directions; the sections are shown in the schematic circuit as L10 and L18. The purpose of this construction is to avoid vibrator interference pick-up due to circulating currents in the chassis case.

The A.F. driver stage, V5, utilizes a pentode connected for operation as a triode. The sensitivity control, R2, varies the degree of noise suppression. The ganged variable condenser nearest the I.F. transformers is the oscillator section; next comes the second-detector circuit tuning condenser, followed by the R.F. circuit tuning condenser.

In the event that interference originating with the vibrator inverter-rectifier unit is

encountered, check the following points:

(A) Vibrator not properly seated. The vibrator must be pushed tight against its socket at all times.

(B) The clip from the top of the R.F. tube shield of the gang-condenser must be in place.

(C) The various bypass condensers, such as C29, C30, C31, C34, C37, and chokes L16, L14 and L13, must be correctly connected, and in operating condition. It is well to remember that some of the interference produced by the vibrator is of a frequency as high as 1 meter and any replacement of condensers must always be made with ones of similar mechanical as well as electrical construction.

The following are the voltages at the tube socket while the receiver is in operating condition. No allowance has been made for current drawn by the meter and if low-resistance meters are used, such allowances must be made.

The battery rating for these figures is 6.3 V.; the set is adjusted for no signal and maximum sensitivity. All the voltages in this tabulation are read to ground.

Tube Type	Cath. Volts	C.-G. Volts	Plate Volts	Cath. Ma.
V1	3.9	76	192	4.5
V2*	3.9	76	192	7.5
V2**	3.9	—	192	7.5
V3	3.6	76	192	5.3
V4	1.25	—	165	.46
V5	22.	—	235	14.5
V6	0	—	256	10.5

\*First-detector section; \*\*oscillator section.

The resistance value of inductances is shown in parentheses. The aligning screws of the I.F. transformers are accessible from beneath the chassis. The I.F. aligning procedure is as follows:

Short-circuit the antenna and ground leads and tune the receiver so that no signal is heard. Set the volume control at maximum and

connect a ground to the chassis.

Next, connect the oscillator output between the first-detector control-grid and chassis ground. Connect the output meter across the voice coil of the loudspeaker and adjust the oscillator output so that with the receiver volume control at maximum, a slight deflection is obtained in the output meter.

Finally, adjust the primary of the second, and the secondary and primary of the first I.F. transformers, until a maximum deflection is obtained on the output meter at all times. Go over these adjustments a second time, as there is a slight interlocking of adjustments.

To align the R.F. and oscillator condenser sections, first connect the service oscillator to the antenna and ground lead of the receiver, and turn the tuning control until the tuning condensers are fully meshed. Then set the indicator on the dial at the 530 kc. reading. Turn the tuning control until the dial reads 1,400. Then set the service oscillator at 1,400 kc. and connect the output meter across the voice coil. Adjust the 3 gang variable condenser trimmer screws until maximum output is obtained. Be careful not to disturb the relation of the control box to the receiver after setting the dial.

After making the 1,400 kc. adjustment, shift the service oscillator to 600 kc. and tune in the signal. Adjust the 600 kc. trimmer, accessible from the side of the chassis, for maximum output while rocking the condenser gang back and forth. Then again check the adjustment as described in the preceding paragraph.

When making both the I.F. and R.F. adjustments, the important point to remember is that the receiver volume control must be at its maximum position and the minimum input signal necessary from the oscillator must be used.

Vibrator defects should be remedied by replacement, not by attempted adjustment (special equipment is used at the factory for this purpose).

Schematic circuit of the newest G.E. car-radio set. The receiver is made in 2 sections so that the chassis may be lowered for servicing.

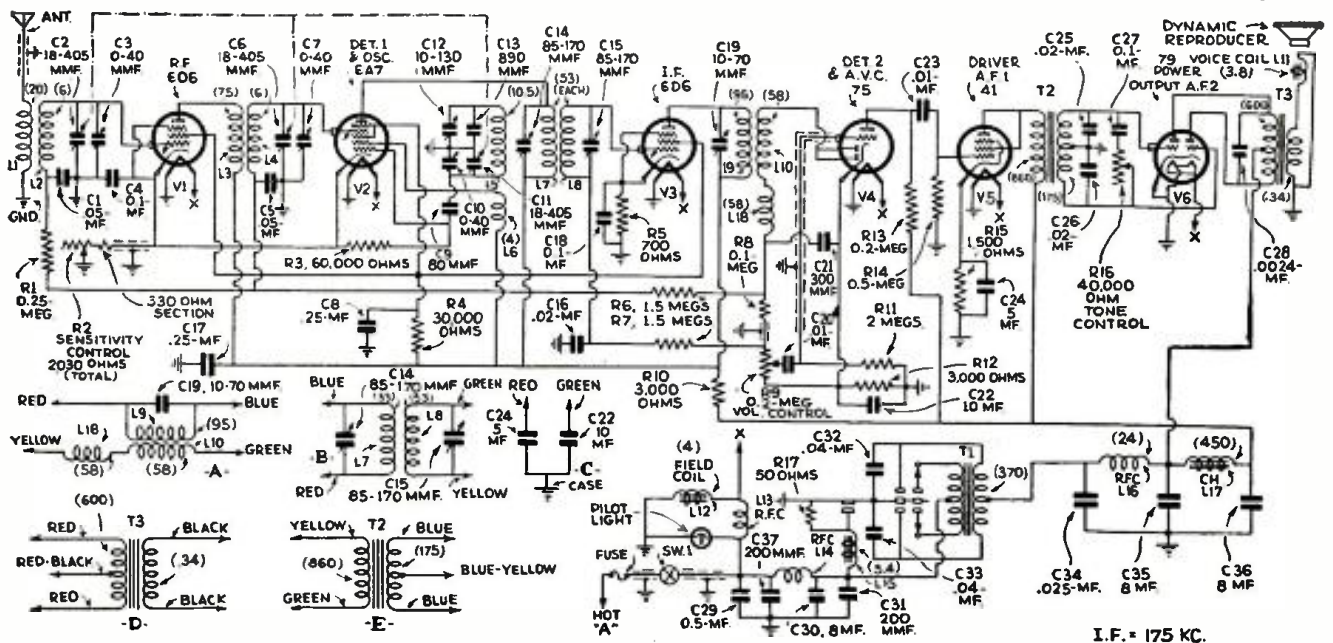

I.F. = 175 KC.

# RADIO-CRAFT'S INFORMATION BUREAU

## A 2 TUBE LOUDSPEAKER A.C.-D.C. REFLEX SET

(289) Mr. Curtiss A. Brown, Bronx, N. Y.  
(Q.) Is it possible to make a 2 tube electric set that will operate a loudspeaker?

(A.) It is possible not only to build a 2 tube set, but also a 1 tube receiver (RADIO-CRAFT, May 1934, page 656—"How to Make a 1 Tube Loudspeaker Set").

The schematic circuit of a 2 tube set that will operate a loudspeaker very satisfactorily, using only a small aerial, is shown in Fig. Q. 289. The circuit is reflexed. The following list of parts for the circuit is published by courtesy of Mr. H. G. Cisin, who developed the actual instrument.

1, .006-mf.; 2, a set of 4 plug-in shortwave coils, 15 to 200 meters, and a broadcast coil, 200 to 550 meters; 3, 140 mmf.; 4, 100 mmf.; 5, 7 prong socket and 6F7 tube; 6, 100 mmf.; 8, 1 meg., 0.5-W.; 9, 50,000 ohms, 0.5-W.

10, 75,000 ohms; 11, .01-mf.; 12, 50,000 ohms, 0.5-W.; 13, 50 mmf.; 13A, 50,000 ohms, 0.5-W.; 14, 0.1-mf.; 14A, 5,000 ohms, 0.5-W.; 15, 150 mmf.; 16, 1 set of short-wave coils (with primary modified), a broadcast coil (with primary modified), and a 4 prong socket; 17, 4 mf. electrolytic; 18, 100 mmf.; 19, 0.1-meg., 0.5-W.

20, .01-mf.; 0.2-meg.; 0.5-W.; 22, 19 mmf. electrolytic; 23, 1000 ohms, 0.5-W.; 24, 7 prong socket and 12A7 tube; 25, 5,000 ohms, 0.5-W.; 26, .006-mf.; 27, magnetic speaker; 28, 4 mf., 150 V. electrolytic; 29, 4 mf.; 30, 340 ohms, 50 W.; 31, off-on switch.

The chassis measures 9 x 4 1/4 x 1 3/4 ins. high.

The 6F7 tube consists of two separate units, one a pentode and the other a triode. The pentode unit serves as the first R.F. tube, while the triode unit is used as the detector. By means of a reflex circuit, the pentode unit is again utilized—this time as a first A.F.

The 12A7 tube combines the functions of a power output pentode and a rectifier unit. As in the case of the 6F7 tube, the two units are both mounted within the same envelope.

The coils must be altered as follows. First remove the small winding on the bottom of the form. Then wind an inter-winding between the turns of the secondary. The number of turns should equal two-thirds of the particular coil being changed. Number 34 or 36 enameled wire should be used. The new winding should be connected to the prongs in place of the one which was removed.

## PARTS VALUES OF "POWERIZER" MODELS AK AND R-20

(290) Mr. R. E. Stiles, Albany, N. Y.  
(Q.) I have a "Powerizer" unit model PXY1, 110 V., 60 cycles, using a type 10 and type 80 tube. The condenser block is apparently shorted. What I want to know is the value of these condensers in the block as well as the values of the other parts in the unit. Also, could electrolytic condensers be used?

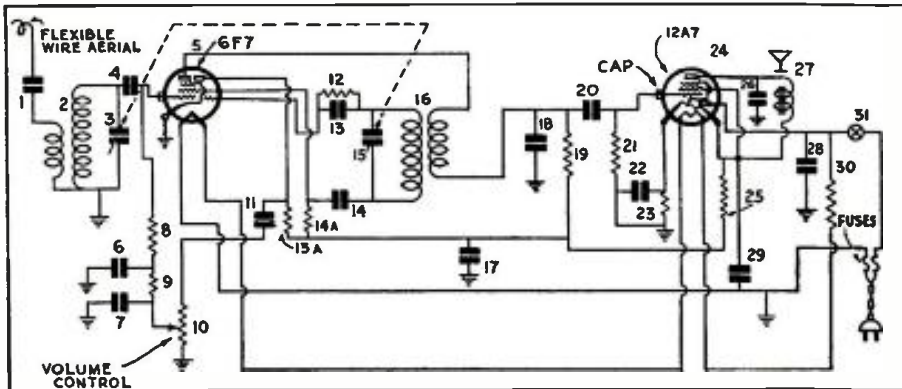

(A.) We have received from the Radio Receptor Co., the information requested. The schematic circuit of power-amplifiers AK and R-20, which constitute the PXY series, is shown in Fig. Q.290.

At resistor terminal B the voltage is approximately 40 V., at C, 90 V.; at D, 350 V. As many as 8 type 26 tubes can be accommodated on the filament winding designed for this tube; 2 type 27s may be operated from the corresponding secondary. Resistor R1 (red) has a value of 1,600 ohms; R2, (black), 700 ohms.

Electrolytic condensers may be used to replace the individual capacities in the condenser block, if they have a sufficiently high working voltage.

## "5 TUBE PORTABLE SET"

(291) Mr. Clifford Abt, Long Island City, N. Y.

(Q.) I am very much interested in the "5 Tube Portable Set" by Mr. R. M. Dean, in the August, 1934, issue of RADIO-CRAFT, but find that some of the figures do not agree. I find that the values for the condensers connected to the oscillator coil of the first-detector, as printed on the diagram, do not agree with those given for similarly numbered condensers in the List of Parts. Reference is made to condensers C1, C2, C2A and C3. What is the correct arrangement of these components?

(A.) A correct detail of the circuit mentioned above is shown in Fig. Q.291.

## FINDING "PADDING CONDENSER" CAPACITY

(292) Mr. P. J. Prosser, Tulsa, Okla.

(Q.) What are the factors that determine the value of the "padding" condenser used in series with the oscillator-circuit tuning condenser in a superheterodyne? Of course, this condenser establishes the correct circuit capacity at the maximum setting of the tuning condenser, as contrasted with the "trimmer" condenser, in shunt to the tuning condenser, which determines the effective minimum capacity of the tuning condenser, but the question arises as to why a particular value is chosen for the "padding" condenser.

(A.) Disregarding for a moment the question of whether the connection of two condensers in series being connected in shunt to a coil is employed in the oscillator section of a superheterodyne, or any other specific service, the diagram is analyzed in a more fundamental manner, by reference to Fig. Q.292, as follows.

A tuned circuit consists fundamentally of a coil in series with a condenser, as shown in Fig. 1A. If we induce a constant voltage into such a circuit and measure the current flow around the circuit as the frequency of the induced voltage is varied we would find a typical resonant characteristic between the current and the frequency, provided the frequency was varied above and below the resonant frequency of the circuit.

(Continued on page 243)

## SPECIAL NOTICE

Those questions which are found to represent the greatest general interest will be published here, to the extent that space permits. (At least 5 weeks must elapse between the receipt of a question and the appearance of its answer here.) Mark such inquiries, "For Publication."

Replies, magazines, etc., cannot be sent C.O.D. Back issues of RADIO-CRAFT prior to December, 1932, are available at 50c per copy; except the following issues: 7/29, 2, 3, 4, 6, 7, 9 and 11/30; 5, 8 and 9/31; and 10/32, which are out of print. Succeeding issues are still available at the regular price of 25c per copy.

Inquiries to be answered by mail MUST be accompanied by 25c (stamps) for each separate question; answers are subject to subsequent publication if considered of exceptional interest.

Furnish sufficient information (in reference to magazine articles, be sure to mention issue, page, title, author and figure numbers), and draw a careful diagram (on separate paper) when needed to explain your meaning; use only one side of the paper. List each question. Be SURE to sign your name AND address.

Enclose only a STAMPED and self-addressed envelope for names and addresses of manufacturers; or, in connection with correspondence concerning corrections to articles, as this information is gratis.

Individual designs can be furnished at an additional service charge. The fee may be secured by addressing the inquiry to the SPECIAL SERVICE department, and furnishing COMPLETE specifications of desired information and available data.

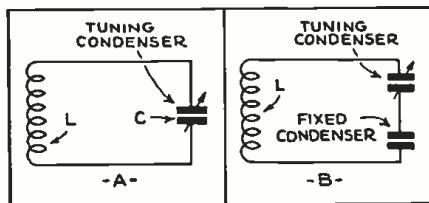

Fig. Q. 292.

Adding a padding condenser to a circuit.

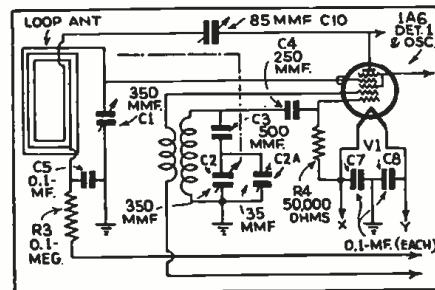

Fig. Q. 291.

Corrected, schematic circuit detail.

Left, Fig. Q. 289.

A 2-tube reflex for loudspeaker operation.

Below, Fig. Q. 290.

Receptrad "Powerizer" models AK and R-20.

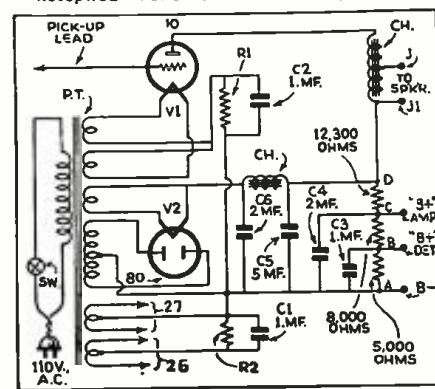

# Radio Men!

**GOOD BOOKS WHICH HELP  
MAKE RADIO WORK MORE PROFITABLE**

Presented on this page are books of the RADIO-CRAFT LIBRARY SERIES—a most complete and authentic set of volumes treating individually, important divisions of radio. Each book has been designed to give radio men the opportunity to specialize in one or more of the popular branches of the industry. You will find them a real help in your work and they will contribute to your money earning capacity. Read these books during your spare time at home.

The authors of these books are well-known to everyone. Each is an expert radio man; an authority on the subject—each is thoroughly familiar with the field which he represents.

This is the first real opportunity that you have ever had to build a library of radio books that are authentic. **MOST OF THE BOOKS HAVE BEEN RECENTLY REVISED AND REWRITTEN TO KEEP THEM UP TO THE MINUTE.** Mail coupon below for your books.

**Book No. 1**  
**Radio Set Analyzers**  
And How To Use Them  
By L. VAN DER MEL  
With Full Instructions and Descriptions of Set Analyzers, Tube Checkers, Oscillators, etc. (Just revised.)

**Book No. 2**  
**Modern Vacuum Tubes**  
And How They Work  
By ROBERT HERTZBERG  
With complete Technical Data on All Standard and Many Special Tubes. (Just revised.)

**Book No. 3**  
**The Superheterodyne Book**  
All About Superheterodynes  
By CLYDE FITCH  
How They Work, How to Build and How to Service Them.

**Book No. 4**  
**Modern Radio Hook-Ups**  
The Best Radio Circuits  
By R. D. WASHBURNE  
A Complete Compendium of the Most Important Experimental and Custom-built Receivers.

**Book No. 5**  
**How to Become a Radio Service Man**  
By LOUIS MARTIN  
How to get started in the business of servicing radios and how to make money in this field.

**Book No. 6**  
**Bringing Electric Sets Up to Date**  
By CLIFFORD E. DENTON  
With Pentodes, Multi-Mus. Dynamic Speakers—Complete Information How to Modernize A. C., D. C. and Battery Operated Receivers.

**Book No. 7**  
**Radio Kinks and Wrinkles**  
By C. W. PALMER  
For Service Men and Experimenters  
A Complete Compendium on the Latest Radio Short-Cuts and Money Savers—These Kinks Are Great Time-Savers.

**Book No. 8**  
**Radio Questions and Answers**  
By R. D. WASHBURNE  
A Selection of the Most Important of 5,000 Questions Submitted by Radio Men During the Course of One Year—They Are All Answered by a Technical Expert.

**Book No. 9**  
**Automobile Radio and Servicing**  
By LOUIS MARTIN  
A Complete Treatise on the Subject Covering All Phases from Installing to Servicing and Maintenance. A Book That is Greatly Needed Today. (Just Revised.)

**Book No. 10**  
**Home Recording and All About It**  
By GEORGE J. SALIBA  
A Complete Treatise on Instantaneous Recordings, Microphones, Recorders, Amplifiers, Commercial Machines, Servicing, etc.

**Book No. 11**  
**Point-to-Point Resistance Measurements**  
By CLIFFORD E. DENTON  
The Modern Method of Servicing Radio Receivers—A Book Which Radio Service Men Have Referred to More Than Any Other.

**Book No. 12**  
**Public Address Installation and Service**  
By J. T. BERNSELY  
Modern Methods of Servicing and Installing Public Address Equipment.

**Big Discount To You**

In order to make it possible for everyone to buy these books, the fifty (50) cent price has been made uniform for all volumes. You can buy these books separately, but you should take advantage of our special offer:

**When Five (5) Books Or More Are Ordered Deduct 20% From Your Remittance**

Simply fill in the coupon at left, and mail it to us together with your remittance. Checks, stamps or money orders accepted.

**Here are the subjects covered--**

- Set Analyzers
- Tubes
- Superheterodyne Circuits
- Radio Hook-ups
- Servicing Business
- Modernizing Electric Sets
- Kinks and Wrinkles
- Questions and Answers
- Auto-Radio Servicing
- Home Recording
- Resistance Measurements
- Public Address

**All Books Uniform** Volumes are all uniform size, 6 x 9 inches, and contain on an average of 50 to 120 illustrations. Each book is printed on fine paper and no expense has been spared to make it an outstanding value.



**CLIP—MAIL THIS COUPON TODAY!**

GERNSBACK PUBLICATIONS, INC., 99 Hudson Street, New York, N. Y.

I have circled below the numbers of books in the RADIO-CRAFT LIBRARY SERIES which you are to send me, and have deducted 20% for ordering five (5) books or more. I have included my remittance in full, at the price of 50c each, when less than five books are ordered.

The amount of my remittance is.....(Stamps, checks or money orders accepted.)  
Circle numbers wanted: 1 2 3 4 5 6 7 8 9 10 11 12

Name ..... Address .....

City ..... State ..... BC-1084

WURLITZER LYRIC MODEL C/M-4 4 TUBE REGENERATIVE REFLEX A.C. SUPERHET. CHASSIS

(Uses a 6A7, 6B7 [reflexed], 43 and 25Z5 [voltage doubler] tube. Incorporates A.V.C.; also, a range-change switch for reception from 1,500 to 4,000 kc. The reproducer field coil is utilized as the only filter choke. Chassis is used in models C-4-L, C-4-LI, M-4-L, M-4-LI and SA-46 receivers.)

The only difference between the Lyric models C-4 and M-4 receivers is the placement of the volume control and gang condenser. On the model C-4 the volume control is mounted on a bracket at the left, and the gang condenser on the right. On the model M-4 the volume control is mounted below the gang condenser on the right. For this reason the chassis is usually referred to as the C/M-4.

The early C/M-4 is a single (broadcast) band receiver. The later models have an additional short-wave band, approximately 1,500 to 4,000 kc., which is selected by a toggle switch at the right rear of the chassis pan. There are no calibration or alignment adjustments to make on this band. For short-wave reception the switch must be turned toward the end of the chassis pan; for broadcast reception, toward the center of the chassis pan.

In this receiver the 6A7, V1, functions as a combined oscillator and first-detector; the 6B7, V2, as a first I.F., regenerative second-detector, A.V.C., and first-A.F.; the 43, V3, functions only as a second A.F. The 25Z5 is connected as a voltage doubler.

Operating voltages at various points

in the circuit are indicated on the diagram. Readings are taken with all controls turned on full and no signal. Use a 1000-ohms-per-volt voltmeter. Use 300 V. scale, except at points marked (\*), when a 7.5 V. scale should be used.

In all ganging operations, use the weakest signal that will give a satisfactory indication on the output meter. Do this by reducing the input, *not by retarding the volume control.*

Inasmuch as this set utilizes the tubes to their utmost capacity, the 6B7, V2, being reflected for both I.F. and A.F. amplification, the I.F. trimmer adjustments are very critical. For this reason, and because these adjustments are carefully made at the factory, the alignment of the I.F. trimmers is not recommended, although the procedure is as follows.

Attach the output meter from screengrid to plate of the 43, V3, and advance the volume control clockwise to its maximum position. Attach the antenna lead to the service oscillator tuned to 456 kc. Keep the input from the service oscillator as low as possible, and adjust the I.F. trimmers for maximum reading on the output meter.

The first I.F. trimmer is located under the chassis pan, adjusting through a hole in the chassis pan, near right-center, directly in front of the first I.F. transformer. The slot adjustment is the primary trimmer; the hexagonal nut is the secondary trimmer.

The second I.F. trimmer is located under the chassis pan, adjustable through a hole in the chassis pan, left-center, near the volume control.

To calibrate the C/M-4 chassis, turn the toggle switch (if any) to the broadcast position and set the gang condenser to the position where a station or service oscillator signal of

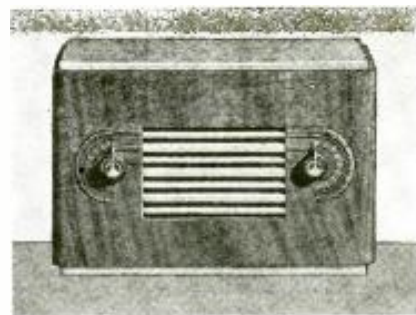

Model C/M-4 chassis in model C-4-LI set.

about 1,500 kc., can be received. Adjust the set oscillator trimmer (screw adjustment, top of gang condenser, front end) until the desired signal is heard. The calibration of the rest of the dial will fall within reasonable limits without further adjustment.

To align or gang the C/M-4 chassis, turn the toggle switch (if any) to the broadcast position, connect the output meter from screen-grid to plate of the type 43 tube, and turn the condenser to approximately 1,400 kc. Connect the antenna lead to the service oscillator turned to the set, and check the setting of the volume control.

Adjust the R.F. trimmer (screw adjustment, rear end, top of gang condenser) until the output meter indicates maximum output. *Keep the signal input low.* The alignment of the balance of the tuning range will fall within reasonable limits with no further adjustments.

The particular circuit shown is that of the serial series 3,700,001. In circuits of this type, where the tubes are called upon to perform a multiplicity of services, the tolerance of the components is very small. For this reason it is essential that accurate components, having rated values, are used in replacements.

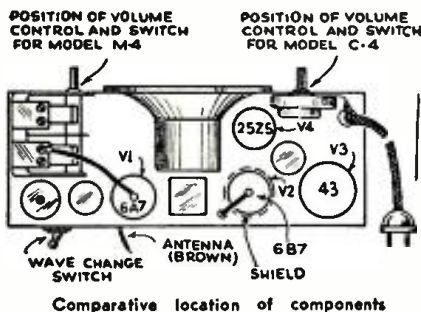

Comparative location of components

Schematic circuit of Wurlitzer Lyric model C/M-4 receiver chassis. The 6B7, V2, is reflexed for operation as I.F., second-detector, A.V.C. and A.F.I.

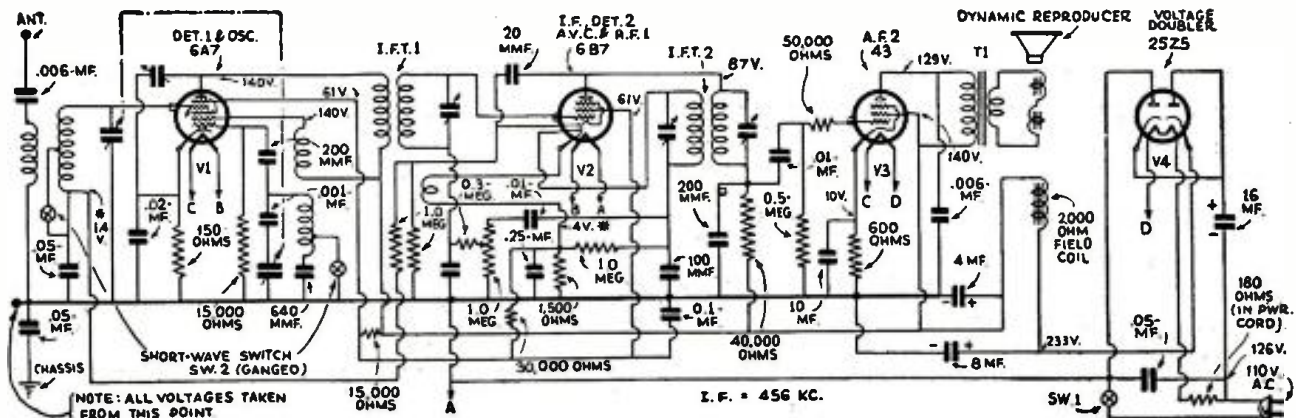



## OPERATING NOTES

(Continued from page 222)

After this procedure the sets in question all checked physically and electrically O.K. and were aligned. However, howling and circuit oscillation still were present. It was noted that when the variable condenser gang was moved toward the R.F. tube (see Fig. 3, A and B) the howling occurred and this gave a hint as to the trouble. The R.F. tube is next to the oscillator section of the gang condenser and when the two are too close feedback evidently occurs and builds up from an audio howl first started by feedback.

The R.F. tube is very inadequately shielded by a small projection from the lower side of the section shielding cover. Remove this small vertical piece of metal and install a regular tube shield over the 35 R.F. tube as per Fig. 3, A and B. Drill out 2 of the 4 rivets holding the R.F. socket to the chassis, and the new tube shield can be bolted down at 2 points. This procedure completely and finally eliminated all howls and oscillation. Be sure to realign the circuits after the shield is in place as it may slightly affect the trimming settings.

(Note that the service procedure in locating defective condensers—Fada KW—did not "clear" the trouble. A resistance test for leakage is recommended on small (bypass) condensers. —EDITOR)

### EDISON R-4

SET had no or partial volume, faded, cut out completely at times. All electrical values, voltages and currents were O.K. After an hour's listening I went to another call but 3 days later the same complaint was received. Three new tubes were needed and had been left at the first call and now a complete set was temporarily installed to eliminate tubes as a possible source of trouble. The complaint was repeated a few days later and I then watched the set for an hour steady and finally noted a flicker in the first A.F. tube heater brilliancy. Banging the chassis or the 27 1st A.F. (see Fig. 4) tube would sometimes gradually dim the brilliancy of this tube and the signal would of course go out as the heater dimmed. The chassis was "pulled," and the source of all fading and cutoff effects was found to lie in a poorly-soldered filament contact at the 27 1st A.F. socket terminals.

JOHN MUEHLKE

### STEINITE 421 and 425 (Model 21 Chassis)

RECENTLY had occasion to service a model 21 chassis united in Steinite 421 and 425 receivers. Test showed that the screen-grid tubes were receiving no screen-grid voltage, and one end of the bleeder resistor was quite warm; this indicated a short-circuit. The tubular .1-mf. bypass condensers were suspected. Tests showed 3 of them to be shorted. Replacement of these condensers restored normal reception.

JAMES L. HOARD

### A.K. 188, 260, 448, 469 and 489

POOR tone in Atwater Kent receiver models 188, 260, 448, 469 and 489 can very often be traced to the volume control; at the same time, the poor tone will be more pronounced on low volume. The resistance of this control should be .5-meg. Upon examination of the defective control it will be found to have increased to about 1. megohm. Replace this unit.

DAVID SQUIRES

### PEERLESS, SERIES 20, ELECTROSTATIC

RECEPTION intermittent—plays for hours, then cuts off. When checking for resistance, everything will read O.K.; when checking for voltage, it will immediately come up to normal and all voltages check O.K. The correction is to replace the condenser that is connected from the detector grid coil to ground.

JOHN NAUMANN AND GILBERT BECKER

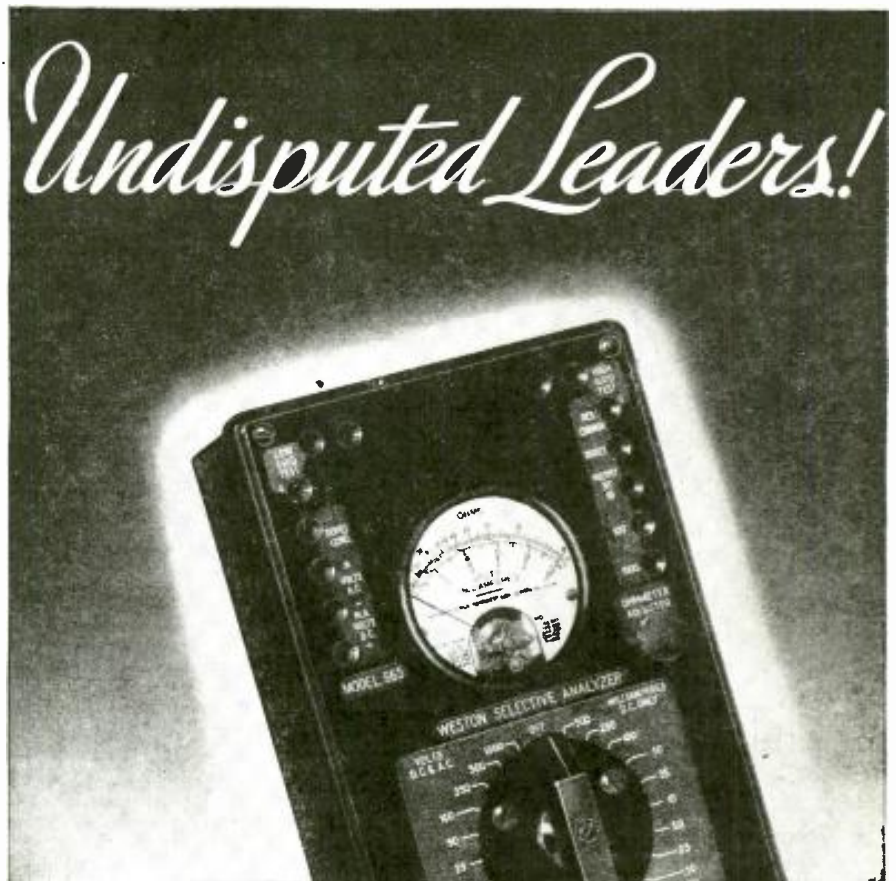

# WESTON

## Standardized Service Units

The aggressive service man recognizes that good instruments are business builders. With such instruments he can quickly and surely get at the root of the trouble... do a thorough job in shorter time. This builds confidence... and holds trade. And the good instrument is a *permanent* partner in his business... for it defies obsolescence, remaining dependable and serviceable throughout the years. In the field of portable test instruments, Weston Standardized Service Units hold undisputed leadership. They represent, by far, the greatest value ever offered in the servicing field. Weston Standardized Service Units consist of Model 663 Volt-Ohmmeter... Model 664 Capacity Meter... Model 665 Selective Analyzer and Model 694 Test Oscillator. Return the coupon for complete details... Weston Electrical Instrument Corporation, 599 Frelinghuysen Avenue, Newark, New Jersey.



# WESTON

Radio Instruments



WESTON ELECTRICAL INSTRUMENT CORPORATION  
599 Frelinghuysen Avenue, Newark, N. J.  
Send bulletin on Weston Radio Instruments.

Name \_\_\_\_\_

Address \_\_\_\_\_

City and State \_\_\_\_\_



The boys on the service benches all over the land are "eatin' 'em up." No wonder . . . for CENTRALAB Replacement Controls are doing a keen job . . . and (ahem) in many cases making the original old-fashioned control look like six cents in comparison. For these replacement units represent the last word in Volume Control efficiency.



The CENTRALAB patented non-rubbing contact eliminates wear and insures both mechanical and electrical smoothness of operation.

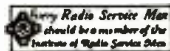

CENTRAL RADIO LABORATORIES MILWAUKEE

**Centralab**  
CENTRAL RADIO LABORATORIES  
MOTOR RADIO NOISE SUPPRESSORS

RADIO AMPLIFIER LABORATORIES

are manufacturers of

Complete PUBLIC ADDRESS SYSTEMS

and Associated Equipment  
Send 3c stamp for catalog

Radio Amplifier Laboratories  
291 E. 137 St. New York, N. Y.

## SUPER-SHORT WAVES

(Continued from page 213)

### Modulation Without "Side Bands"

Of far-reaching importance is the new system of electrical modulation (the method used to impress speech or other sounds on the carrier wave of a transmitter), which assures the practical utilization of centimeter-length waves by making it possible for the first time to control the amplitude or volume of the transmissions without producing "side bands"—that is, changing their frequency or wavelength. (In other words, if some such method were applied to the present, 200 to 550 meter broadcast band, it would not be necessary to limit stations to a "10 kc. band"—the number of stations that then could be operated in this range would be limited only by the selectivity of the receiver, and if the receiver could be made "1 kc. selective," for instance, 10 stations could be operated without cross-talk arising where now only 1 can be operated.)

An ordinary, mercury-and-argon tube of the kind used in the well-known luminous blue electric light displays (often erroneously referred to as "neon," the characteristic color of which, however, is almost red) is placed in the path of the centimeter-wave radiations to create a miniature man-made "Heaviside layer" controlling the intensity of the wave.

The natural Heaviside and Appleton layers, which are located about 75 miles above the surface of the earth, are responsible for the fading and skip-distance effects produced on longer wavelengths. Recent research has shown that the effects produced by the natural Heaviside layer are due to ionization (electrification of air molecules) of the gases in the upper atmosphere. With the new system of modulation, an extremely concentrated ionization is produced in the luminous tube, which duplicates the effects of the natural Heaviside layer in bending and absorbing the waves, but under controllable conditions. The principal advantage of this new type of modulation is that the wavelength is not affected by the modulation as it would be by all other known methods. A schematic representation of the manner in which modulation is achieved is shown in Fig. 2.

As is well known, wavelengths as low as 17 centimeters have been used successfully for communication across the English Channel, and continuous (non-modulated) waves of as low as 1 centimeter have been produced in the laboratory by Professor Williams at the University of Michigan, these 1 centimeter waves, however, having a very small power output. The experiments by the writers, on the other hand, were made at relatively high power levels; and, although undertaken at about 10 centimeters, are reproducible at lower wavelengths merely by a reduction in the size of the equipment.

### The Magnetron Transmitting Tube

A fundamental unit in the production of these "4 inch" radio waves is a special "magnetron" transmitting tube. This tube, although essentially the "split anode" magnetron of Okabe, has been greatly improved until now it is an extremely stable device, with high power-handling capacity. The completed tube is descriptively designated as the "end-plate" magnetron, and is shown by diagram in Fig. 3. The capacity between the two semi-cylindrical plates or anodes (a cylindrical plate cut in half), and the wiring around the bar circuit constitute the oscillatory circuit. The "end plate" serves to establish (at a critical value) an electrostatic field that draws the electrons from the filament and thus prevents space-charge effects; this results in greatly increased power output.

In order to generate oscillations by means of the magnetron, the plate potential and magnetic field must be adjusted so that electrons which leave the filament are deflected by the magnetic field until they barely graze the plate. With this adjustment it has been found that the tube has a negative-resistance characteristic which encourages the generation of oscillations at the natural frequency of any circuit which is attached to it.

The maintenance of these oscillations is considerably more dependent upon the constancy of the supply voltages, than it is upon the constants of the oscillatory circuit with which the tube is associated.

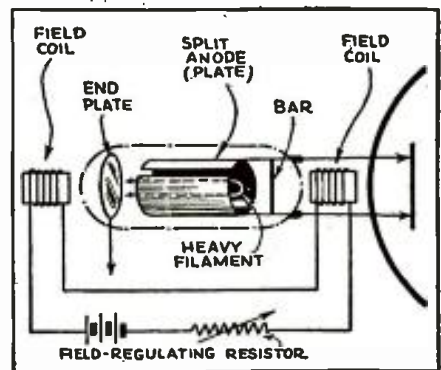

Fig. 1

The "end-plate" magnetron tube.

The transmission and radiation systems merely consist of a dipole antenna in the focus of a parabolic reflector, as shown in Fig. 1. The length of the transmission line must be adjusted to correspond to the wavelength being generated, the distance from the shorting bar, which is adjacent to the plates, to the antenna being a multiple of a half-wavelength.

### Methods of A. F. Modulation

Although the end-plate magnetron may be modulated on either the end plate or the semi-cylindrical plates, by placing the secondary of a transformer in series with the supply voltage, as shown at A in Fig. 1, a certain amount of frequency modulation (which thus produces "side-bands") results. The use of a variable-density ion (electron) screen overcomes this fault.

The ion-screen modulating device consists merely of a gas discharge tube which is placed in the path of the wave, as shown in the heading illustration and in Fig. A. As the current through this discharge tube is changed, the ion density varies, resulting in a variation of the index of refraction and absorption for the super-short radio waves. Sufficient voltage to maintain a discharge continuously is supplied from a rectifier unit, as shown in Fig. 2. In series with this D.C. supply is the secondary of a transformer, the primary of which is attached to a modulating source, such as a microphone.

Modulation is obtained either by permitting the radio waves to pass through the tube, or by using the tube as a reflector; in the former case the modulation is by absorption, and in the latter it is largely by refraction.

### The Receiver

Although a crystal detector may be used, the triode tube connected as a grid-leak detector is more stable in operation. Of the crystals, iron pyrites is the most efficient; the finest (sharpest) possible contact must be used.

The most powerful detector so far developed is the end-plate magnetron. Maximum sensitivity is obtained when the electron rotation period is equal to that of the impressed field; this condition is obtained by adjustment of the field coil strength. The R.F. is symmetrically applied to the two semi-cylindrical plates (or anodes). The resulting A.F. is obtained by connecting the primary of a transformer in the circuit of the leads which supply the two plates (or anodes) in parallel, as shown at B in Fig. 3. The detecting action is obtained by adjustment of the plate current potential characteristic for curvature at the bottom or (preferably) top.

Developments in recent years have unmistakably indicated to engineers that exploration in the field of extremely short waves will open up a vast number of additional usable radio channels for communication and other purposes (for instance, the remote control of various devices).

### Conclusion

Needless to add that without the improvement or development of the "magnetron" tube, the production of these "super" short waves would be practically impossible. Tests are being continued in this direction, and present indications are that much smaller waves can be generated—at high power levels.

## TUBELESS P.A. SYSTEM

(Continued from page 209)

City. Strange as it may seem, the system works well and supplies sufficient volume to be heard many feet from the signaling rooms on the station platforms.

The circuit of one of the units is shown at Fig. 1. The current is obtained from a 16 V. storage battery which feeds both the 2 button microphone and the speaker. The microphone is coupled to the line through a step-up transformer which boosts the voltage. A switch connects the mike to the line when it is desired to talk, and ordinarily the speaker is connected at all times so that all messages carried on the line are heard, regardless of what station or dispatch room they are intended for. Over 23 miles of lines are used and 60 speakers are coupled together over this circuit in the Interborough Rapid Transit installation.

The advantage of this system for dispatch work over telephone lines is in the fact that no operators are needed to connect lines and all dispatch offices are connected in case of an emergency. If an accident occurs, the dispatcher can instantaneously signal anyone at any one of the 60 speakers so that the power may be shut off or aid rushed to the scene.

The simplicity of the system suggests it as an interesting field for the radio fan. All that is needed is a carbon mike, a mike transformer with a high step-up ratio, a sensitive magnetic speaker and a source of potential, such as a storage battery or a battery of dry cells.

## INTERNATIONAL RADIO REVIEW

(Continued from page 211)

small rectangular cabinet which may be placed on top of the radio set or on any convenient table. The cabinet is opened by pulling down the front cover which automatically sets the turn table for use as shown in Fig. B. The latter is mounted on a shelf in the cabinet which moves forward as the front is dropped down for easy accessibility.

## HOW EUROPEAN BROADCASTING STANDS

**A**N ISSUE of WIRELESS WORLD a short time ago published an interesting chart showing the latest official license figures for radio listeners in all of the major European countries. Listeners from practically every country in Europe pay a fee for their entertainment. A census of these license figures is, thus, a good indication of the number of listeners in any country. The chart, Fig. 5, shows the number of these licensed radio sets as well as the number of additions during 1933.

The remarkable effect which broadcasting can have over every European country is obvious from the magnitude of these figures. On the widely accepted assumption that each license (radio set) represents at least four listeners, there are now approximately 71,500,000 listeners.

Fig. 7

An improved tone control circuit.

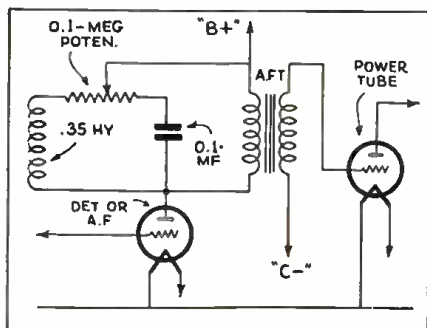

# TOP O' THE WAVE OF SUCCESS!

FROM the Arctics to the Tropics—East to West—in forty countries—on airplanes, naval craft, automobiles and police cars—in long-distance amateur sets and rich-toned home radios—in the initial equipment of 60% of the country's licensed radio-set manufacturers . . . millions of Raytheon 4-pillar Tubes are used.

Sheer quality is the outstanding reason why Raytheons are so widely chosen. More than 95 minute pieces of wire, metal and chemicals are processed with microscopic accuracy into the assemblage of Raytheon 4-pillar Tubes—giving to them an unrivaled sensitiveness and a fixed and accurate balance. 4-pillar element support provides a matchless sturdiness that defies jolts and vibration and makes Raytheon a decided favorite, particularly where dependability and long life are important considerations.

Twenty thousand dealers sell Raytheons, the only radio tubes with a distinctive and exclusive feature: 4-pillar construction. Try them and NOTE THE DIFFERENCE.

RAYTHEON PRODUCTION CORPORATION

**RAYTHEON**  
TRADE-MARK  
**4-PILLAR RADIO TUBES**

30 East 42nd Street  
New York City  
55 Chapel Street  
Newton, Mass.  
445 Lake Shore Drive  
Chicago  
555 Howard Street  
San Francisco

# Train Now for New RADIO Opportunities



**Get Into a Line Where There's Action—Every Day—And a Payday Every Week—You Be the Boss!**

**Analyzer & Resistance Tester—Latest Design—YOURS Without Extra Cost**

Right now while hundreds are looking for work where there isn't any, the radio service field can use trained men. With the proper training and the necessary equipment, you can enter this field and make a comfortable living. We include with our course this modern set analyzer and trouble shooter without any extra charge. This piece of equipment has proved to be a valuable help to our members. After a brief period of training, you can take the set analyzer out on service calls and really compete with "old timers." We show you how to wire short-wave receivers—analyze and repair all types of radio sets—and many other profitable jobs can be yours. Teaching you this interesting work is our business and we have provided ourselves with every facility to help you learn quickly yet thoroughly. If you possess average intelligence and the desire to make real progress on your own merits, you will be interested.

## ACT NOW—MAIL COUPON

Start this very minute! Send for full details of our plan and free booklet that explains how easily you can now cash in on radio quickly. Don't put it off! Write today. **SEND NOW!**

**RADIO TRAINING ASSN. of AMERICA**  
Dept. R-10, 4513 Ravenswood Ave., Chicago, Ill.  
Gentlemen: Send me details of your Enrollment Plan and information on how to learn to make real money in radio quick.

Name .....

Address .....

City..... State.....

*Dependable Sensational Performance!*

## BUD

Laboratory-Built P. A. Equipment

**5 DAYS FREE Trial**

Try **BUD** Sound Equipment For Five Days Absolutely Free!

PORTABLE SOUND SYSTEMS  
ELECTRO-DYNAMIC UNITS  
CARBON AND CONDENSER  
MICROPHONES - 4 & 6 FT.  
ALL ALUMINUM TRUMPETS  
FIELD EXCITERS - AIR COLUMN  
HORNS - LOW AND HIGH  
FREQUENCY UNITS FOR WIDE  
RANGE THEATRE USE

We invite careful, critical inspection of our entire line of **BUD** laboratory-built sound equipment. We suggest that you conduct your own comparative test. We CHALLENGE you to duplicate **BUD** performance and **BUD** dependability at any price! Write today for descriptive literature and prices and details of our **FREE FIVE DAY TRIAL** offer.

**BUD SPEAKER CO.**  
1120 JACKSON ST.  
TOLEDO, OHIO—U. S. A.

**SOLAR** ★

WET AND DRY ELECTROLYTIC PAPER AND MICA CONDENSERS

RECOGNIZED FOR SUPERIOR QUALITY IN ALL CLIMATES THE WORLD OVER

ASK FOR CATALOG OF EXTREMELY COMPACT TYPES HANDY FOR SERVICE

**BEST BY TEST!**

SOLAR MFG. CORP.  
399 BROADWAY  
NEW YORK

in the listed countries alone. Other European countries not included in the chart account for approximately one half million additional listeners. In the case of France, the license system did not exist prior to 1933, which accounts for the entire list being included in new licenses.

According to **WIRELESS WORLD**, the record percentage gain in a year was achieved by Palestine, with 155.5 per cent increase, bringing the total to 2500. The lowest recorded license figure is that of Levant, i.e., 785. Italy's comparatively low figure is ascribed to "piracy" and also to the climate. Apparently radio set manufacturers have not cashed in on the national love of open-air life by pushing portable set sales, there.

## A DUAL-SPEAKER UNIT

THE RECENT advances in tone quality requirements of receivers and amplifier systems have brought forth a response from manufacturers in the form of "Tweeter" horns and small dynamic units for increasing the high frequency tones in either single or dual channel amplifiers. One answer to the problem has been the introduction on European markets of dual speaker units containing two complete dynamic reproducers with a single output coupling transformer circuit. These speaker units, shown in Fig. C, are matched so that a fairly constant sound output is obtained over the audible range from 60 to 10,000 cycles.

One advantage of a combination of speakers of this type which are manufactured as a unit is the fact that the field coil resistances can be so adjusted that the complete resistance with the two coils in series is the correct value for the particular circuit in which they are to be used. Also, the impedance relations can be adjusted so that each speaker receives the desired field excitation.

## AN ITALIAN ONE TUBER

AS WE have mentioned before on this page, American tubes are used extensively in certain European countries, one of the most prominent being Italy.

In Fig. 6 is shown a circuit which has been developed around a tube similar in design and construction to the 2A7. The only difference in the two tubes is in filament characteristics. This set is a one tube "reflex" which shows much promise for the radio set constructor and experimenter. It appeared in a recent issue of **LA RADIO PER TUTTI**. An examination of the circuit shows that the signal is tuned by coil L1 and one section of the 350 mmf. tuning condenser. It is then fed into the control-grid of the pentode section of the tube, after which a second tuning circuit, L2 and the second section of the tuning condenser, increases the selectivity and serves to feed the signal into the grid of the triode section of the tube. Here it is rectified and passed on to the headphones.

The values of all the parts required for this set are indicated on the schematic circuit. Instead of the 2T7 tube, one of the available 2A7s can be utilized. The coils L1 and L2 may be any well designed T.R.F. coils which cover the broadcast band when tuned by a 350 mmf. condenser.

For those who are not familiar with the action of the 2A7 tube we would suggest a review of several past issues of **RADIO-CRAFT**, notably the July 1933 issue, page 14.

Fig. 8

An improved resonance indicator.

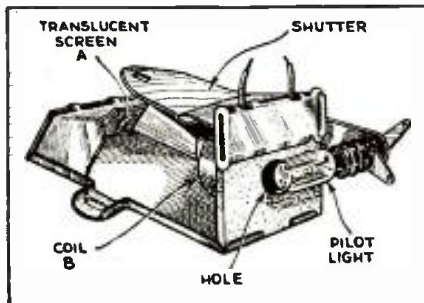

## AN IMPROVED TONE CONTROL

THE TONE control systems employed in most receivers consist of a condenser of appropriate size connected in series with a variable resistor. By varying the value of resistance, the effective attenuation of the high tones can be controlled. However, this type of tone control does not permit the operator to accentuate the high notes but simply makes the base tones predominate by reducing the strength of the "highs."

A tone control which not only accentuates the base notes but also permits high frequency signals to be brought out strongly, at the will of the operator, was described recently in **AMATEUR WIRELESS**. It consists of a choke coil, a condenser, and a potentiometer all connected in series and the combination in turn connected across the primary of one of the A.F. transformers. The choke coil has an inductance of about .3 to .4 henry; the potentiometer has a resistance of 100,000 ohms and the condenser has a capacity of .1-mf. By moving the potentiometer arm from one end to the other it is possible to completely eliminate either the very high or the very low tones, while if it is in the center of its excursion, the characteristics of the amplifier are not affected. The connections for this tone control system are shown in Fig. 7.

## A SHADOW TUNING INDICATOR

IN A recent issue of **WIRELESS WORLD**, a new form of shadow tuning indicator which has made its appearance on the English market, was described. A sketch of this device appears in Fig. 8. While it is similar in design to American units for the same purpose, it varies considerably in mechanical construction. The light from a pilot bulb passes through a small hole in the back of the indicator and is projected against a translucent screen, A, which is fully illuminated when no signal is being received. A shutter consisting of an electromagnet connected in the plate circuit of the R.F. or I.F. tubes and a pivoted vane intercepts the light when a signal is received so that a shadow is cast on the translucent screen A. The position of the vane, B, depends on the strength of the signal being received and thus indicates resonance.

It is interesting to note that, in addition to the meter type indicator described above and the neon light beam indicators, a miniature cathode ray tube is also available in England for use as a tuning indicator. We described this instrument some time ago. (**RADIO-CRAFT**, March 1934, page 527.)

The shadow tuning indicator is by no means a new device in this country. As a matter of fact, several manufactured receivers employed such a visual tuning indicator (for resonance indication) several years ago. The construction probably differs greatly, in this particular device, from the American made units—which is our reason for describing it.

## THE MARIMBALITE

(Continued from page 205)

- Drafting Musical Compositions, by Otto Kappel-mayer  
September, 1932, page 192B.
- Electromagnetic Music, by Carl Dobesch  
November, 1932, page 271.
- How to Build the Trautonium Musical Instrument, by Clifford E. Denton  
March, 1933, page 522.
- More Information on the Trautonium, by Fritz Noack  
April, 1933, page 590.
- And Now—The Electric Violin  
August, 1933, page 85.
- A Telepiano  
January, 1934, page 402.
- How to Make the Beginner's Pianotron, by F. R. Harris  
January, 1934, page 414.
- A Neon Type Electro-Musical "Trombone," by Melchor Centeno V.  
March, 1934, page 525.
- The "Polytone," by F. M. Sammis  
May, 1934, page 657.
- The "Syntronic" Organ, by E. E. Kassel  
August, 1934, page 77.

# ALL WAVE OSCILLATOR FREE!

**DIRECT READING ON FUNDAMENTALS . . . not Harmonics . . . Full Frequency Coverage . . . Range 14 to 3000 meters (100 to 21,600 K. C.) . . . Absolute Attenuation at Highest Frequencies . . . Frequency Stability Assured . . . Extreme Accuracy . . . Dial Permits Accurate Readings to 1-10th of 1% . . . Compact . . . Approved by National Union Engineers . . . an Absolute Necessity for Modern All Wave Set Servicing . . . FREE with National Union tube purchases. Small deposit. Get Details!**

## SERVICE DEALERS!

Let National Union help you to *greater profits* through (1). **FREE SHOP EQUIPMENT:** Testers, Analyzers, Manuals, and Service Tools given with National Union tube purchases. (2). **SERVICE AIDS:** Charts, Data information at no cost. (3). **SUPERIOR QUALITY:** Strict adherence to closer manufacturing limits gives National Union tubes consistent superiority. (4). **TEN CENT HIGHER LIST PRICES:** Highest profit margin on all tube sales. (5). **MAINTAINED LIST:** No fear of customer ill will caused by seeing tubes in cut price stores. *No service dealer can afford not to tie up with the National Union program for service profits.*



Clay Millican, Independence, Kansas says: "National Union . . . a reliable company . . . a fine tube . . . working for interest of the serviceman . . ."

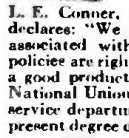

L. E. Conner, Seattle, Wash. declares: "We are proud to be associated with a firm whose policies are right and who build a good product . . . We thank National Union for helping our service department acquire it's present degree of efficiency . . ."



W. L. Hollenback, Altoona, Pa. writes: "National Union interesting to servicemen because of free equipment . . . quality tubes . . . free educational and advertising material . . ."

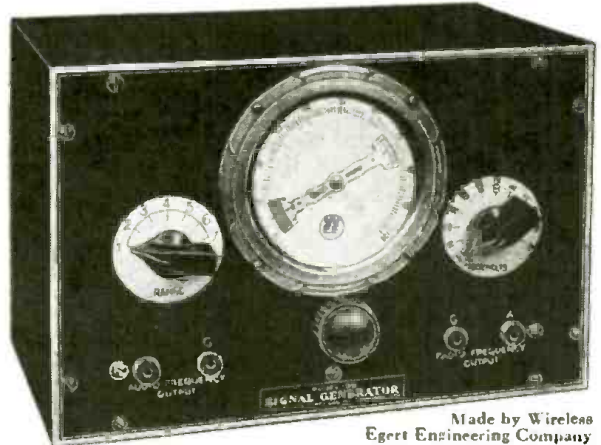

Made by Wireless Eger Engineering Company

National Union Radio Corporation of N. Y.  
400 Madison Avenue,  
New York City.



Tell me more about . . . . .

Name . . . . .

Street . . . . .

City . . . . . State . . . . .

## A 2 TUBE CONVERTER

(Continued from page 223)

range is covered by this coil assembly, whereas most short-wave converters, particularly those that employ plug-in coils, generally cover only 2 wave-bands in the short-wave spectrum. By covering this complete range of higher frequencies, the listener-in can tune to the S.-W. broadcast programs, police calls, aviation calls, or amateur phone or C.W. signals, or as a matter of fact anything that is being broadcast between the wavelength range of 16 to 200 meters.

This converter can be connected to any regular broadcast receiver, whether of the T.R.F. or Superhet. type is immaterial, and because of the inclusion of a power supply unit in its design—is independent of the receiver for filament and plate voltages. Also, it will operate from either 110 V. A.C. or 110 V. D.C., and since no transformer is employed in its construction very little service trouble from excessive power voltage (i.e., normal power fluctuations) will ever be encountered.

### Only 2 Tubes Used

Only 2 tubes are used in the entire unit, a 6A7—which is a composite tube (2 tubes in 1 envelope) and which functions as a detector and oscillator, and a 25Z5—which is a rectifier and functions as a half-wave device in this particular converter. An approximate idea of the layout of parts can be obtained from the photographs of the unit shown. For convenience sake the switch and coil assembly was mounted on the left, looking straight on at the converter, the variable condenser in the center, volume control on the lower right, and power switch on the lower left. All wiring is performed on the under side of the chassis base—to add to the appearance of the unit.

An airplane-type tuning dial is employed for further enhancing the appearance of the converter. Close inspection will reveal that this

control is not the conventional type of tuning dial, but uses, instead of an ordinary arrow indicator, a special type of indicator that has additional scale divisions which permit tuning to such a "fine" extent that each degree on the major scale can be "broken up" to tenths. This is indeed an asset in short-wave tuning, as many short-wave enthusiasts can attest to, since it is most essential that a very careful and deliberate tuning procedure be employed if complete reception is desired.

### Connecting the Converter

When connecting up this converter to the broadcast receiver, either the output from this unit can be obtained from the primary terminals of the tuned transformer (as indicated on the diagram, Fig. 1), or by employing the third terminal marked "output" and which connects to the plate of the output section of the 6A7 tube through a .001-mf. condenser. However, for greatest selectivity the first arrangement would be best. It should of course be understood that the output of this converter must be connected to the antenna and ground terminals of the receiver, and the antenna and ground proper connected to the converter.

The unit employs its own volume control, but it is possible, if desired, to employ the volume control on the receiver. Also, when tuning for stations, it is advisable to first select or place the tuning dial of the receiver in a position where, generally, stations are obtained efficiently, since in a good many receivers the amplification (R.F.) may vary considerably from one end of the dial to the other.

This item is not only a valuable asset to the broadcast listener in that it will open up a new and exceedingly fascinating realm of distinctly different programs—but should also interest the Service Man, since it offers him an attractive item that he can easily introduce to his customers, and thereby with little effort augment his regular income obtained through servicing receivers.

### List of Parts

- One Try-Mo punched and drilled chassis;
- One micro vernier (airplane type) dial;
- One Powertest output coil assembly;
- One Powertest filter choke;
- One Hammarlund 140 mmf. variable condenser;
- One 6A7 wafer socket;
- One 25Z5 wafer socket;
- Three knobs;
- One Naald switch coil assembly;
- One .01 mf. condenser, 200 V.;
- One Centralab 50,000 ohm potentiometer;
- Two Concourse .1 condensers, 200 V.;
- One Aerovox dual 8 mf. condenser, 200 V.;
- One 100 mmf. mica condenser;
- One Triple output binding post strip;
- One Electrad 250 ohm, 20 W. resistor;
- One Electrad 400 ohm, 1 W. resistor;
- One Electrad 8000 ohm, 1 W. resistor;
- One Electrad 10,000 ohm, 1 W. resistor;
- One Electrad 25,000 ohm, 1 W. resistor;
- One Powertest line cord;
- One Powertest "on-off" switch;
- One Hammarlund or Naald set of 4 plug-in coils;
- One tube shield.

Underside view of short-wave converter.

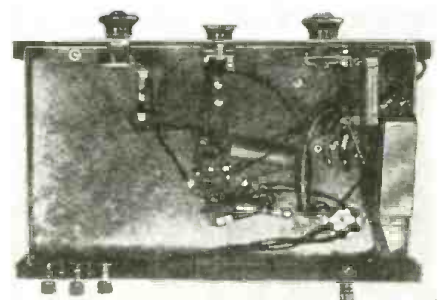

**RCA makes  
aerial history!**

**NEW  
ALL WAVE ANTENNA**

"Provides a new source of profit for the wide-awake service man"—says A. H. Prow, Pres. Phila. Radio Service Men's Association.

EVERY home with an all wave set is an immediate prospect... so get busy! Tell your customers how this remarkable new antenna brings up weak signals, cuts down man-made interference, gives more uniform response because of special "double doubler" feature. Kit of essential parts retails for \$6.00. Your installation charge extra.

Special "Dealer Demonstration" Antenna Kit, Net Price \$9.85, makes possible convincing demonstrations in your store. Connects to four receivers.

Have you seen the remarkable new RCA Full Range Test Oscillator? 90 to 25,000 K. C. Direct Reading Dial, weighs 5 pounds with batteries. Only \$29.50

Write RCA Parts Division, Camden, N. J.



**LITTLE DYNAMITE**

A POWERFUL high quality amplifier yet extremely compact in size (measuring 5 x 5 x 6" high). Has excellent response over the audio band. Especially suitable for small or portable P.A. Systems for recording and for use in conjunction with photo cells, etc. Uses a 57 high gain pentode and the dual triode 2B6 tube. An 80 tube provides humless plate supply. Overall gain 40.5 db. Will supply 1-1000 ohm field. Output 5 watts. List price, less tubes \$22.50. Dealer's net price



**\$8.95**

Three Arcturus Tubes net \$3.15.

Write in for free Alan Sound Handbook off the press soon.

**ALAN RADIO CORP.**

83-R Cortlandt Street New York, N. Y.

**You Should Have  
The New ELECTRAD  
1934-35 CATALOG**

Every radio manufacturer, engineer, dealer, service man and experimenter should have this veritable encyclopaedia of useful resistor information—FREE.

Write Dept. "RC-10"

175 Varick St., New York, N.Y.

**ELECTRAD**

## A MIDGET TESTER

(Continued from page 223)

made with this instrument in any electrical circuit up to 1000 ma. only.

Resistance: A very wide range of A.C. and D.C. resistance measurements make it possible to determine the value of any resistor employed in commercial radio sets and most all other electrical apparatus.

The inductance measurements provide facilities for making reasonably accurate comparisons of transformers, chokes, and similar equipment.

The capacity of any condenser within the range of this instrument can be determined as easily as measuring resistance, voltage, and current. One of the outstanding features of this tester is the measurement of electrolytic condenser capacity and is extremely important due to the extensive use of this type of condenser in modern radio sets and other electrical apparatus.

### Instructions for Operation

#### Voltage and Current

In the operation of an instrument of this type, it is important that care be taken to set the switches correctly. Damage may be done in attempting to read D.C. values when A.C. is employed. Likewise, damage will result if the instrument is set as an ammeter and is connected across a potential source as a voltmeter.

When starting to make measurements of current or voltage, set the range selector switch on the tester to the 1000 ma. or 1000 V. position, and set the A.C.-D.C. switch to the desired position.

If a reading is obtained with the instrument set in this manner, the range is 1000 ma. or V., as the case may be. If the instrument is adjusted for D.C. volts and the deflection is not too great, the range selector switch should be turned to the 250 V. range. If the deflection is still small, turn the range selector switch first to the 100 V. range then to the 25 V. range, and then to the 5 V. range or until a large deflection is recorded. On the other hand, if the current is being measured first, set the range selector switch to 1000, 100, 10 and 1 ma., respectively.

When the A.C.-D.C. switch is set to A.C., only A.C. voltages may be measured. Therefore, do not attempt to make A.C. current measurements.

#### D.C. Resistance

To measure D.C. resistance up to 50,000 ohms, set the A.C.-D.C. switch to D.C. and the range selector switch to R. Then connect a short across the terminals of the instrument and obtain zero adjustment by turning ohmmeter adjuster to the right or left until full-scale deflection is obtained. Remove the short and connect the "unknown" resistor across the terminals.

The value of the unknown resistance may be obtained by reading the resistance scale and multiplying by the scale factor. If all buttons are up, the scale factor is 10; if button 1 is depressed the scale factor is 1.

For resistance measurements of 50,000 to 5 megs., the procedure is a little different.

The instrument is connected to 110 V., A.C. and the range selector switch set to Z. The A.C.-D.C. switch is set to D.C. and button 10,000 is depressed. Zero adjustment is made by shorting the terminals and turning the A.C. line adjuster until zero resistance is read. Then remove the short and place the resistor across the terminals of the unit. The resistance value then indicated will be the resistance value shown on the scale multiplied by 10,000.

#### A.C. Impedance

Impedance may be capacitive, inductive or resistive. When the impedance to be measured is resistive, the value of this resistance may be determined by setting the A.C.-D.C. switch to A.C. and the selector switch to Z, then the meter is plugged into 110 V. A.C. Zero is adjusted by placing a short, similar for "ohms test." The "unknown" resistor is placed across the terminals of the meter. The meter reading is then referred to the auxiliary scale. If no

buttons are depressed, the unknown resistance will be the scale reading multiplied by 100. If the 10 button is depressed multiply the resistance reading by 10; if button 1 is depressed the resistance will be directly as indicated.

#### Inductance and Capacity

When the impedance is composed of inductance or capacity, the inductance or capacity may be determined by setting the A.C.-D.C. switch to A.C. and the selector switch to Z. Plug the meter into 110 V. A.C. The meter terminals should then be shorted and zero adjustment made. The short is removed and the unknown capacity or inductance placed across the terminals of the tester and the scale read.

#### Inductance

Refer reading to the auxiliary scale and if no buttons are depressed multiply the inductance reading by 100. If button 10 is depressed, multiply the inductance reading by 10. If button 1 is depressed the unknown inductance will be directly as indicated.

#### Capacity

If no buttons are depressed divide the meter reading by a scale factor of 100. If button 10 is depressed divide by a scale factor of 10. If button 1 is depressed, scale is read direct.

#### Electrolytic Condensers

When testing electrolytic condensers, it is desirable to know both the amount of leakage and the capacity. As a result, two separate tests are required. In either case, the instrument is connected to 110 V. A.C. and the range selector switch set to Z.

When testing leakage, the A.C.-D.C. switch is set to D.C. and button 10,000 is depressed. Zero adjustment is made by shorting terminals and turning the A.C. line adjuster until zero resistance is read. Then remove the short and place the condenser across the terminals of the tester, connecting the positive lead of the electrolytic condenser to the positive terminal of the instrument. Leakage resistance will then be the resistance scale reading, times 10,000.

To measure capacity, measurements are made exactly as in the case of an ordinary condenser.

#### LIST OF PARTS

- One Shallcross carrying case, 10x9½x5¼ ins.;
- One Shallcross type 611 engraved panel;
- One Shallcross resistor kit No. 611;
- One Shallcross universal meter No. 611;
- Two Shallcross 11 Point selector switches No. 1370;
- Two Shallcross fuse mountings No. 1407;
- One special transformer (such as Shallcross No. 2158 or general transformer No. 1063) and brackets;
- One plug and cord;
- Four special switches and parts (as indicated on diagram);
- One fixed condenser, 1 mfd.;
- One type 37 tube;
- One type 37 tube socket;
- Two pin jacks;
- Two fuses, 1/32-amp.;
- One potentiometer, 200 ohms;
- One flashlight battery.

The scale of the completed meter.

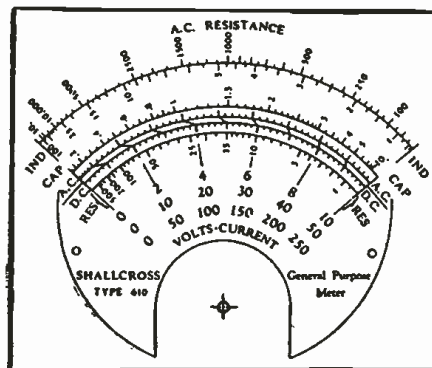

## 12 WAVE RADIOPHONE A HIGH-GAIN AMPLIFIER

(Continued from page 209)

(Continued from page 215)

a cheap and reliable method of effecting short-distance communication. This has been confirmed by an installation which was set up by the British Post Office 18 months ago across the Bristol Channel and which has been in daily use during this period as part of a trunk telephone circuit.

The receiver consists of a super-regenerative, high-frequency receiving stage, a volume indicator, an A.F. amplifier, and a 3,000 cycle low-pass filter. The transmitter consists of an A.F. amplifier, an oscillator, the output of which is modulated by speech currents, and rectifying equipment, since the transmitter is designed to work directly off an A.C. line.

The antenna is a simple half-wave horizontal oscillator. It has a thick portion in the center of the triatic slung between the tops of the 50 ft. wooden poles. The 4 wire circuit is completed by wire trunks to the respective exchanges.

Usually, however, more than one channel is required, i.e., it is necessary to accommodate several simultaneous conversations and this has to date been provided by multi-core submarine cables. In the radio case, such facilities involve either the use of one large transmitter, on the carrier frequency of which all the conversations can be superimposed, or several small transmitters all operated on different frequencies and each carrying a single conversation. The latter alternative has several advantages but presents several problems, the main one of which is mutual interference between various circuits.

To obtain data on these problems; arrangements have been made by the British Post Office to set up a 6 circuit equipment between Castleton, near Cardiff and Backwell Hill, near Bristol. For economic reasons it is most desirable that all equipment and aerial systems should be concentrated within a small area and, in order to provide information as to the maximum number of circuits which could be operated in any future installations, it is necessary that the frequency separation between the various transmitters should be as small as possible; although, of course, the closer the group of the aerials and the smaller the frequency separation, the greater is the risk of mutual interference. Actually the wavelengths used, 12 in all, are within 4 to 6 meters and the transmitting and receiving aerials are each grouped in a space measuring only 90 x 150 ft.

Wavelengths of this order do not appear to be reflected from the ionized upper layers of the atmosphere, thus making reception only possible from the directly propagated wave. One important result of this is the fact that there is no fading of signals. Also on these wavelengths, natural atmospheric are entirely absent, so that from the point of view of stability and freedom from noise, the radio path is equal to a good wire circuit.

Transmitter shack and antenna of Bristol radiotelephone.

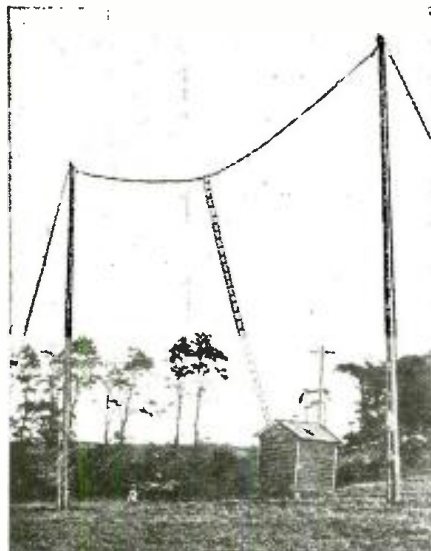

batteries can be used as the drain is very little.

Use the best parts obtainable. Make sure the push-pull output transformer is matched to 45's and can carry over 50 ma. in each half. The power transformer should deliver 375 to 420 V. on each half of the high voltage winding at 150 ma. without heating up too much. Use a speaker capable of handling 20 W. without rattling.

No trouble with hum was encountered, and in fact it is possible to place your ear right in the speaker and just hear the faintest hum. The first filter choke may be left out without increasing the hum appreciably. At full volume an external ground will reduce any objectionable noise.

This P.A. system was built with an aluminum front panel 14x20 ins. high, and all volume controls, speaker outlets, meter, etc. were mounted on it. This panel is of course not necessary, but it adds class to the amplifier and your customers will be impressed.

Don't be alarmed at what you may think are wrong resistance values. Regardless of theoretical tube data, this amplifier works. And how!!

### Hints on Operation

Use a large baffle board or horn on speaker. Place speaker in corner of hall if possible. Always test pickup and microphone before starting.

Always have extra tubes with you. Always have plenty of the latest records. Always have a long electric extension wire.

A needle that plays a thousand records is handy to have.

Make clean and neat installations so that you will get repeat business.

Display a sign with your name and address at all installations.

It is always advisable to carry a spare microphone, as well as microphone batteries for emergencies.

Test equipment just before it is to be used. This may save you a great deal of trouble and embarrassment should trouble develop just when the equipment is to be employed.

### List of Parts

One Alan 2:1 ratio A.F. transformer, T1;  
One class A prime input transformer, (see text for type) T2;

One Alan power transformer, T4;  
One 45 push-pull output transformer, T3;  
One 250 ohm choke, T5;

Two 25 mf., 25 V. electrolytic condensers, C1, C2;

One .5 mf., 200 V. electrolytic condenser, C3;  
One .05 mf., 300 V. electrolytic condenser, C4;  
Three 8 mf., 500 V. electrolytic condensers, C5, 6, 7;

One .25-meg. potentiometer, R1;  
One 1200 ohm 1 W. resistor, R2;  
One 5000 ohm 1 W. resistor, R3;  
One 50,000 ohm 1 W. resistor, R4;  
One .25-meg. 1 W. resistor, R5;  
One .5 meg. 1 W. resistor, R6;  
One 2700 ohm 1 W. resistor, R7;  
One Alan drilled and stamped chassis, 12x8½ x3 ins.;

One aluminum panel 14x20 ins. (optional);  
One Alan 6 prong socket;

One Alan 5 prong socket;  
Four Alan 4 prong sockets;

One Alan speaker socket and plug;  
One phono input terminal block;

One A.C. switch, plug and wire;  
One "C" battery 45 to 70 volts;

One 1000 ohm field dynamic speaker;  
One 57 tube;

One 56 tube;  
Three 45 tubes;

One 5Z3 tube;  
One high impedance phonograph pickup;

One double-button microphone;  
One microphone control box;

Extra wire, cable, etc.

### Control Box Parts

One 2 button mike transformer, T1;  
Two .25-meg. potentiometers, R1, R2;

One high impedance pickup, P;  
One 3 to 4½ V. battery.

## ANNOUNCING

Two NEW and BETTER Tube Testers!

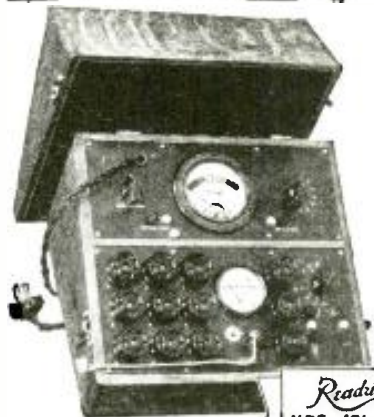

Readrite NOS. 421-422

**R** EADRITE announces two new and better tube testers: the No. 421, for the dealer's counter—and the No. 422, a portable unit for the service man . . . out in the field. These improved testers are characterized by many unusual and outstanding features that give a new conception of tube tester performance. They are so simply designed that anyone, without experience, can operate and understand them.

These testers incorporate a 3½" Triplett Precision Meter, which has a shaded two-color scale. It indicates in simple English that the condition of the tube is either "good" or "poor." No longer need you reassure skeptical customers as to the worth of tubes that you are testing for them.

A line voltage control A.C. Meter is incorporated. Cathode and grid shorts are also tested. A simple push button provides two-plate current readings for determining the worth and conductance of all types of new and old tubes.

### Your Jobber Can Supply You

. . . with the No. 421 (counter tester) at the dealer's net price of \$24.00—and with the No. 422 (portable tester), at the dealer's net price of \$25.50. These testers come in a beautiful quarter-sawed oak case.

### READRITE METER WORKS

127 College Ave. Bluffton, Ohio



## SEND COUPON FOR FACTS!

### READRITE METER WORKS,

127 College Ave.,  
Bluffton, Ohio

Gentlemen:

Send me a catalog on Readrite Tube Testers, and your complete line of radio servicing equipment.

Name .....

Address .....

City ..... State .....

# The **TOBE** Condenser Analyzer

**WILL SAVE YOU MONEY-TIME-TROUBLE-EMBARRASSMENT!**



● Take the guesswork out of condenser trouble-shooting. ● It's so simple to know definitely if condensers are **LEAKY**, of low **D.C. RESISTANCE** or **HIGH LEAKAGE CURRENT**, if they are operating **INTERMITTENTLY**, or if they are **"OPEN"** or **"SHORTED."** ●

● Let hundreds of testimonials like this one convince you that you need this instrument:

"The **TOBE CONDENSER ANALYZER**, which I received through the Radolek Co. of Chicago, is easily the most decisively efficient instrument I have and I have most of them. If I was starting to build up an outfit of testing instruments, I would buy the **ANALYZER** first."

Yours truly,

**FRED JEFFREY,**  
Martinsburg, Nebraska.

## Obtain a **TOBE** CONDENSER ANALYZER Today

from your Distributor or direct from the factory. (Allow postage on six pounds.)

Net Price to Serviceman or Dealer Only .....

**\$11.40**

Price \$11.70 in Denver and the West Coast

A COMPLETE CATALOG OF TOBE CONDENSER PRODUCTS SENT FREE ON REQUEST

**TOBE DEUTSCHMANN CORPORATION**  
CANTON, MASS.

## USES OF A NEON-TUBE CONDENSER ANALYZER

(Continued from page 214)

glow lamp.

Condensers ranging in capacity from .05 mfd. to approximately 50 micromicrofarads are tested with the leakage control set to position No. 1. In this case the circuit does not operate as a relaxation oscillator. However, charge and discharge as well as leakage currents are indicated.

On either setting of No. 1 or No. 2 of the leakage control "shorted" condensers will cause a steady bright red glow of the neon tube and "open" condensers will not allow the initial charging current to flash the neon tube.

Condensers of an intermittent nature when connected to the test circuit, will start out by causing a certain rate of flash of the neon glow lamp and after a few seconds of operation, due to an internal resistance change in the condenser, the rate of flash of the neon tube will change likewise. Frequently, the intermittent condenser will open while on test in which case the flashing of the neon will become interrupted. When the connection is made again internally, the flashing of the neon will continue.

Resistors R1, R2, and R3 are used only in testing condensers of the electrolytic type. Here the circuit functions mainly as an indicator of high leakage current in the test circuit.

Voltage, regulator, and leakage controls are set to the voltage rating and capacity of the condenser under test. Upon application of the condenser to the test clips of the instrument, a charging current will flow through the output circuit as well as through the resistors connected to the leakage control, causing an immediate glow of the neon lamp.

Superimposed on this charging current will also be the current due to the dielectric structure or D.C. resistance of the test condenser CX. The greater the leakage current flowing through the leakage control resistor, the greater will be the voltage across the resistor and consequently across the neon tube. As a result the neon tube will remain ignited until the leakage current flowing through CX falls to an acceptable value.

At this point, the voltage appearing across the resistor in parallel with the neon tube will fall below the striking voltage of the neon and the light will become extinguished. This indicates the condenser is "satisfactory" and may be continued or placed in service.

Too high a leakage current would cause the voltage across the neon tube to continue higher than the striking voltage in which case the neon would remain ignited continually.

Here again a short circuit condition would cause a bright red glow of the neon and an "open" condenser would not permit the initial charging flash nor the leakage current to strike the neon tube to the ignition point. No flashing of the neon tube, of course, will take place in testing the electrolytic type of condensers.

The circuit shown may be used with the leakage control set to position 2 for testing high resistances in the order of 100 to 5000 megohms, such as the resistance of cable insulation, the insulation used in transformers from winding to the case, the quality of the cables used in automobile engines for connections from spark coils to spark plugs, etc.

Switches S1 and S2 are controlled by the same tumbler. When switch S1 is closed, switch S2 is open. However, when switch S1 opens, switch S2 connects the plate of 01A tube to the filament. This operation discharges the test condenser and thus eliminates danger of shock to the operator.

Undoubtedly a great many uses will suggest themselves to the enterprising Service Man who uses this instrument.

## NEW RESISTORS

A new line of resistors, dry electrolytic condensers, paper condensers, and paper transmitting condensers, is announced by A. M. Flechtheim & Co. A catalogue, descriptive of their line, may be obtained free of charge by writing to this magazine and enclosing postage to cover mailing charges. Service Men and constructors will find this catalog useful when replacement parts are needed.

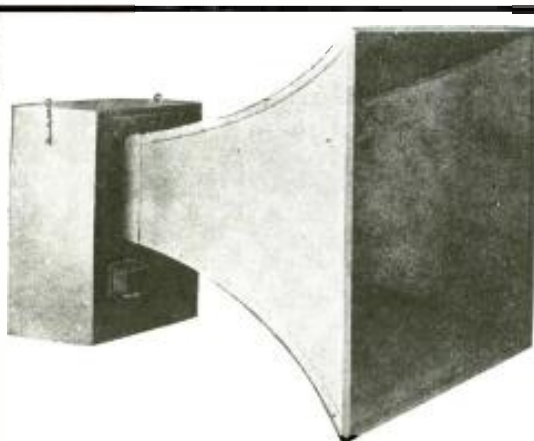

## JENSEN PERI-DYNAMIC PROJECTORS

### Another Winner

Certainly Jensen Auditorium Speakers, Ortho-dynamic and New Concert Models (A-12) are winners. And now Jensen Peri-dynamic Projectors have been submitted and the verdict is already in. Everywhere they have been acclaimed as the answer to the problem of providing high quality sound reproduction with a horn type device. Already they have been used in one of the world's largest stadiums where every type

of musical program, speech, athletic contest and public event is conducted and where only the highest quality of sound, and complete coverage of one hundred thousand or more people, is acceptable.

Peri-dynamic Projectors introduce entirely new principles into the art of sound reproduction and projection; comparison with any other type of horn speaker device is confidently invited.

#### Note these features:

- The Cone Type Speaker is enclosed in an air tight and weatherproof enclosure.
- High efficiency and no power loss through back side radiation.
- Absolute reliability; no diaphragm failures.
- No back side radiation toward microphone.
- Convenient to install and suitable for every purpose, indoors or out-of-doors.
- Moderate cost.

These new Projectors offer everyone in the sound industry a new and profitable opportunity for new installations and replacement of old equipment. Write for complete information and ask about our complete line of speaker equipment—everything beyond the amplifier. Jensen Modern Sound Manual available upon receipt of 25 Cents, stamps, or coin.

**JENSEN RADIO MANUFACTURING CO.**  
6601 SOUTH LARAMIE AVENUE CHICAGO, ILLINOIS

## THE PRESTO DISC

### FOR Instantaneous Recording.

After years of research, we have developed a heavily coated disc that for quality of tone, fidelity of reproduction, and low surface noise, equals the commercial wax record. It is black in color, non-breakable, and non-inflammable.

Write us for prices and descriptive circular

**PRESTO RECORDING CORPORATION**  
139 West 19th Street New York City

## BACK ISSUES of RADIO-CRAFT

which you might need to complete your files, can still be had at the price of 25c per copy. Send us your requirements, together with your remittance in check or money order.

### RADIO-CRAFT

99 Hudson Street, New York, N. Y.



## LATEST IN RADIO

(Continued from page 203)

opening jacks and double-circuit jacks of the same manufacture. These points are very small and compact, and are handy for constructing small-space testers and analyzers.

The N point is of hardened steel, for piercing insulated wires, corroded surfaces, etc. Silver plated to insure good contact.

The P point is a needle press-point for safety in testing. It makes contact only when the handle is pressed.

Four new tip-jacks complete the line, and includes one to fit the S point, one to fit a phone tip, a circuit-opening jack, and a double-circuit jack. Each jack, in red or black, comes equipped with a set of 10 jack identification tabs, printed 1 to 7, CAP, and OHMS; the tenth tab is blank.

### PLUG-IN TYPE "B" VIBRATOR (No. 554)

ONE of a series, the full-wave rectifier illustrated is designed as a replacement of existing types of vibrator-type "B" interrupters.

A sponge-rubber sheath separates the vibrating mechanism from the aluminum case.

### A 12 TO 200 METER CONVERTER (No. 555)

THIS little "gadget" features low cost and simplicity of installation and operation. Attach the instrument to your broadcast set and presto! you are able to receive police, aircraft, amateur, short-wave broadcast and other thrilling signals and programs on wavelengths from 200 meters, the limit of low-wave reception obtainable on most broadcast receivers, to 12 meters, the lowest practical wavelength to which expensive "all-wave" receivers can tune.

## INTER-CONTINENTAL RADIOTELEPHONY

(Continued from page 207)

L. I., or Lawrenceville, N. J. From there contact is made to either Cupar (Scotland) or Baldock (England) which are the receiving station posts for the aforementioned transmitters, respectively. From either one of these 2 listening posts land-line connection is made to Berlin and, finally, Mr. Smith. The transmitting station for the return conversation is located at Rugby, England, which directs its waves to a listening post (receiving station) located either in Houlton, Maine, or Netcong, N. J.

The question may arise in some of our readers' minds, "can the short-wave receivers now popularly used tune to the wavelength employed by these radiophone stations, and if so, how are the 'phone conversations assured of privacy." The answer is that while most short-wave receivers can tune to the wavelengths employed for trans-continental 'phone conversations, the reception will be just a garbled "hash" of sound. Just before the voice impulses are transmitted, they are broken up by frequency inversion ("The Speech Inverter," RADIO-CRAFT, October, 1931, page 226)—the word "scrambled" better explains this process, and without the necessary synchronizing or "unscrambling" devices, with which all of the listening posts are equipped, the resulting reception sounds like an unintelligible jargon.

In illustration 1, can be seen the receiving set which is used for the reception of the impulses that travel such long distances. It employs an infinite number of stages (tubes) of amplification to build up the strength of the feeble impulse to the required level. It also includes automatic volume control stages to compensate for fading so that the speech will be clear and at a constant level throughout the conversation. Photo 2 illustrates the same receiver with the front panels removed. If you ever have had occasion to see the "insides" of your radio receiver and thought it complicated, glance again at this photo and be amazed.

And while making any comparisons, using your set for a basis, just look at photos 3 and

4. Your receiver's tubes would be like a pigmy alongside of Goliath, if they were to be placed alongside of these giant tubes. These tubes must be water cooled when they are in operation.

In 5 are shown the antennas and towers employed for transmission purposes at Lawrenceville, N. J. In winter the wires become covered with sleet and ice which endanger the electrical as well as physical properties of the antennas. To remove this danger, an arrangement such as that shown in 6 is employed for melting the sleet off the wires: (1,000 V., 60 cycles alternating current is required for this purpose).

In 7 can be seen the transmitting and monitoring equipment employed at Lawrenceville, N. J. An operator is in constant attendance checking the quality and other characteristics of the transmission.

At 8 can be viewed the Lawrenceville station's various panels to which incoming land lines are connected. It is here that the 'phone message is routed to the transmitters and where land-line 'phone communication ceases and radiophone operation begins.

Number 9 shows the general layout of the transmitting room at Lawrenceville, N. J., with its multitudinous panels and racks of transmitting and power supply equipment.

The sequence of a trans-continental 'phone message is shown in 10, in block diagram form, from the moment it leaves the regular toll switchboard to the actual radio transmission and reception of the voice impulses.

It is certain that the reliability of short-wave transmission and reception is now an assured fact, considering the adaptation of this method of voice communication by so conservative and efficient a company as the A. T. & T.

## THE NEW ALL-WAVE "1/2-DOUBLET" ANTENNA

(Continued from page 212)

TABLE I

Meters	Megacycles	"A" or "B"
49	6.11	38.2 ft.
31	9.7	24.2 ft.
26	11.5	20.25 ft.
19	15.8	14.85 ft.

Connected as a 1/2-wave aerial, the aerial transformer is not used. The receiver is not grounded of course and neither is any part of the antenna system. The settings of switches Sw. 1 and Sw. 2 on the receiver transformer are the same as for the Marconi system.

The use of the multiple-doublet idea may be had by connecting additional flat-tops as shown in dotted lines. These additional flat-tops should be at least 5 ft. apart. Multiple doublets will assist in giving better sensitivity to the receiver over a wider range of frequencies, particularly those to which the flat tops are purposely designed.

### Noise Elimination Features

One of the most vital problems confronting the successful operation of all-wave and dual-wave receivers today is that concerning noise versus signal. As is commonly known, noise can be introduced into a well-shielded receiver through the aerial, ground or power line or house wiring system.

Perhaps one of the worst sources of noise trouble is due to power line or house wiring, particularly where old methods of wiring were used. Figure 3A illustrates roughly the wiring of a typical house showing branch circuits, etc.

The house wiring and its branches act as open oscillatory circuits and radiate noise at broad frequencies, as shown in Fig. 3B.

By connecting the power line filter (a specially constructed R.F. condenser in a convenient socket, preferably the one to which the radio receiver is connected) in series with the power cord, at least two changes occur: first, the equivalent tuned circuits of the house wiring are detuned through introduction of the capacity of the line filter; secondly, the open oscillatory circuits are actually closed, that is, their free end is brought to ground through the line filter. This greatly reduces the radiating properties of the house wiring and a substantial reduction of noise is generally brought about.

## LATEST SYLVANIA SERVICE HELP!

YOURS!! for  
10c in  
STAMPS

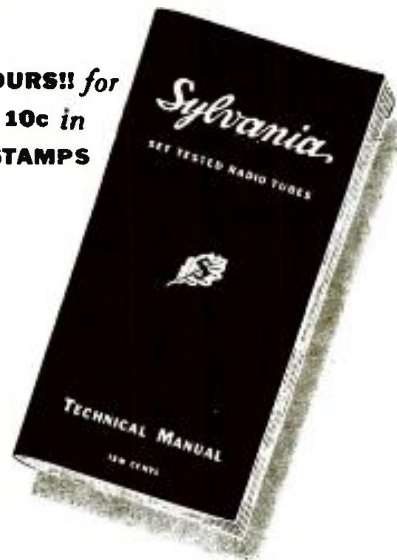

COMPLETE DATA ON ALL TUBES INCLUDING TYPES 15, 18, 255, 25Y5, 2Z2, 46B1, and 182B. . .

A convenient 104-page Manual containing essential information users must have to get optimum performance from any device using vacuum tubes.

You need it on every service job. Complete data on over 90 tubes, with base symbols, recommended operating conditions, circuit applications, amplifier classifications. Over 150 cuts and diagrams. Much data never published before. Necessary as your voltmeter.

HYGRADE SYLVANIA CORPORATION

Makers of  
SYLVANIA TUBES  
HYGRADE LAMPS  
ELECTRONICS PRODUCTS  
© H. S. Corp., 1934

Factory.  
ST. MARY'S, PA.  
EMPORIUM, PA.  
SALEM, MASS.  
CLIFTON, N. J.

**Sylvania**  
THE SET-TESTED RADIO TUBE

### 10c-TECHNICAL MANUAL-10c

Hygrade Sylvania Corporation,  
Emporium, Pennsylvania. (B-15)

Please send me the new Sylvania Technical Manual.  
I enclose 10 cents in stamps.

Name .....

Address .....

City .....

State .....



Mr. E. H. Rietzke, President of CREI, former chief instructor at Naval Research Laboratory, and an outstanding figure in the Radio profession.

## The CREI Home-Study Course Will Not Only IMPROVE Your Service Work—but INCREASE Your Income!

Every ambitious radio service man wants to improve himself and plan for a better future . . . CREI training can do that by increasing your efficiency to handle MORE jobs in LESS time.

### Practical Right from the Beginning

After the first few lessons, your gained knowledge and efficiency will start paying for this course . . . by enabling you to handle more jobs in less time. This course is written for serious-minded men who would rather be SERVICE ENGINEERS than SERVICE MECHANICS.

*Costs you Nothing to Find Out Details Write today for full information about the course and how you can pay for it.*

### FREE SAMPLE LESSON

"Audio frequency Amplification—Public Address Systems" will be sent without obligation at your request. Just write for lesson No. 45.

SEND FOR FREE 40 PAGE CATALOG

## CAPITOL RADIO ENGINEERING INSTITUTE



14th and Park Road, Washington, D. C. Dept. RC-10

### USE SHURE

### "Automatic Friction-Lock" FLOOR STANDS

for All Types of Microphones

Ask Your JOBBER About SHURE MICROPHONES and RELATED EQUIPMENT



### YOU NEED THE SHURE TECHNICAL BULLETIN!

A monthly publication devoted to Microphones and their applications. Sample copy, 6c. One year subscription, 50c.

### SHURE BROTHERS COMPANY

Microphone Headquarters

215 W. HURON ST., CHICAGO, U.S.A.

### METAL LOCATING INSTRUMENTS

WE have decided to make available to the public, our experience in the design and use of the very latest in vacuum tube metal locating apparatus. If you are contemplating the construction of, or have encountered difficulty with such instruments, it will pay you to make use of our candid, unbiased advisory service for genuinely authentic information.

If you are definitely searching for buried metals, you will save a great deal of expense and disappointment by determining beforehand what type of instrument is best suited for your purpose, and what chances you have for a recovery. Communications should include full details as to nature and amount of buried metal, its probable depth, extent of ground to be covered, surface conditions, etc.

Minimum charge \$1.00. Prices for special services and detailed constructional reports, quoted on request.

L. Mitchell Barcus, Experimental Research  
Torrance, California

If you are interested in servicing electric refrigerators, write Gernsback Publications, Inc., for circular on the Official Refrigerator Service Manual.

## A COMPACT TUBE TESTER

(Continued from page 220)

leakages and shorts between various elements in different types of tubes, and the writer will not digress here to write the several pages of "pros" and "cons" that would be necessary for an intelligent discussion of this topic. It will suffice to say that it is important in the case of a few tubes today, and might be of considerable value for some of the tubes of the future. Therefore, a short and leakage indicator is incorporated in this unit and is operated by means of the short test selector switch Sw1. This one switch automatically indicates the two elements that have a short or a high resistance leak. The little neon lamp L-1, glows brilliantly for a short, and lights up moderately for a leak. The lamp is rated at only 1/25 watt, and consequently easily shows up a leakage of 2,000,000 ohms—a much greater range than can be obtained on most commercial testers. Eight different combinations of shorts and leaks are instantly ascertained with only one switch, and spare positions are available for future additional tube elements.

A new type of test creating a plate voltage shift with emission test has been devised, which has proven unusually sensitive and accurate, and has been advocated by leading test equipment engineers. A specially designed circuit of this character is used in this tester as shown in the wiring diagram Fig. 1. The two selector switches Sw2 and Sw3, are used for the various inter-element connections required for the various tubes. Sw2 has 12 positions A to M, and Sw3 has 12 positions N to Y. The tabulation, 1, shows these switch settings for all types of tubes. All of the tubes on the market to date require less than one-third of the possible combinations of these selector switches, so that it is evident there is spare capacity for an enormous number of new types of tubes that might be brought out in the future.

### Current-Range Control

In addition to the above safeguard against obsolescence, the indicating meter is provided with a variable shunt, which can increase its range to 70 milliamperes, if required. This is a protection against the appearance of any high plate current tubes of the future. The prime feature of the variable meter shunt is, however, to automatically adjust the range of the meter for each tube under test, so that a single scale can be used for all tubes. Meter M-2 is an 0-5 D.C. milliammeter, with a specially calibrated dial and the variable shunt R2, has a high resistance of 25 ohms and a low resistance of a small fraction of an ohm.

Simplicity is again featured, in that only one socket of each different prong tube base is used. It is therefore impossible to insert the tube in the wrong socket and the nuisance is eliminated of referring to a chart and then looking for the proper socket. The filament selector switch Sw4 applies the required filament voltage to all sockets. The settings for various tubes will be described at the end of this article.

The entire instrument is light, compact and substantial. The overall panel dimensions are 8 1/4 x 11 ins., and the case provides a slope of about 30 degrees to the panel. The case also has a reinforcing strip across it, against which the transformer T may rest. The transformer is mounted on the panel, but the reinforcing strip will prevent any tendency for the transformer to sag and bend, or buckle the panel.

### Construction Notes

The assembly is simple, although it is important to first mount the neon lamp housing before doing anything else. It is also best to wire the interconnections necessary between all points on each selector switch, before mounting the switches. After mounting selector switches, wire the interconnections between the different switches, as per diagram (Fig. 1). Be sure to use insulating centering washers when mounting the line voltage rheostat VR1 and the valuable shunt rheostat VR2. The usual precautions must be observed when attaching the knobs to the selector switches and rheostats, so that the indication corresponds to the true position of the switch, or rheostat. Check the wiring carefully with the diagram, before putting the tester into operation.

### Operation

Connect the plug to a 60 cycle voltage supply and turn tube selector switches to "off" position (knob indicators at bottom position). Insert tube to be tested in its socket and operate the short test switch for indication of shorts or leaks between elements. The switch positions are marked according to the IRE and RMA accepted numbering. Therefore if the neon lamp glows at position 6-2, it indicates a short or leakage between elements connected to base pins "2" and "6".

If tube shows up all right, turn short test switch to "off" position and according to the chart, set the tube selector and filament switches to their proper positions and then turn short test switch to "regular" position. Adjust line voltage control so that line voltage meter indicates at arrow. Adjust shunt until M indicates 20. This gives the "regular" reading to which the tester is adjusted.

For actual test, only one switch Sw5, marked "test" is used for all tubes, except rectifiers. The first plate reading of all rectifiers is indicated immediately on the meter. The second plate of all full-wave rectifiers is indicated by pressing the "2nd plate" switch. Diode detectors are indicated directly without pressing any switch. The scale is calibrated at a definite point for diodes. Every separate set of elements in the combination tubes are individually tested. This tester is unusually flexible and adaptable for varied tests on a single tube.

Heretofore, it has been necessary for the customer to bring his tubes to the radio shop, if he was desirous of obtaining a direct- or English-reading indication of the relative merit of his tubes. The new tester brings this service into the home.

### List of Parts

- Two Dependable No. 312 selector switches, Sw1, Sw3;
- One Dependable No. 212 selector switch, Sw2;
- One Dependable No. 110 selector switch, Sw4;
- Two SPDT momentary toggle switches, Sw5, Sw6;
- One Dependable No. 411 milliammeter, 0-5, M1;
- One neon lamp type T-2 with mounting, L1;
- Four large knobs with indicators;
- Two small knobs with indicators;
- One Dependable 917 voltmeter, 0-35, M2;
- One 2200 ohm wire wound resistor, R2;
- One 600 ohm wire wound resistor, R3;
- One 1 meg carbon resistor, R1;
- One rheostat, 200 ohms, VR1;
- One rheostat, 25 ohms, VR2;
- Two insulated centering washers for 1/2-in. hole;
- One central grid cap and lead;
- One cord and moulded plug;
- One Dependable 304 panel, etched and drilled;
- One Dependable case (counter model or portable);
- Five moulded ring sockets V1, V2, V3, V4, V5;
- Screws, nuts-washers-wire;
- One Dependable transformer, T.

The tester—ready for outside jobs.

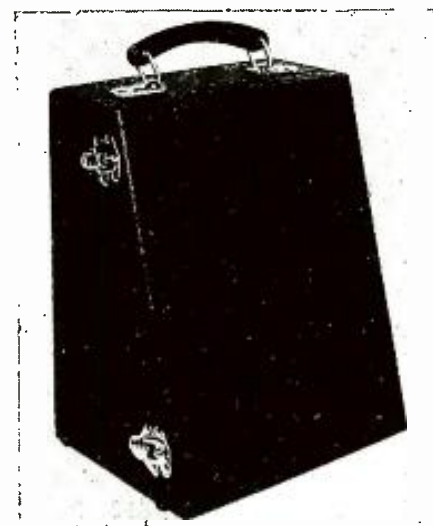

TABLE I

Tube Test Data				
Tube type	Fil. Volts	Fil. Sw. Setting	Tube Sel. Settings	Remarks
00A	5.0	6	B	
01A	5.0	6	B	
1	6.3	7		
10	7.5	8	B	
12A	5.0	6	B	
14	14.0	9	AN	
15	2.0	3	AN	
17	14.0	9	AN	
18	14.0	9	AN	
19	2.0	3	AN	
20	3.3	5	B	
22	3.3	5	A	
24A	2.5	4	AN	
25S	—	—	—	
26	1.5	2	B	
27	2.5	4	AN	
29	2.5	4	AN	
30	2.0	3	B	
S30	—	—	—	
31	2.0	3	B	
32	2.0	3	A	
33	2.0	3	AO	
34	2.0	3	AO	
35	2.5	4	AN	
36	6.3	7	AN	
37	6.3	7	AN	
38	6.3	7	AN	
39	6.3	7	AN	
40	5.0	6	B	
41	6.3	7	AN	
42	6.3	7	AN	
43	2.5	10	AN	
44	6.3	7	AN	
45	2.5	4	B	
46	2.5	4	AN	
47	2.5	4	AO	
48	30.0	10	AN	
49	2.0	4	AN	
50	7.5	8	B	
51	2.5	4	AN	
52	6.3	7	AN	
53	2.5	4	AN	1st Test
			MP	2nd Test
55	2.5	4	CN	Triode
			DQ	Diode
56	2.5	4	AN	
57	2.5	4	AN	
58	2.5	4	AN	
59	2.5	4	AN	
64	6.3	7	AN	
65	6.3	7	AN	
67	6.3	7	AN	
68	6.3	7	AN	
69	6.3	7	AN	
71A	5.0	6	B	
75	6.3	7	CN	Triode
			DQ	Diode
76	6.3	7	AN	
77	6.3	7	AN	
78	6.3	7	AN	
79	6.3	7	AR	1st Test
			MO	2nd Test
80	5.0	6	F	Make 2nd Plate Test
81	7.5	8	F	
82	2.5	4	F	Make 2nd Plate Test
83	5.0	6	F	Make 2nd Plate Test
84	6.3	7	FN	Make 2nd Plate Test
85	6.3	7	CN	Triode
			DQ	Diode
87	6.3	7	AN	
88	6.3	7	AN	
89	6.3	7	AN	
95	2.5	4	AN	
98	6.3	7	AN	
99	3.3	5	B	
291	—	—	—	
293	—	—	—	
295	—	—	—	
401	3.0	5	B	
482	5.0	6	B	
483	5.0	6	B	
484	3.0	5	B	
485	3.0	5	AN	
486	3.0	5	B	
586	7.5	8	B	
841	7.5	8	B	
864	1.0	1	B	
866	2.5	4	A	Use Connector
868	—	—	A	
874	—	—	A	
(R)985	5.0	6	FN	Make 2nd Plate Test
1A6	2.0	3	EO	1st Test
			CO	2nd Test
2A3	2.5	4	B	
2A5	2.5	4	AN	

Tube type	Fil. Volts	Fil. Sw. Setting	Tube Sel. Settings	Remarks
2A6	2.5	4	CN	Triode
			DQ	Diode
2A7	2.5	4	AN	1st Test
			MS	2nd Test
6A4	6.3	7	BO	
6A7	6.3	7	AN	1st Test
			MS	2nd Test
12A5	12.6	7	AR	
	6.3			
2B7	2.5	4	AN	Pentode
			MQ	Diode
6B7	6.3	7	AN	Pentode
			MQ	Diode
6C6	6.3	7	AN	
6C7	6.3	7	BN	Triode
			MQ	Diode
6D6	6.3	7	AN	
6D7	6.3	7	AN	
6E7	7		AN	
2F7	—	—	—	Pentode
			AN	Triode
			MS	Pentode
6F7	6.3	7	AN	Triode
			MS	Triode
2S	2.5	4	FN	
6Y5	6.3	7	HT	Make 2nd Plate Test
5Z3	5.0	6	F	Make 2nd Plate Test
6Z3	6.3	7	B	
12Z3	12.6	9	B	
6Z4	6.3	7	FN	Make 2nd Plate Test
6Z5	6.3	7	HT	Make 2nd Plate Test
12Z5	12.6	9	GT	Make 2nd Plate Test
25Z5	25	10	GT	Make 2nd Plate Test
AD	6.3	7	B	
AE	12.6	9	AN	
AF	2.5	4	F	Make 2nd Plate Test
AG	5.0	6	F	Make 2nd Plate Test
GA	5.0	6	AO	
KR-5	6.3	7	AO	
KR-20	2.5	4	CN	Triode
			DQ	Diode
KR-22	6.3	7	CN	Triode
			DQ	Diode
KR-25	2.5	4	AN	
LA	6.3	7	AO	
PZ	2.5	4	AO	
PZH	2.5	4	AN	
76	6.3	7	AN	

## A POWER-BOOSTING ANTENNA SYSTEM

(Continued from page 208)

the only economical method remaining is to change the tuning of the reflector. This changes the phase angle of the current in the reflector and thus will change the phase angle of its radiation field, with respect to that of the exciter. To obtain the highest ratio of front to back signals with a .25-wavelength spacing the reflector antenna will have to be tuned to the same frequency as the exciter.

The actual tests at KYW of this antenna system indicated that (in a direction forward to the exciter unit) the signal was almost twice as strong as that produced by the original diamond shaped antenna. That is, if the same field were to be produced by the old antenna, approximately four times as much power would have to be supplied from the transmitter. The tests also indicated that the signal directly behind the reflector could not be completely cancelled unless the reflector was directly excited. However, it was felt that the signal in the direction directly behind the reflector should not be less than from 1/2 to 1/3 of that in the direction in front of the exciter. This signal ratio was obtained without exciting the reflector directly from the transmitter, and since it permitted such a simple setup of feeder lines to the exciter antenna only, it was left that way for permanent service.

This antenna is a good example of the increased efficiency of higher vertical antennas. While the increase of signal finally obtained at KYW partly came through the use of a reflector, the new vertical exciter unit when used alone, indicated that its signal was equal to approximately twice the power in the old diamond shaped antenna with its four masts and horizontal network of wires. There seems to be little doubt that the efficiency of most of the aerials as used now in broadcasting could be appreciably increased with only a moderate expenditure of money.

**NO. 1181**

**T**RIPLETT engineers developed the ALL-WAVE Oscillator, in answer to the growing demand from service men for a well designed, completely shielded all-wave signal generator. This new Triplet instrument is advanced in design, precision built, compactly constructed, and absolutely dependable. It gives a signal output of constant level . . . either modulated or unmodulated.

The charts are hand calibrated and cover a frequency range of 110 to 18,000 KC. The frequency ranges are controlled by a 4-position band change switch. All bands covered as fundamentals. The condenser shaft is at ground potential. This means there is no radiation of signal from condenser shaft or screws. A perfected attenuator control makes it possible to use the signal generator on the most sensitive as well as the weakest receivers.

No. 1151 is a single All-Wave Oscillator. Dealer's net price . . . \$23.34

No. 1180 is made up of the combined All-Wave Oscillator and Volt-Ohm-Milliammeter. Dealer's net price . . . 30.00

No. 1181 is a combination of Volt-Ohm-Milliammeter, Free-Point Tester, and All-Wave Oscillator. Dealer's net price . . . 38.00

*Your Jobber Can Supply You*

**The Triplet Electrical Instrument Co.**  
82 Main St. Bluffton, Ohio

**Mail today for details!**

**The Triplet Electrical Instrument Co.**  
82 Main St.,  
Bluffton, Ohio.

Gentlemen:  
Send me catalog on Triplet ALL-WAVE Oscillator,  
and your complete line of radio servicing instruments.

Name .....

Street Address .....

City ..... State .....

# BUILD YOUR OWN SHALLCROSS UNIVERSAL TESTER

For \$41.50 Complete



**VOLTS  
A.C.-D.C.**  
5-25-100-250-1000  
1000 ohms  
per volt

**MILLI-  
AMPERES  
D.C.**  
1-10-100-1000

**CAPACITY**  
.001 - 10 Mfd.  
Paper or  
electrolytic  
condensers

**INDUCT-  
ANCE**  
1 - 10,000 Henrys

5-5,000,000 ohms D.C. Resistance

Send 6c in stamps for the new Bulletin No. 611-P containing the complete wiring diagram and operating instructions for this modern serviceman's instrument.

**SHALLCROSS MFG. COMPANY**

Electrical Measuring Instruments  
and Accurate Resistors

700 MAC BARR BOULEVARD  
COLLINGDALE, PA.

Be sure to turn to page 246 of this issue and get full particulars about the OFFICIAL AUTO-RADIO SERVICE MANUAL and the new FREE Supplements.

## THE SET YOU HAVE ALWAYS WANTED



the "MJ" for the truly critical  
There is no finer all-wave receiver  
Write for Details  
**PIONEER SOUND LABORATORY**  
135 Liberty St. New York, N. Y.

## RADIO BARGAIN CATALOG

**FREE** Send for 24-page Bargain Catalog showing the complete new 1935 Goldentone line of radios. Many models to choose from, including world-wide all-wave, dual wave, short wave, midjets, consoles, 32-volt, Air Cell, car radios, etc. All sent on 30-day HOME TRIAL. Before you decide get our Catalog and save money. Prices from \$9.45 up. Only catalog giving cabinet and chassis photos, circuit diagrams and complete engineering specifications. Deal direct, save half. We pay postage. **GOLDENTONE RADIO COMPANY, Dept. 102**  
4180 Oakman Blvd., Detroit, Mich.

## SHORT CUTS

(Continued from page 225)

### A PLUG-LESS ANALYZER CABLE

E. Chadima (Honorable Mention)

THE controversy as to how many, and what kind of adapters to use in conjunction with the analyzer cable may be answered in a very easy manner—just don't use any adapters. The way in which the writer solved this problem is shown in Fig. 4.

Although only one lead is shown, the writer has made up a cable consisting of the requisite number of color-coded wires, each of which terminates in a test prod. The feature of the arrangement is that each test prod is equipped with prongs taken from a tube base.

Although it takes a little longer to handle a cable of this type, there is never any need to hold up the testing for lack of adequate means of making contact to the tube-socket contacts.

### ELECTRIC TIME-SWITCH CLOCKS

C. Bradner Brown (Second Prize)

ONE of the most useful devices the experimenter can construct is an electric time switch. With this device, the radio set may be turned off or on at a specified time. Store lights may be arranged to be turned off at a late hour of the night instead of allowing them to burn until the next morning. The author decided to design and construct such a mechanism which would be reliable and yet would not require too much labor to build.

The heart of the device is the self-locking relay especially designed for this circuit. When it is once tripped, it holds itself in place until another control is actuated. This relay together with an ordinary electric alarm clock constitute the simplest time switch that can be constructed for such duty.

The relay is constructed from a 1000 to 1,200 ohm telephone ringer coil. The coil used by the author had screws tapped into each end. The larger screw had a large flat head which constituted the pole face. A copper or brass support bent into a U shape is shown in Fig. 6 This constitutes the main support and cannot be made of iron as the magnetic leakage would interfere with the operation of the relay. The armature itself is bent from a piece of soft iron and is fitted with 2 small screws on the upper end which constitute the pivot bearings. These screws pass through nuts soldered to the armature and are in turn locked in place with a pair of extra nuts. The inner ends of the screws are ground or filed to a conical point to reduce friction. These points are the armature bearings and fit into small holes drilled in the iron cross-piece on the top of the coil. This cross-piece is held in place by a single screw tapped into the iron core as shown. Another screw passes through the long arm of the armature and transmits the motion to the contacts and power switch. The armature should swing back and forth easily in its pivots (just clearing the pole face at the end of its travel).

The holding contacts are taken from an old jack and are mounted so as to close when the outer and longer spring is moved toward the relay proper. The best results will be obtained if rather limber springs are selected. These blades should be entirely insulated from the frame but this will not be difficult to do. A "vacuum contact" type of switch is mounted on the side opposite the holding contacts. A small piece of felt prevents the glass from coming in contact with the metal and eliminates any chance of breakage. Two fibre collars are provided which fit snugly over the glass stem of the vacuum contact switch and the actuating screw, S, which transmits the motion of the armature. A small spring is fastened to these fibre collars and the outer arm of the holding switch. The contacts are set as follows:

When no current is flowing in the armature, Jack spring J pulls the armature to the position shown at 6B and also forces the vacuum contacts apart, breaking the power circuit. When current flows, the armature is pulled into position 6C, closing the holding contacts and allow-

ing the vacuum contacts to close by releasing the tension on spring V.

The use of the auxiliary spring, V, is to smooth out the action of the relay and to prevent any possibility of damage to the vacuum contact.

Once the relay has been constructed and tested on about 60 volts A.C. by placing it in series with a 1000 ohm resistor, an electric alarm clock should be secured and remodeled as follows:

Remove the case carefully and locate the alarm contacts. Disconnect these from the ringing circuit and bring out two insulated wires from them. The alarm clock and relay are then connected as shown in Fig. 5A.

This circuit is probably the most satisfactory and flexible to construct. The D.P.S.T. switch controls the action of the relay, causing it to either open or close the circuit. The function of the holding contacts is to remove the load from the alarm contacts and hold the relay in the closed position until further actuated either manually or by the alarm contacts.

When the S.P.D.T. switch is in the "on" position, the closing of the alarm contacts will cause the relay to close and since the holding contacts at once become effective the relay will remain closed until manually operated. If the S.P.D.T. switch is in the "off" position, the alarm contacts will short the coil and release the relay—providing it is in the "on" position. Switch M has been provided for manual operation of the relay. When it is in position A the operation is automatic, but if it is placed in the other position the relay immediately follows the S.P.D.T. switch setting.

The operation in turning off the radio set at some late hour, for instance, is as follows:

The radio is turned on by placing the S.P.D.T. switch in the "on" position and tripping the manual switch. The S.P.S.T. switch is then placed in the automatic position and the S.P.D.T. switch set at "off." When the alarm reaches the desired hour the radio set will then be turned off. A similar procedure can be arranged to turn the radio receiver on at a predetermined hour by merely placing the S.P.D.T. switch in the "on" position with the other switch at A. If the time switch is intended for turning off lights only, it may be constructed somewhat easier as shown in Figure 5B.

Since the self-locking relay is the heart of all these devices, the author leaves further circuits to the experimenter.

Fig. 6  
Mechanical details (A), and the electrical action of the relay (B, C) are shown.

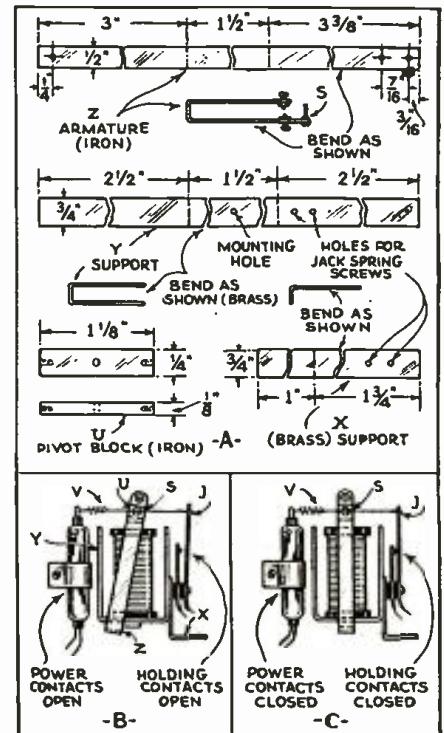

## CONVERTING OLD SETS

(Continued from page 219)

voltage to all the tubes would then be 2.27 V., or above the tube's extreme limit for safe operation. All values for the individual resistors are shown in Fig. 1C.

An interesting variation of the output circuit in this same set is to use type 33 pentodes in place of the 31s. This arrangement gives extreme power with apparent increase in sensitivity, since where noise level is low many weaker signals may be brought up to good volume. The sockets for the output must be changed to 5 prong type. The detector plate resistor which is mounted on the present 2 prong socket panel can be moved to another location. If a suitable output transformer is used this change will be found very gratifying and well worth the trouble. Connections are shown in Fig. 2.

It will be noted also that when any of these changes are made only 135 V., or 3 "B" batteries are used, whereas the original circuit called for 180 V.

## IMPROVING ECHOPHONE MODEL C

James K. Coates

THERE are several thousand Echophone model C midjet-type 6 tube sets in existence; this radio receiver uses 3 01As, 1 71A, 1 27, and 1 80 rectifier. A later, model D, set uses the same circuit, the only difference being that it is built on a steel chassis instead of on the wood back panel.

I have found that by making two simple changes on the filament wiring of the 01As, as shown in Fig. 3, and then substituting 26s in their place, not only is the sensitivity of the set greatly increased, but also the had A.C. hum due to A.C. on the 01A filament is reduced so that it is hardly noticeable. The regeneration control also operates much better with the new tubes, as you can get closer to resonance without hum. Here are the changes to be made.

Locate the 5 V. winding that lights the 3 01As, (the wires are usually brown—and center-tap wire blue). Remove the center-tap wire and resolder in its place one of the brown ones; the blue wire now goes to the center-tap of a 40 ohm resistor, which is placed across the new filament supply (which gives almost 2.5 V., and with the 26s in place is reduced to about 1.75 V. due to the increased current drain).

These sets use a magnetic speaker and I find that the tone can be improved a great deal by connecting a .025-mf., 400 V. condenser from the plate of the 71A output tube to ground.

Be sure to re-balance the set at 1,450 kc. This will eliminate circuit oscillation due to the higher mu of the new tubes.

## INFORMATION BUREAU

(Continued from page 228)

The resonant frequency will be that frequency corresponding to the maximum current. The frequency of resonance is determined by the capacity and inductance of the circuit, and is equal to,

$$F = \frac{1}{2\pi \times 3.1416 \sqrt{LC}}$$

where L is the inductance of the circuit in henries, C is the capacity in farads, and F is the resonant frequency in cycles per second.

In the design of radio receivers tuning over a wide frequency range, one method whereby a single coil can be made to cover a wider range of frequencies is by the use of a switch which cuts a condenser into the circuit in series with the main tuning condenser. The effect of the condenser in series with the main tuning condenser is to reduce the capacity and thereby to increase the resonant frequency of the circuit.

For example, suppose that the main tuning condenser in a resonant circuit has the maximum capacity of 250 mmf. (.00025-mf.) and that in combination with a coil this capacity will tune to a minimum frequency of 500 kc. If we connected in series with the tuning condenser as

## As An Introductory Offer You Can Now Have 110 Volts A.C. In Your Car or Motor Boat for as Little as \$9.50

EASY TO INSTALL—NO DRAIN ON BATTERY

# POWER RACK

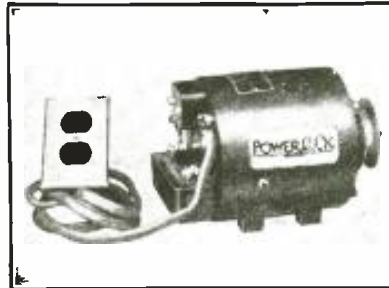

### HOW TO ORDER

Remittance in full or a 25% deposit required. Do not send Cash unless registered. A Money Order will insure prompt shipment. A check will delay shipment. Units will be shipped by Railway Express, charges Collect. Terms of Sale: Net/Cash, F.O.B. New York City. All units fully guaranteed against factory defects.

This offer is limited. Act now!

Operates from fan belt and draws no current from car or boat battery. Delivers 110 Volts for Camp Lighting, Radio Receivers, Speech Amplifiers, Neon Signs, Spot Lights, Electrical Appliances. For the Camper, Doctor, Tourist, Towing Car or Motor Boat. POWER RACK delivers the same electric current as you have in your home. Use your home radio, either A.C. or A.C.-D.C. POWER RACK is noiseless, ruggedly constructed and needs no care or upkeep.

Model 21—50 watts output ..... Your Net Cost **\$9.50**

Model 23—100 watts output ..... Your Net Cost **\$13.50**

Model 26—175 watts output ..... List Price **\$65.00**

Comes complete, ready for installation with Mounting base, BX Cables, Outlet Box, Output Rheostat and full operating instructions. Shipping weight: Model 21, 29 lbs.; Model 23, 35 lbs.

**THE POWER RACK CO., 363 SEVENTH AVE., N. Y. CITY**

## A Book Every Radio Man Needs!

HERE is one radio book, "RADIO NOISES AND THEIR CURE," that answers every conceivable question on interference. It contains 76 pages, 8 1/2 x 11 inches, check-full with wiring diagrams, drawings and photographs showing where interference originates—how it is distributed, and how to eliminate it. This is a wealth of information needed by every radio listener, dealer and Service Man.

Send fifty cents in stamps or 50¢ check for this book.

**RADIO-CRAFT, 99 Hudson Street, New York, N. Y.**





**A NEW AND COMPLETE LINE**

## POWER WIRE WOUND RESISTORS



**AT LAST! A CERAMIC CORE THAT WON'T ABSORB MOISTURE!**

**ELIMINATES DANGER OF BREAKAGE, TOO!**

**JUST THE THING FOR MY X-MITTER!**

**LOOK AT THAT NEW CEMENT COATING AND PLENTY OF STRENGTH AND IT DISSIPATES POWER QUICKLY!**

**WHEN I FIX SETS WITH THESE THEY'LL STAY FIXED—NO MORE BURNOUTS!**

**BOY, HONDI! I'LL USE PLENTY OF THESE ADJUSTABLES BOTH IN MY SERVICE WORK AND IN MY SHACK!**

**IT'LL MAKE A 100V VOLTAGE WORK ON BATTERIES!**

**WATTAGE RATINGS GO UP!**

**HURRAH! IRC MOLDED END CONTACTS!**

**EVERY NEEDED STYLE AND SIZE!**

**PRICES COME DOWN!**

**INTERNATIONAL RESISTANCE CO.**  
2100 ARCH ST., PHILADELPHIA, PA.  
In Canada, 187 Duchess St., Toronto, Ont.

Sold by leading jobbers... See them today! Write for the NEW IRC catalog.

**ATLANTA**  
BRANCH  
Now Open

W.R.S. CO. Now in ATLANTA

In the heart of the South, Wholesale Radio Service Company opens a New Branch dedicated to the principle that Servicemen far from the manufacturing and buying centers of the Radio World are entitled to the same low prices, complete stocks, fast service and low transportation costs as those in the North.

Our great modern Atlanta salesrooms will display the most varied and complete line of replacement parts by every leading manufacturer. There will be a special department devoted exclusively to P. A. equipment while Short Wave sets, Kits and equipment will be featured. For 13 years we have pledged ourselves to sell Quality Merchandise at lowest wholesale prices and in Atlanta—as in New York and Newark—this pledge will be fulfilled. Servicemen, Amateurs, Hams, Brasspounders and Experimenters all will welcome this New Branch in Atlanta—now the RADIO CAPITOL OF THE SOUTH!

For copy of latest catalog please write Dept. C-104

**WHOLESALE RADIO SERVICE CO.**  
100 SIXTH AVE. 430 W. PEACHTREE ST. N.Y.  
NEW YORK, N.Y. ATLANTA, GA.

**NOT FOR LOVE!**

Those radio service men who are truly business men, are not working for love! They are out to sell their professional services at professional prices. Now then: Four months ago no one ever heard of radio Chuckker. Three months ago every really good service man was talking about it. Today, every progressive radio man uses a Chuckker to eliminate guesswork in "What is Wrong and What to Charge." The repair-writer feature of this compiled, cross-indexed radio trouble-chart is based upon a \$1.50 hourly labor rate. Plus list-priced replacement parts. Show the set owner the professional fee Chuckker publishes for his radio repair job. You'll be astonished how easily you get that job, at an excellent price. Yours sent postpaid, for \$1.00 pinned to your letter. Send a DOLLAR-BILL now!

**SEND DOLLAR BILL NOW!**

**FREED'S RADIO CO.**  
Publishing Division R  
5053 Baltimore Ave. Philadelphia, Pa.

**the HARRISON 12,500 MILER—Now AC-DC**

No batteries or separate power supply needed. The set is entirely self-contained and plugs in directly into 125, AC or DC, 25, 50, or 60 cycle house current outlet. Get foreign stations, police, airplanes, etc. DIRECT with this powerful 2 tube receiver. Complete kit contains all necessary parts and large picture diagram to build set. NOW \$5.98

Two Tube Battery Model \$4.75  
ORDER NOW! Or send for free literature, Deposit required with all orders

**HARRISON RADIO CO.** Dept. R-10 142 Liberty St. New York City

**FOR CLEAR RADIO RECEPTION!**

**CORWICO NOISE-MASTER**

This remarkable new NOISE-ELIMINATOR and LEAD-IN SYSTEM gets rid of MAN-MADE STATIC, improves radio reception and helps to get foreign reception, etc. Recommended with FIVE TUBE ALL-WAVE SET and also by all leading set manufacturers. Easily installed.

Included in NOISE-MASTER system are patented aerial unit, radio set unit, two-purpose inductor and 50 ft. of shielded lead-in wire.

Priced at \$5.25 postpaid in U. S.  
Order direct if dealer cannot supply.  
Send for interesting descriptive folder.

**CORWICK WIRE COMPANY** Dept. RC—30 Chutes Street, New York, N. Y.

**Build the NEW FIVE TUBE ALL-WAVE SET**

Remarkable Distance Range-Verified reception of VK3ME, 5 watt Australian station with loud speaker volume. Also splendid broadcast reception. Send for free circular with prices of individual parts, Kit, and outfit set.

Free circulars also available describing the new ALL ELECTRIC ALL-WAVE AIR SCOUT, selling for \$9.50 postpaid ready to use.

**ALLIED ENGINEERING INSTITUTE, Dept. RCC**  
98 Park Place New York, N. Y.

shown in Fig. 1B a fixed condenser with a capacity of 250 mmf. then the circuit will tune to a minimum frequency of 700 kc. (This is one of the principles applied in radio reception to obtain "band spreading," or tuning over a greater range on the tuning dial for a given number of stations.)

If we know the range of frequency over which a given circuit will tune then we can determine the frequency range obtained with any given combination of tuning condenser and series fixed condenser by the relationship,

$$F_1 = \frac{\sqrt{C_2}}{\sqrt{C_1}}$$

$$F_2 = \frac{\sqrt{C_1}}{\sqrt{C_2}}$$

where  $F_1$  is the frequency to which the circuit will tune with the series fixed condenser,  $C_1$  is the capacity of the tuning condenser, and  $C_2$  is the capacity of the combination of the fixed condenser in series with the tuning condenser.

For example, suppose a circuit uses a 250 mmf. tuning condenser and tunes from 500 to 1,500 kc. The inductance required for such a circuit would be 400 microhenries. In order to tune to a maximum of 1,500 kc. the equivalent minimum capacity of the entire circuit would have to be approximately 27.8 mmf. Assume that we want to change the frequency range so that the minimum frequency will be 1,500 kc. instead of 500. This means that with the tuning condenser set at maximum capacity the capacity of the circuit must be 27.8 mmf.

For two condensers in series the formula for determining the value of one of these condensers (when the values of one of the condensers and the resultant capacity are known) is,

$$C_1 = \frac{C_t C_2}{C_2 - C_t}$$

where  $C_1$  is the required capacity for the series fixed condenser,  $C_2$  is the original capacity for the tuning condenser, and  $C_t$  is the required capacity for the two condensers in series.

In this example  $C_t$  is 27.8 mmf. The original capacity  $C_2$  is 250 mmf. Substituting in the formula, we have,

$$C_1 = \frac{27.8 \times 250}{250 - 27.8}$$

$$= \frac{6,950}{222.2}$$

$$= 31.3 \text{ mmf.}$$

In other words, we have to connect in series with the tuning condenser a fixed condenser having a capacity of 31.3 mmf.

It will be noted that the required series capacity of 31.3 mmf. is not much different than 27.8 mmf., the minimum capacity of the tuning condenser. Of course, when the circuit is required to tune to higher frequencies, a smaller series condenser will be required.

In the above example as a matter of simplicity we have neglected the distributed capacity of the tuning coil itself in order to simplify the problem. In actual practice, however, the distributed capacity of the coil may be an important factor.

(The above data has been selected from a recent issue of THE AEROVOX RESEARCH WORKER as being a representative analysis of important factors involved in the selection of a "padding" condenser. The use of a padding condenser is illustrated in Editions 1 and 2 of the RADIO-CRAFT Library Series volume, "The Superheterodyne.")

## A.C. CAR GENERATOR FOR RADIO OR P.A.

(Continued from page 221)

that shown in the photograph will operate directly from engine of the car, being driven by the same belt that drives the fan, and produces 110 volts A.C. which may be used not only for P.A. equipment but for radio receiver purposes as well. Or, for any other type of electrical installation that requires electric power. The output of this generator is highly desirable and an asset where neon sign advertising is desired on new demonstration cars, advertising trucks, and other similar instances.

### Construction of the Unit

The generator is constructed with an alternator winding and a field winding, both of which are on the stator of the unit. The rotor has no windings, thereby eliminating brushes, commutator and slip-rings. The field or excitation winding is connected to the generator of the car. The voltage from the car generator which is induced in the excitation winding is broken up into an alternating current and stepped up to 110 volts in the alternator winding. The rotor is driven by a pulley in contact with the fan belt of the car, as previously mentioned.

A few types make use of the part of the output of the car generator (charging) at the 6 volt terminal. This produces an excitation voltage of from 4 to 7 volts in the field winding. Other models make use of part of the output of the car generator, taking it from the 6 volt terminal and the third brush. This produces an excitation voltage of from 5 to 6 volts in the field winding, depending upon the speed of the engine. The following voltages are ratings at full load, that is, only when 50 watts are being drawn from a 50 watt unit.

Size	Idling speed	25 M.P.H.	50 M.P.H.
50 watt type	90 volts	120 volts	135 volts
100 watt type	105 volts	120 volts	105 volts

This unit should not be used in amplifier installations that employ A.C. operated phono turntables, especially of the synchronous type, inasmuch as the speed of the turntable will vary with the frequency, and since the frequency of the output varies with the speed of the engine. At idling speed the frequency is 50 cycles, while at top speed it goes to 150 cycles. However, this frequency variation will have no effect on the operation of transformer units that are designed for use on 60 cycles.

### Installation

The installation of this generator requires only a suitable bracket for mounting to the motor block of the car, and an adjustment or replacement of the fan belt so that the generator pulley is driven by it. In mounting the generator unit, it should be so installed that it is in a straight line with the other pulleys that are driven by the belt. A bracket, other than that of the standard type which is furnished with the unit, is necessary for installations in Ford V-8 models.

The A.C. voltage is carried from the unit through a standard BX cable, and is connected to a dual outlet box which can be mounted anywhere that is convenient or suitable, depending upon where the installation is to be made. This adds to the neatness and simplifies installation or removal of the equipment where portable installations are made.

### Other Uses

Although this magazine is primarily interested in the application of this device as concerns radio or amplifier equipment, it may interest the readers to learn of some additional possible uses, which may or may not be of aid to them should the problem of power supply ever arise. A great many people have cabins to which they retire whenever a vacation period arises. As a general rule these cabins are seldom equipped with electric lights. How convenient it would be to simply run a line (cable) to the outlet within the car, to another convenient outlet in the cabin, so that radio receiver operation may be enjoyed within, or for furnishing the necessary power for electric lights? Or for supplying power to a standard A.C. receiver built into a portable case that may be taken to a beach, picnic, or any place where power is not available—without that great weight imposed on the set (or its portability) by heavy "B" batteries. As a matter of fact, much more efficient and satisfactory operation will be obtained with an A.C. receiver than most portable receivers are capable of.

(Units of this general type have been described in past issues of RADIO-CRAFT, and the interest that they have aroused augurs well for a good reception of this newer and greatly improved design. The undeniable utility of this type of current supply unit recommends the device for use where other types of current supply devices are inadequate to the demand. —Editor)

## A 5 TUBE ALL-WAVE SET

(Continued from page 218)

The antenna post must be insulated from the chassis by means of an insulating washer. The chassis is then turned upside down and the triple unit metal case condenser (C4a, C7, C8) is fastened to the underside. The r.f. choke is also fastened to the bottom of the chassis as indicated. It should be kept well away from the metal. The voltage divider resistors, R11, R12, R13 and R14 are mounted on a piece of bakelite 4 x 1 x 1/8 in. and this in turn is fastened to the underside of the chassis by means of small brackets. The grid condenser C4 is fastened to the bottom of the chassis with the grid leak R3 soldered to it.

The other fixed resistors and fixed condensers, shown in the bottom view illustration are soldered in place during the process of wiring and wherever possible the various parts are soldered directly to the terminals of the parts with which they function, thus shortening and simplifying the wiring.

The chassis is now ready for wiring. Push-back wire is recommended as highly suitable for this work. The filament circuits are wired in first, including wires brought up from below the chassis for the pilot light. Twist all filament leads. Next the various grid circuits are wired, then plates, cathodes, by-pass condensers and negative returns. The iron chassis itself serves as a common ground. The wiring diagram of the receiver is shown in Figure 1.

A four wire cable, terminating in a four-prong plug provides the means of connecting the set to the power supply unit. Wires are brought out for the volume and regeneration controls and also for the variable condenser. These three parts are mounted on the front wall of the metal cabinet which serves as a panel. When the chassis wiring has been completed the chassis is fastened within the cabinet and the wiring is completed to the three components on the panel. The vernier dial is fastened to the front of the chassis and the knobs are put on the shafts of the volume and regeneration controls. Finally the back plate of the cabinet with its hinged cover is fastened in place.

The construction of the power supply is the next step. The four prong socket for the 80 tube is fastened to the chassis. Next the power supply transformer, the two filter chokes and the two inverted electrolytic condensers are mounted on top of the chassis. The "on-off" switch is mounted on the chassis side wall; also a four prong socket for making connections to the set and a four prong socket for the speaker connections. Beneath the chassis are mounted the cardboard electrolytic filter condenser C15, two mica condensers C11 and C12 and resistor R15. The wiring of this unit presents no difficulties whatsoever. The primary side of the power supply transformer may be wired in first; then the plate circuits of the 80 tube; next the five volt filament circuit of the 80 tube, then the B plus circuit through the chokes, then the filter condensers and finally the 2.5 volt circuit which feeds the filaments of the tubes in the set. Twist all A.C. wiring leads, to minimize any possibility of stray A.C. feedback causing hum.

Naturally a well-insulated aerial is a necessity for foreign reception. This need not be of any special type, but where there is local interference tending to prevent distance reception, due to motors, bells, violet-ray apparatus, etc., this interference may be eliminated through the use of a shielded lead-in system, such as have been and are being described in RADIO-CRAFT.

### Complete List of Parts

One .0005 mfd. Aerovox Mica Condenser, type 1450, C5;  
Two .0001 mfd. Aerovox Mica Condensers, type 1460, C6, C8;  
Two .006 mfd. Aerovox Mica Condensers, type 1460, C7, C10;  
Two .005 mfd. Aerovox Mica Condensers, type 1450, C1, C3;  
Two .002 mfd. Aerovox Mica Condensers, type 1450, C12, C13;  
One Triple Section Aerovox Metal Case Condenser, .5 mfd. ea. section C2, C4a, C9;  
Two 8 mfd. Aerovox Electrolytic Condensers, inverted mounting, type GM6, C14, C15;

# HAMMARLUND'S First Low-Priced S-W COILS

Wound on New XP-53  
High-Efficiency Forms



**L**OW-PRICED Hammarlund S-W Coils are now available, due to the perfection of "XP-53," the sensational new Hammarlund low-loss dielectric.

Rugged, durable, good looking, no artificial coloring. Ribbed for air-spacing. Easy flange-grips, with "meter-index" inserts for wavelength marking. Molded shelf inside coils for mounting Hammarlund trimming or padding condensers.

Set of 4 coils (4 prongs, 2 windings)  
for 15-220 meters, \$3.00 list.

Set of 4 coils (6 prongs, 3 windings)  
for 15-220 meters, \$3.75 list.

Other coils for lower or higher ranges.  
Silver-plated, low-loss secondaries on the  
higher-frequency coils.



New Hammarlund XP-53 Low-loss Coil Forms. 4, 5 or 6 prongs, 35c each list.



HAMMARLUND MANUFACTURING CO.,  
424-438 W. 33rd St., New York.

— Check here and attach 10c for 16-page Hammarlund 1935 Short-Wave Manual, illustrating and describing most popular S-W circuits of past year, with schematic and picture diagrams and parts lists.  
— Check here for FREE information on XP-53 Coil Forms and Coils.  
— Check here for FREE General Catalog.

Name .....

Address .....

RC-10

## YOUR LAST OPPORTUNITY!

The OFFICIAL AIR CONDITIONING SERVICING MANUAL will be off press in a few weeks. In order that you may still save a dollar when buying this Manual, your remittance of \$4.00 must be received on or before October 1st. The book will be ready for distribution about this date. Remember, the regular price of the Manual when published will be Five Dollars. ORDER NOW . . . AND SAVE THE DOLLAR! Mail order and your remittance to GERNSBACK PUBLICATIONS, Inc., 99R Hudson St., New York, N. Y.

Auto  
Radio

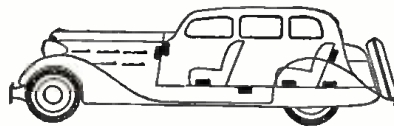

Always  
Ready

"Multi-Tap" B POWER SUPPLY UNIT  
(TRADEMARK) (PATENT APPLIED FOR)

ONLY 1 MODEL MULTI-TAP "B"

Replaces B Batteries in any of over 90% of Auto Radios

The Multi-tap "B" supplies smooth, quiet, constant "B" output voltage from the 6 volt storage battery. Drains only 4.0 amperes at maximum output—lower for smaller load—produces greater distance finding and continuous clearer tonal quality, provides 90v, 135v, 180v or 250v at various taps on the connecting block. The General full-wave Vibrator used in the Multi-tap "B" is provided with oversize contacts—insuring long life.

Easily installed—The Multi-tap "B" may be located in any convenient spot. NEG. "C" BIAS:—"C" bias may be procured by inserting a suitable resistor and by-pass condenser between —B and ground.

SCREEN VOLTAGE: Voltage for the screen grid tubes is supplied on the 90 V. terminal, which is intended for this purpose only.

### Service Engineers — Distributors!

This field is now ripe for quick profits—let's go! Write today for Auto-Radio "B" bulletin and list of Exact—duplicate Vibrators.

**GENERAL TRANSFORMER CORPORATION**  
504 SOUTH THROOP STREET — CHICAGO — ILLINOIS

**You Should Have This**  
**192 PAGES** **SHORT WAVE PUBLIC ADDRESS MANUAL**



An authoritative work on Short-Wave Receivers, Broadcast Receivers, Public Address Systems, Transmitting Apparatus and Testing Equipment. Complete informative material on radio in general, stressing the abnormalities of short-waves, its construction, functions and tuning. Complete short-wave station list, giving time and frequency. Articles by famous radio engineers—A. E. Lynch, Herman Cosman, Herman Bernard, etc.

Only **50¢** Send for Your Copy Today!

**Universal AC-DC Switch Type**

**Short Wave CONVERTER**

CAN be connected to any broadcast receiver without change of wiring. 110 volts AC or DC currents. Uses two new tubes—8A7 and 25Z5. The 8A7 is a duo purpose tube acting as a detector and oscillator. Bands tuned by a switch assembly require no manual plugging in of coils. Very selective.



Kit of parts ..... **\$7.95**  
 Wired, extra ..... **2.00**  
 Kit of tubes ..... **2.25**

Send for New 1935 Catalog

**TRY-MO RADIO CO., Inc.**  
 85-C Cortlandt St., New York City

For Building Your Fall Testing Equipment use

**VAN SILVER-ETCHED DIALS**  
 For Models 88 and 301  
 Type Nos. 1, 2 and 4 for each model

**VAN SHUNTS**  
 27mv. - 30mv. - 35mv. - 50mv.

ORDER THROUGH DEALER OR DISTRIBUTOR  
 Descriptive Folder on Request

**D. L. VAN LEUVEN**  
 410 East 15th St. New York, N.Y.

**SERVICEMEN!**

THE MOST COMPLETE LINE OF CONDENSERS AND RESISTORS FOR EVERY RADIO USE  
 Write for our new 10-page Catalog toll-free of charge



76 Washington Street Brooklyn, N. Y.

**AGENTS WANTED!**

**MOTION PICTURE SOUND**

Most fascinating field awaits live Radio Service Men—quick, sure profits  
**ASK FOR FREE CATALOGS**  
**S.O.S. CORPORATION**  
 1600 Broadway New York, N. Y.  
 Cable Address: "Sosound" New York

BE SURE TO READ THE ANNOUNCEMENT ON PAGE 196—IT GIVES COMPLETE DETAILS ABOUT THE NEW 1935 OFFICIAL RADIO SERVICE MANUAL.

- One 8 mfd. Aerovox Electrolytic Condenser, cardboard type, type P6, C16;
- One 10 mfd. 50 volt, Cartridge type Electrolytic Condenser, Aerovox, type PR50, C11;
- One .00014 mfd. (140 mfd.) Hammarlund Midget Tuning Condenser, type MC-140-M, C4;
- One 30 ohm, 10 watt Wire Wound Electrad Resistor, R15 (center-tapped);
- One 500 ohm, 5 watt Electrad vitreous resistor, type H514, R9;
- One 50,000 ohm Electrad Rheostat, type RI-205, R2;
- One 50,000 ohm Electrad Potentiometer, type RI-205, R10;
- Two 5000 ohm, 1 watt I.R.C. Metallized Resistors, R11, R12;
- Two 14,000 ohm, 1 watt I.R.C. Metallized Resistors, R13, R14;
- Two 15,000 ohm, 1 watt I.R.C. Metallized Resistors, R7, R1;
- One 2700 ohm, 1 watt I.R.C. Metallized Resistor, R6;
- One 200,000 ohm, 1 watt I.R.C. Metallized Resistor, R4;
- Two 300,000 ohm, 1 watt I.R.C. Metallized Resistors, R5, R8;
- One 5 meg., 1 watt I.R.C. Metallized Resistor, R3;
- One Set of Four Alden 6-prong Plug-in Coils, type 706SWS, 15 to 200 meters, L1;
- One Set of Two Alden 6-prong Plug-in Coils, type 706 BCS, 200 to 550 meters, L1;
- One 2½ mh. Find-All Short Wave R.F. Choke, L2;
- One 30 henry Filter Choke, Find-All type, L3;
- One 58 type Tube, 1 Alden 6-prong Moulded type Socket, V1;
- One 57 type Tube, 1 Alden 6-prong Moulded type Socket, V2;
- One 56 type Tube, 1 Alden 5-prong Moulded type Socket, V3;
- One 2A5 type Tube, 1 Alden 6-prong Moulded type Socket, V4;
- One 80 type Tube, 1 Alden 4-prong Moulded type Socket, V5;
- One 6-prong Alden Moulded type Socket, L1;
- Two 4-prong Alden Moulded type Sockets for Speaker Plug and Set Plug;
- Two Four-prong Alden Plugs;
- One Vernier Dial 1—2½ Volt Pilot Light;
- Two Screen Grid Clips—2-Knobs, 1—Line Cord and Plug;
- One Roll Corwico Braiddite Hook-up Wire, Solid Core;
- One Cornish Wire "Corwico Noise-Master" Noise-Eliminating Lead-in System;
- Four Binding Posts, BP1, BP2, BP3, BP4;
- One Metal Chassis, 9½ x 9½ x 2¼ ins. high for set;
- One Metal Chassis, 10 x 7 x 2 7/8 ins. high for Power Pack;
- One Metal Cabinet, with hinged cover and two shielded compartments;
- One Power Supply Transformer, 350 volts either side of center-tap, with 5 volt filament winding for 80 tube and 2½ volt, 5 amp. filament winding for other tubes;
- One Dynamic Speaker, with 2500 ohm field L4, and Output transformer T2, to match 2A5 tube (7000 ohms impedance);
- One Toggle "on-off" Switch, Sw.1;
- Two Four-Conductor Cables, one to connect set to power supply; other for Speaker connections.

**A CONDENSER MANUFACTURER "GOES RESISTOR"**

Until recently, the name Flechtheim has been associated only with condensers. Now, announcement is made that they have entered the fold—of resistor manufacturers. Of course, the step is quite logical in view of the close relation which one unit bears to the other.

The new resistors are carbon units, cold molded and heat treated to insure stable operation. To obviate the possibility of noise due to poor connection, the pigtail leads are soldered directly to the resistor. The units are available in all values and sizes, as required by individual receivers.

**FREE**  
**48-Page Supplement to the Auto-Radio Service Manual!**

To everyone who now purchases the OFFICIAL AUTO-RADIO SERVICE MANUAL this big 48-page Supplement is issued FREE. Practically all of the latest sets, together with servicing information will be found in these new pages. The new Supplement does not increase the cost of the book to you, but gives you an Auto-Radio Service Manual that is right up-to-the-minute with service notes.

**Good Money in Servicing Auto-Radios**

If you are overlooking servicing auto radios, you're missing a great deal of business. The auto-radio business had its greatest boom last summer when thousands of sets were sold. By now many of these same sets require servicing and with hundreds of them right in your own community, you can build up a good auto-radio servicing business. In a short time you can easily add 25% profit or more to your regular servicing business.

**List of sets covered in the Manual**

- Acme Radio Mfg. Co.
- Allied Radio Corp.
- Atwater Kent Mfg. Co.
- Audiola Radio Co.
- Autocrat Radio Company
- Automatic Radio Mfg. Co.
- Carter Genemotor Corp.
- Century Radio Prods. Co.
- Chevrolet Motor Company Consolidated Industries, Ltd.
- Crosley Radio Corp.
- Deico Appliance Corp.
- Detroit Radio Corp.
- Emerson Electric Mfg. Co.
- Fada Radio & Elec. Corp.
- Federated Purchaser, Inc.
- Ford-Majestic
- Franklin Radio Corp.
- Galvin Mfg. Corp.
- General Electric Co.
- General Motors Corp.
- A. H. Grebe & Co.
- Grigsby-Granow Co.
- Chas. Hoodwin Company
- International Radio Corp.
- P. R. Mallory & Co.
- Melborn Radio Mfg. Co.
- Montgomery Ward & Co.
- National Co., Inc.
- Nobilt-Sparks Ind., Inc.
- Phitico Radio & Tel. Corp.
- Pierce-Airo, Inc.
- Premier Electric Co.
- Radio Chassis, Inc.
- RCA-Victor Co., Inc.
- Sentinel Radio Corp.
- Sparks-Withington Corp.
- Stewart Radio & Tel. Corp.
- Stewart-Warner Corp.
- Stromberg-Carlson Tel. Mfg. Co.
- Transformer Corp. of Am.
- United Amer. Bosch Corp.
- United Motors Service
- U. S. Radio & Tel. Corp.
- Utah Radio Prods. Co.
- Wells-Gardner Company
- Wholesale Radio Serv. Co.
- Rudolph Wurlitzer Mfg. Co.
- Zenith Radio Corp.

**\$2.50**

**Over 200 Pages**  
**Over 500 Illustrations**  
**9 x 12 Inches**  
**Flexible, Loose-Leaf Cover**



**MAIL THIS COUPON TODAY!**

**GERNSBACK PUBLICATIONS, INC.** RC-10-34  
 99 Hudson Street, New York, N. Y.  
 Enclosed you will find my remittance of \$2.50 for which please send me One Copy of the OFFICIAL AUTO-RADIO SERVICE MANUAL with FREE 48-page Supplement. Send remittance in check or money order. Register letter if it contains cash or currency. WE PAY POSTAGE.

Name .....

Address .....

City ..... State .....



## A 100-W. AMPLIFIER

(Continued from page 221)

Inherent characteristic of class "B" circuits because the tubes are biased so as to reduce the plate current to practically zero with no grid excitation) is easily attained in this efficient amplifier. Only 120 watts (110 volt A.C.) is consumed under no load conditions, while the power consumption at full load is slightly less than 250 watts. This unusually low current drain (approximately 2 amperes from 110 volt A.C. lines or other power supplying devices) makes this amplifier admirably suited for application in sound trucks, motor boats or aeroplanes wherein a 300 watt 110 volt A.C. output fan belt driven generator, storage battery operated rotary converter or wind driven generator may be employed to provide a suitable source of A.C. power. More than sufficient precautions have been taken (through the use of safety switches, automatic relays, power line fuse, manual switches, high voltage fuse, etc.) to insure thoroughly fool-proof operation and to prevent accidental damage to the amplifier or tubes through careless handling. In fact, the system is so fool-proof and simple to operate that Service Men, radio technicians, dealers, amateurs and even lay operators, with no radio or technical knowledge can satisfactorily set up and easily operate this super-power amplifier. Its overall dimensions are 21 in. long, 11 in. tall, and 10 in. deep. Total weight is less than 58 pounds. This unusual light-weight and compact construction permits it to be easily installed where space or weight is at a premium.

It should be borne in mind that this super-power amplifier was specifically designed to be operated in conjunction with any standard low power amplifier of 5 to 15 watt output employing either a class A, class A' or class B output stage. When it is so used it "boosts" the undistorted audio output power of the "voltage amplifier" up to 100 watts, thereby enabling any such low power amplifier to be used for both low and high power P.A. applications. It is of course understood, that the "voltage amplifier" can at any time be disconnected from the power amplifier and used by itself whenever its own output is sufficient to adequately cover the area involved in any particular P.A. installation.

### Circuit

Although the type 800 tubes were primarily designed for use as radio frequency power amplifiers, oscillators, and modulators, they may also be used to full advantage as class "B" audio frequency amplifiers where large audio power output is required. When two of these tubes are used in a balanced push-push arrangement (Fig. 1) 100 watts of audio power is easily obtained!

While class "B" audio amplifiers are not particularly new, it is entirely befitting to briefly outline the precautions which must be kept in mind during the design construction and operation of Class "B" Amplifier:

First, both halves of the push-push output circuit must be accurately matched inasmuch as each Class "B" tube works for only one-half cycle, it therefore becomes necessary that each output tube should receive exactly the same driving voltage and both should draw equal amounts of plate current under "no-load" conditions. The former condition is met by utilizing accurately center tapped push-push transformers, while the latter is accomplished by strict maintenance of recommended tube voltages.

Second, the plate power supply must have excellent voltage regulation, (better than 5%), which means that in order to avoid any distortion the voltage produced by the power supply system should not change more than 4.5% of the "full load" voltage when operating under "no-load" condition. The use of low resistance windings in the power transformers (PT1, PT2 and PT3) and chokes (Ch1 and Ch2) together with the two mercury vapor rectifiers assure a constant voltage between 1,000 and 1,045 volts from the power supply system.

Third, the driver stage (or voltage amplifier) feeding into this high-power amplifier must be capable of supplying two or three times the actual power required to drive the grids of the 800 tubes. This reserve power is necessary so that the driving voltage shall have good regulation under the variations in load represented by the class "B" grids. For best results, it is rec-

# Webster-CHICAGO

## MICROPHONE MIXING PANEL AND PRE-AMPLIFIER



NO. 104

Ideal for mixing the output of either carbon or condenser microphones and low impedance pick-ups for program work. Three-point polarized plug microphone connections. Remarkable control equipment. Constant impedance controls, high permeability transformers, two-stage pre-amplifier.

### A-C POWER UNIT

Webster W-195 power unit available for AC operation of No. 104 mixing panel. Also direct current for A and B supply of the pre-amplifier as well as button current operation.

### WRITE FOR CATALOG

Let us put your name on the Webster mailing list to receive bulletin on this unit and all our other equipment.

**THE WEBSTER COMPANY, 2880 W. Lake Street Chicago, Illinois**

## The New "DEPENDABLE" TUBE TESTER No. 304

A Sensational Value at \$19.95

Every service man and dealer who has seen it work says, No. 304 is a "Knockout" for simplicity, efficiency, good looks and low price. Tests today's tubes and provides for 50% increase. "GOOD-BAD" meter. Separate line-voltage meter. Automatic Neon-light short and leakage tests (up to a million ohms). Diode and individual tests. Only one button to operate. Compact counter and portable models. Balanced, etched panel. Leatherette case. Complete, only \$19.95. KIT, \$15.65.



Write Dept. RC-10 for FREE Data Sheets

**RADIO CITY PRODUCTS CO., 48 West Broadway, New York City**

## COAST-TO-COAST PRESENTS A FULL LINE OF



## 1935 P. A. AMPLIFIERS

*Never before such features!*

Range in Audio Power Output From 5 Watts to 100 Watts!

Employ an all-steel black crystalline housing with hinged top and ventilating louvres. Available with optional self-contained "Input-Mixer-Fader" Control Panel, Combination Output Meter and "Mike" Current Meter, Self-Contained "Mike" Current Supply, etc., etc.

Models available for operation from either a 6 Volt Storage Battery, or 110 Volt A. C. Universal Models may be operated from both 6 volts D. C. and 110 Volts A. C.

**FREE 100-PAGE RADIO AND AMPLIFIER CATALOG**

Completely describes our new line of 1935 Amplifiers (52 models) as well as All-Wave and Short-Wave Receivers and Converters, Inter-Office Call Systems, Test Equipment, Replacement Parts, Kits, Tubes, and Accessories at unbeatable net prices. Buy direct from the manufacturer and pay only one profit.



**COAST-TO-COAST RADIO CORP.**  
123 K. WEST 17TH STREET, NEW YORK, N. Y.



# Built Especially For Short Wave Work

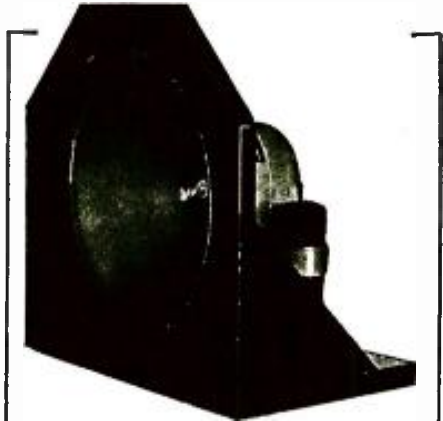

MODEL S.W. 429

The urgent demand by those interested in short wave reception caused us to build this AC speaker which is especially designed for short wave reception. The simple baffle is finished in a deep walnut shade.

Our Engineering Department designed the Model S. W. 429 so that it has very high efficiency and low hum level. Its sensitivity to voice frequencies makes it ideal for short wave work. This new addition to our line of quality speakers merits your consideration. We have made the price of this speaker extremely low considering its excellent quality.

Write for further particulars

**Wright-DeCoster, Inc.**

2251 University Avenue  
St. Paul, Minn.

Export Dept. M. Simans & Son Company,  
25 Warren Street, New York  
Cable Address: Simonrice, New York

## Insist on this Trade Mark

**Radiart**  
TRADE MARK

Exact Duplicate Replacement  
Vibrators for Auto Radios



Every electric auto radio in use means a vibrator replacement eventually. Only with Radiart can you cash in on this market completely. Only Radiart makes a COMPLETE EXACT DUPLICATE line. Only Radiart has the experience of furnishing initial equipment to more than 70% of the auto set manufacturers. Look for the orange and black label on the box and on the vibrator, if it isn't there it isn't a genuine Radiart vibrator. In making replacements choose the vibrator the set manufacturers themselves prefer — you will be sure of a satisfied customer. Available at all good jobbers. Write for catalog sheet.

**THE RADIART CORP.**  
13229 Shaw Ave., Cleveland, O.

If you enjoy reading interesting scientific articles, yet not too technical, you should buy a copy of the current issue of **EVERYDAY SCIENCE AND MECHANICS**—on all newsstands—10c a copy. See special subscription offer on opposite page.

ommended that the voltage amplifier have between 5% and 15% the output of the class "B" stage itself. (Between 5 and 15 watts are therefore required to drive this 100 watt amplifier.)

Although the standard input transformer T1 employed in the amplifier is designed to match the output plate impedance of 2-2A3 tubes operating with a fixed bias, any suitable transformer may be used in its place to efficiently couple the output circuit of any 5 to 15 watt amplifier into the input circuit of this system.

Because of the relatively heavy filament current consumed by the 800 (3.25 amperes at 7.5 volts) it is essential that the socket make a firm and large surface contact with the filament prongs of the tubes; heavy (at least No. 14) well soldered leads should be used for the filament circuit wiring.

An additional precaution to be taken when this amplifier is first set into operation, is to light the filaments of the rectifiers for about one or two minutes before the plate voltage is applied. This should be done to vaporize any of the mercury that may have been spattered onto the filament and plate of the rectifier tubes during shipment.

During periods of intermittent operation, the filaments of the 866's should be allowed to come up to full operating temperature before the plate voltage is applied. Two manual control switches are provided on the front panel for this purpose. The switch on the right hand side operates the bias and filament supply system and should therefore be turned on approximately 30 seconds before the switch on the left side. If the switches should accidentally be turned on in reverse order (i.e. the plate voltage supply first, then the filament and bias supply) the plate voltage will not be applied to the rectifiers and output tubes until the type 80 rectifier is fully heated and sufficient grid bias established to activate the relay (REL) which in turn closes the primary circuit of the plate transformers (PT1 and PT3). The time interval required to operate the relay is more than sufficient to prevent damaging the rectifier or output tubes.

Because of the high potential difference between the grid and plate of the 800 tube (1,055 volts) both of these leads are brought out to metal caps at the top of the bulb. Flexible leads and suitable protected grid clips are used to make connections to both the grid and plate, so that normal expansion caused by heating of the tube will not place any undue strain on the glass at the base of the caps. For similar reasons, the 866 rectifiers are installed in an identical manner. An interesting point to remember about the 866 tube, is that it normally operates with a characteristic blue (ionized mercury vapor) glow and the glass bulb gradually tends to darken. This change however has no detrimental effect on the performance of the tube.

Fig. 1 shows the complete circuit diagram of the 100 watt P.A. amplifier. The pair of 800's operate with 1,000 volts on their plates to produce an honest 100 watts of undistorted audio power. A separate fixed bias filter system composed of PT1, Ch1, C1, R2 and R3 is used to provide a fixed "C" bias of 55 volts to both output tubes. The 2,500 ohm resistors R2 and R3 load the bias voltage supply system so as to provide a constant biasing voltage and eliminate distortion through the grids of the 800's draw current during their positive excursions. Excellent regulation is also obtained in this fixed bias power supply system by utilizing a low resistance choke (Ch3) and three 8 mfd. electrolytic condensers.

The high voltage power supply system uses two special transformers, PT2 and PT3, both of which produce 1,050 volts in their secondaries. These transformer secondaries are connected together in phase with each other (the common terminal is used as a center tap) the outside high potential leads are then connected to the two 866 mercury vapor half-wave rectifiers (which are used to rectify each half of the cycle in a conventional full-wave rectifying arrangement).

The bias power supply transformer (PT1) is equipped with the following three filament and one high potential windings: 7.5 volts, 6.5 amps. for both 800 filaments; 2.5 volts, 10 amps. for both 866 filaments; 5 volts, 2 amps. for the 80 filament, and a 200 volt center tapped winding (40 mils) for the production of a suitable bias voltage.

The 100 ohm choke (Ch2) aids (by virtue of its low D.C. resistance) in the voltage regulation of the high voltage power supply system.

\$3.50  
LIST



## There's plenty of Servicing Material in the 1934 Manual

Radio Service Men and others engaged in various branches of radio know the importance of the GERNSBACK Manuals, and how much they depend on them for reliable information. Whether for public address work, receiver diagrams or tube information, the material needed is certain to be found in one of the volumes of the OFFICIAL RADIO SERVICE MANUAL.

### Contents of the 1934 Manual in Brief

Diagrams and service notes, more complete than ever before in any manual. Voltage readings for practically all sets, as an aid in checking tubes and wiring. All values of I.F. transformers used in superheterodynes, with the manufacturers' own suggestions as to correct balancing. A complete compilation of radio tube data, covering both old and new types. A complete list of American broadcast stations with their frequencies in kilocycles; extremely useful in calibrating test oscillators and receivers. Free question and answer service. No theory; only service information in quickly accessible form. A handy, easily-consulted master index making it easy to find almost anything pertaining to service problems, instantly. This index includes all the diagrams published in all the previous GERNSBACK manuals, as well as the 1934 diagrams. A big convenience and time saver.

**400 PAGES**  
**Over 2,000 Illustrations**  
**9 x 12 Inches**

Flexible Looseleaf Leatherette Cover

**ORDER TODAY!** No need to delay sending us your order—the 1934 MANUAL, like its predecessors, is a necessity in your business. We strongly advise you to order your copy today.

**GERNSBACK PUBLICATIONS, INC.**  
99 Hudson Street New York, N. Y.

-----  
**GERNSBACK PUBLICATIONS, Inc.**  
99 Hudson Street, New York, N. Y.

Enclosed find my remittance of \$3.50 for which send me, Postage Prepaid, One Copy of the 1934 OFFICIAL RADIO SERVICE MANUAL. [Send remittance by check or money order; or register letter if it contains cash, currency or unused U. S. Postage stamps.]

Name .....

Address .....

City ..... State .....

RC-10-34

## TYPEWRITER BARGAIN

New **REMINGTON PORTABLE**

ONLY **10¢**  
A DAY



**TEN DAYS TRIAL**

Only 10¢ a day buys this latest model machine. Not a used or rebuilt typewriter. A beautiful brand new regulation Remington Portable. Standard keyboard. Carrying case included free. Try it in your home or office for 10 days. If you do not agree that it is the finest Portable at any price, return it at our expense. Don't delay.

**FREE TYPEWRITER COURSE**

Mail Coupon Today or Use Post Card

REMINGTON RAND INC.,  
DEPT. 189-10, BUFFALO, N. Y.

Please tell me how I can buy new Remington portable typewriter for only 10¢ a day. Also enclose your new catalogue.

Name .....  
Address .....

## It's Now 10c

EVERYDAY SCIENCE AND MECHANICS is the finest scientific-technical-mechanical-constructional magazine in the field. Up-to-the-minute with news flashes of scientific events. Dozens of constructional articles and many popular experiments. Ideas from which you can make things to sell.

A HOST OF INTERESTING SUBJECTS COVERED:—Woodworking—Photography—Magic—Patents and Inventions—Book Reviews—Metalworking—Chemistry—Engineering—Microscopy—Electrical Experiments—Lathe Operation—Shop Hints and other subjects.



**\$1.00 FOR ONE YEAR**

(Canadian and Foreign \$1.50)  
Send Check or Money Order.

EVERYDAY SCIENCE  
AND MECHANICS

99R Hudson St., New York, N. Y.

Over 150 Illustrations

10c the Copy On All Newsstands

## SEXOLOGY

THE MAGAZINE OF SEX SCIENCE  
SEXOLOGY, foremost educational sex magazine, is written in simple language and can be read by every member of the family. It is instructive, enlightening—not a risqué book—contains no offensive matter.  
Contains 25 important articles on Sex Science. 68 pages, with attractive two-color cover. Here are a few of the more important articles:

What is Sex Morality?—Sex Life of Siamese Twins—“Laboratory Babies”—Eunuchism, or “Lack of Manhood”—The Adolescent Girl—Effects of Pregnancy on Husband—Mother-Son's “Complexes”—Fake Sex Advertising—Cause of Sex Abnormality—Education against Venereal Disease—Syphilis and the Eyes—Sex Adjustment in Marriage—Scientific Sex Notes—Questions and Answers.

SEXOLOGY, 95R Hudson St., New York, N. Y.

Get a copy of SEXOLOGY on any newsstand, or, if your dealer cannot supply you, send 25¢ cash or stamps for current issue.

The bank of 32 mfd. 500 volt condensers (C3) provide an extremely low impedance path to ground for the A.C. component of the rectified voltage. This practically eliminates all traces of residual hum in the power supply system. The 100,000 ohm resistors (R4) stabilize the power supply under “no-load” conditions and also aid in the voltage regulation by increasing the “resting load” of the high voltage plate supply circuit and at the same time evenly distributes the high potential difference across the three condensers which are connected in series to both ends of the high voltage output.

A D.C. milliammeter is placed in the common plate circuit (at the grounded side in series with the filament center top lead) of both 800's so that the total plate current consumed by the output stage is always known. As the normal static plate current is approximately 28 milliamperes (14 mils. for each tube) under no condition should the plate current be allowed to exceed a value 50% greater than normal. (42 mils. with no grid excitation.) In order to prevent tube destruction or transformer burnout, three automatic protective devices are employed in the amplifier, viz:

1. 250 milliamper fuse (F2) in the high voltage power supply.

2. Relay (REL) in the bias circuit which automatically opens the high potential line circuit the moment the bias drops to 80% of its normal voltage.

3. Power line fuse (F1—3 amperes) which automatically disconnects the amplifier from the power line when its power consumption exceeds 300 watts.

A mechanical safety switch (S2) is also employed in the 110 volt power line circuit which shuts off all power the moment the hinged cover is lifted. This safety feature avoids all possibilities of any operator being “kicked” by the high plate voltage applied to the plates of the output and rectifier tubes.

### Output Power Distributor

By careful engineering design and the use of generously built input and output transformers, this “100 Watter” is capable of producing such tremendous and perfectly clear audio power that 60,000 to 75,000 people congregated in outdoor areas (as at airports, auto and horse races, public playgrounds, beaches, etc.) will clearly hear all that is being fed into the input source.

This unusual amount of audio power must of course be distributed over a sufficient number of dynamic or magnetic speakers not only to provide adequate sound distribution, but also to prevent the operation of any particular speaker beyond its normal maximum power handling capacity. The output transformer (T2) is furnished with a 500 ohm secondary (but is also available with any other output impedance value) for standard transmission lines. These lines can be fed into a number of universal line-to-speaker transformers situated at a considerable distance from the amplifier so as to provide a highly desirable degree of flexibility for those who wish to adapt the amplifier to any special installation requiring a large number of remotely placed magnetic or dynamic speakers.

The amplifier System can also be used as a class “B” modulator providing 100% modulation for an input of 200 watts into a class “C” radio frequency amplifier. For this application, however, a special output transformer is required so that the reflected plate-to-plate load impedance is approximately 125,000 ohms. This transformer should be designed with a core sufficiently large to avoid saturation effects which would impair the quality of the output. If the secondary is to carry the D.C. plate current of the modulated amplifier, the core should be made correspondingly larger and include an air gap to compensate for the D.C. magnetization current.

### List of Parts

T1—Remington	Input Transformer	Type
T1-311;		
T2—Remington	Output Transformer	Type
T2-311;		
PT1—Remington	Bias and Filament Trans-	
former Type PT1-311;		
PT2—Remington	Plate Transformer	Type
PT2-311;		
PT3—Remington	Plate Transformer	Type
PT3-311;		

# New RADOLEK 1935

148 PAGE CATALOG  
Is Now Ready

● Listing Over 6000 Parts, Sets, Tubes, Amplifiers, Tools, and Test Instruments Readymade or in Kits.

● Over 200 Diagrams! Complete Volume Control Guide, A New, Modern Tube Index with Bias Resistor Values, Transformer Replacement Data.

● Many New Devices! Exclusive Radolek Inventions in Kit and Finished form.

● Power Amplifiers! As Complete Outfits in Kit and Laboratory Made Units.

● Lowest Prices! High Quality at the Lowest Prices You Have Ever Seen for First Class Merchandise.

● If You've Changed Your Address since receiving our 1933 Catalog, or if you have not received a catalog from Radolek recently, send us your business card or letterhead immediately! Our Catalog Is Strictly Wholesale for Members of the Trade.

**The RADOLEK Co.**

Dept. RC, 609 West Randolph St.  
Chicago, Illinois



**NEW! SHEET METAL PUNCH FOR**

**Servicemen Experimenters! Amateurs**

Knock out those socket and electrolytic holes in METAL chassis easily and quickly in 5 seconds. All you need is a KAY PUNCH and a hammer. Hole sizes: 1/8", 3/16", 1/4", 3/8", 1/2", 5/8", 3/4", 1", 1 1/4", 1 1/2", 1 3/4", 2", 2 1/2", 3", 3 1/2", 4", 4 1/2", 5", 5 1/2", 6", 6 1/2", 7", 7 1/2", 8", 8 1/2", 9", 9 1/2", 10".

**\$1.50** Your price each net, plus postage.

Shp. Wt. 3 lbs. Remit by check or money order for full amount.

**KAY SPECIALTY MFG. COMPANY**

Obtainable in various sizes to meet your requirements 119 S. BROOM STREET MADISON, WISCONSIN

## When Seeking a Radio School . . .

Consider the advantages of RCA Institutes



Whether elementary radio principles or advanced subjects, sound applications or practical radio engineering, RCA Institutes is prepared to give you the instruction you need.

Students attending our Chicago School now have added advantage of combining a study of the scientific wonders of the World's Fair.

**RESIDENT SCHOOLS NEW YORK & CHICAGO** with modern standard equipment

**EXTENSION COURSES FOR HOME STUDY** under convenient “no obligation” plan  
Illustrated Catalog on Request.

**R. C. A. INSTITUTES, Inc.** Dept. RT-34  
75 Varick St., New York—154 Merchandise Mart, Chicago

# FREE-

## YOUR CHOICE OF ONE OR MORE OF THESE POPULAR PREMIUMS



**SHORT WAVE FANS!** Here's a big treat for you—big, valuable premiums given absolutely FREE—many cost several dollars, and which you ordinarily would hesitate buying. Now with each year's subscription to **SHORT WAVE CRAFT**, you get one or more of these attractive prizes. It's an excellent opportunity to get several books or a manual on short waves, one of a variety of beautiful world-globes or a world-time clock—all are available to those who subscribe to **SHORT WAVE CRAFT** on or before October 1st. Mail coupon for complete details.

### A Word About Short Wave Craft

**SHORT WAVE CRAFT** today is the largest, most authoritative magazine of its kind in the world. Its unusual popular monthly radio features make each issue more valuable to short wave fans, hams and experimenters . . . and Service Men as well. **SHORT WAVE CRAFT** is read by nearly 100,000 people. **IT MUST BE GOOD.**

4-Color Cover 9" x 12"—  
Over 200 Illustrations

**25c** The Copy



On All  
News-  
stands

**SHORT WAVE CRAFT** RC-1034  
99 Hudson Street, New York, N. Y.

Send me, gratis, your interesting 4-page brochure, in two colors, which tells about the FREE premiums which you offer with subscriptions to **SHORT WAVE CRAFT**. I understand this subscription offer expires after October 1st.

Name .....

Address .....

City ..... State .....

- Ch1—Remington Choke 500 ohm 30 henrys 60 mils Type Ch1-311;
- Ch2—Remington Choke 100 ohm 15 henrys 250 mils Type Ch2-311;
- C1—Solar 8 mfd. 300 volt Electrolytic Condenser;
- C2—Solar 10 mfd. 75 volt Electrolytic Condenser;
- C3—Solar 3-32 mfd. 500 volt Electrolytic Condenser;
- R1—Centralab 50,000 ohm 2 watt carbon resistor;
- R2—Electrad 2,500 ohm 10 watt wire wound resistors;
- R3—Electrad 2,500 ohm 10 watt wire wound resistors;
- R4—Centralab 100,000 ohm 2 watt carbon resistor;
- S1—S.P.S.T. Switch (Filament and Bias Supply Switch);
- S2—S.P.S.T. Push Button non-locking safety switch;
- S3—S.P.S.T. Switch (Plate Supply Switch);
- F1—3 ampere fuse;
- F2—250 milliampere fuse;
- M—Triplet 250 milliampere fuse;
- REL—Relay 311;
- 1—"Coast-To-Coast" Drilled Chassis and Cover.

## HOW TO USE THE NEW TUBES

(Continued from page 217)

### Power Output Tubes

One finds a great variety of output tubes for use on 2.5 V., while there are comparatively few for 6.3 V. service.

For 2.5 V. service there is the type 45 which is a filament-type triode of medium power output. The type 2A3 is a triode which, in many respects, may be classified as a "bigger and better" 45. In addition to its triode class A service, the 2A3 is used in what is often called class A prime amplification with quite large available output and low distortion. The type 46 is another 2.5 V. filament-type tube which can either be used as a class A amplifier, having somewhat smaller output than the type 45, or in class B amplification with output far in excess of that of the 45s, but with more distortion than in the case of the 2A3's. Type 47 is a pentode tube having greater output than that of the 45 but with the inherent pentode disadvantages, that is, the greater importance of the correct load and somewhat higher distortion level. The 2A5 is an indirectly-heated cathode pentode tube the characteristics of which are the same as those of the 47 and having the advantage over the 47 in that, being indirectly-heated, hum problems are reduced and self-biasing may be effected without having the filament winding at an off-ground potential. This tube is also used as a triode amplifier by connecting the screen grid to the plate, and also as a class A prime amplifier with this same connection, but with different voltages applied. The output in the latter case is comparable to that of the 2A3's. The 59 is an indirectly-heated cathode type tube combining the electrical characteristics of the 47 pentode, 46 triode, and 46 class B. This is accomplished by connecting the 3 grids, which are brought out to separate pins, in the specified manner, depending upon which service is desired.

In the 6.3 V. line we find only 3 tubes which are of the indirectly-heated cathode type. The 42 has identical characteristics to the 2A5. The 41 is a pentode having somewhat less output than the 42 in the pentode connection. The 89 is a combination tube similar to the 59 only on a small scale, having pentode, triode and class B characteristics being accomplished in the same manner, that is, the 3 grids have their leads brought out separately.

Although all the new tubes have been described in **RADIO-CRAFT**, there are a great number of technicians who do not feel "at home" with these multi-element, multi-purpose tubes. To overcome exactly this state of affairs the above article was written; and it is expected that subsequent issues will contain additional articles.

## CLASSIFIED ADVERTISEMENTS

### A. C. GENERATOR

**10 PRACTICAL AND LOW-COST CHANGES** converting Dodge 12-V., Ford T. A., Chevrolet Delco 6-V. generators into 100-500-watt capacity A.C. generators, or into 32-110-V., D.C. motor or generator. Dodge is 500-W. self-exciter. All in one book illustrated with complete simplified instructions and drawings for only \$1. Autopower, 410 S. Horne Ave., Chicago.

### ELECTRICAL SUPPLIES

**INSULATION, WIRE, VARNISHES, SUPPLIES**, etc. Send 3c stamp for bulletin. Autopower, 410 Horne Ave., Chicago.

### PATENT ATTORNEYS

**INVENTORS**—Small Ideas may have large commercial possibilities. Write immediately for free book, "How to Obtain a Patent" and "Record of Invention" form. Delays are dangerous in patent matters. Free information on how to proceed. Clarence A. O'Brien, 533-G Adams Building, Washington, D. C.

**PATENTS—REASONABLE TERMS. BOOK** and advice free. L. F. Randolph, Dept. 562, Washington, D. C.

### PHOTO-CELLS

**"TELEMACH" — STARTLING NEW — ALSO EFFICIENT**, small, bakelite cased photo-cells, \$1.50. Sensitive relays, \$3.00. Circulars free. Send 15 cents for new, valuable pamphlet infrared, ultra violet rays, synchronized photography. Pese Scientific Products, 4918 13th Ave., Brooklyn, N. Y.

### RADIO

**CANADIAN MANUFACTURERS' REPRESENTATIVE** solicits jobber's inquiries on USL Products, REX Condensers, Precision type resistors, Lifetime microphones, etc. Neckrocc, 56 Woodleigh, Hamilton, Canada.

### SHOP EQUIPMENT

**YOU NEED A DRILL PRESS WHEN BUILDING** metal chassis, frames, panels, adapters, etc. Can be used in your laboratory, shop, service bench. Price complete \$17.45—box of drills free—drills to center 9" circle—4 speeds—silent—powerful. Operates on 110 A. C. South Bend Drill Company, 228 Dixie S., South Bend, Indiana.

### TRANSFORMERS

**RADIO TRANSFORMERS, AUDIOS, CHOKES, SPECIAL** transformers, windings. Write for catalog. Dealers wanted. Skiles Transformer Company, California Ave., Fort Wayne, Indiana.



**10 HOURS**  
of Reading Pleasure

### Many Stirring Stories of Future Science in Current Issue

**WONDER STORIES** brings to its readers vivid, thrilling, and absorbing tales of adventure on alien planets—stories of biological monstrosities, time-travel, the future civilizations of man, and other educational science-fiction themes.

Here is the contents for October: **THE THIEVES FROM ISOT** by Eando Binder. **THE FINAL STRUGGLE** by Francesco Bivona. **THE BRAIN OF ALI KAHN** by L. A. Eshbach, and **THE FALL OF THE EIFFEL TOWER** by Charles de Richter (the greatest French science-fiction novel since Jules Verne)—plus several interesting departments and a scientific editorial. The voice of the **SCIENCE FICTION LEAGUE**.

**SPECIAL OFFER** (in U.S.A. only)—One year for \$2.00. Send check or money order.

**WONDER STORIES**, 99-R Hudson St., New York, N. Y.

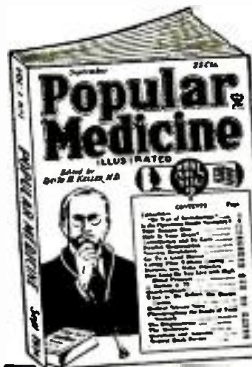

### Be Your OWN Doctor!

This new monthly magazine is also your own doctor. **WHAT AILS YOU? POPULAR MEDICINE** tells and advises you thoroughly. Written for you by doctors. Non-technical, yet authoritative for all laymen. Many anatomical illustrations. At all newsstands.

**Special Offer!**  
**8 Months for \$1**  
Send 25c for sample copy  
**POPULAR MEDICINE**  
97 Hudson St., New York, N. Y.

# AN ULTRA-SMALL SET ANALYZER

(Continued from page 216)

## Choosing the Parts

The choice of parts for the instrument was governed largely by the material already available, so the Service Man should read this article with the thought in mind that the parts used in this particular instrument need not be strictly adhered to. Some of the material will, no doubt, not be readily available, for instance, the material to construct the meter rectifier. This is a minor consideration, however, for good meter rectifiers may be purchased from any good supply house.

To meet the requirement of small size, the whole instrument was assembled on a panel 5 x 6½ ins. It is mounted in a home built carrying case whose outside dimensions are 8½ x 6½ x 3½ ins., which is ample space for the instrument, analyzer plug and cord, battery, adapters and test leads.

All of the meter ranges are brought out to twelve pin jacks, six of which can be seen on each side of the meter. The meter used was a Weston, model 301, 0-1 milliammeter.

The switching system is rather unique, but allows the greatest flexibility with the minimum of space taken up. The switches used were single pole, single throw types, when the circuit is normally closed. When current readings are to be made, a regular phone plug must be used. The leads from the plug are inserted in the proper pin jacks for the ma. range wanted and the phone plug is placed in the jack of the lead in which it is desired to read the current. A feature which is worthy of consideration is that unless the switch is closed to take current readings it is impossible to get a reading on the meter, as the current will pass through the shunts only. This feature eliminates the probability of turning a heavy current through the ma. movement when it is not shunted and burning it out.

## The Sockets

Two sockets are used, a combination 4, 5, and 6 prong socket and a combination small and large 7 prong socket. Wires are run from the socket terminals to the plug-in switches and then to the analyzer plug.

In this particular instrument, much of the apparatus is home-made. The meter rectifier was made from a dry type rectifier taken from an old A.C. dynamic loudspeaker. The plates were cut down to ¼-in. in size and mounted in a small clamp in full-wave line-up, which made a very small rectifier. Separate multipliers, for which carbon resistors were used, were installed for the A. C. voltage ranges and the meter was calibrated against another meter of the proper ranges. Also, the divided shunt was made out of a piece of resistance wire and also calibrated against another meter of the proper ranges.

The ma.-ohms switch deserves special attention. To keep the meter from being shunted all the time, a switch was necessary to open the circuit and leave only the 1 ma. meter in series with the multipliers for voltage readings. Also, when the battery is being used for bias in mutual conductance tube tests, a switch must be provided to isolate the battery from the rest of the circuit. For these uses one of the jacks is altered to make two single-pole single-throw switches on one frame. One of the hard rubber plugs as used in the Supreme 400 series diagnetometer is used to operate this switch. The lower end of the plug is filed to make a half-round plug, which, when inserted in the proper way will close the desired circuit. These two circuits are normally open.

Also, a switch is necessary to remove the rectifier from the meter circuit, otherwise the meter will be shunted all the time by the rectifier, causing incorrect D.C. readings. One of the current reading jack switches, in this case the plate switch, is altered so that when the half round plug is inserted the output of the rectifier unit, R, is then shunted through the meter. This makes this jack also a double single-pole single-throw switch, with the plate circuit normally closed and the rectifier circuit open when the half round plug is not in the jack. Care must

be used to see that the springs on the jack are so bent that when the plug is inserted for plate current readings it does not also close the A. C. switch, for then the meter would be doubly shunted.

As room was not available on the panel, the ohms adjusting rheostat was mounted on a bracket and the shaft extended through the panel. The bracket is held on the panel by one of the tip jack nuts, making one lead from the rheostat. A midget type knob, as used on some of the Philco and Apex sets, was used on this shaft. A 10,000 ohm potentiometer was used for the ohms adjustment, but any of the many well known ohmmeter circuits may be used.

## The Operation

When mutual conductance tests are to be made, two phone plugs are used. The current side of the ma.-ohms switch is closed and the phone jack is inserted for plate current readings. The other phone plug is connected to the battery terminals which are brought out on the panel, and the phone plug is inserted in the jack in which bias is desired. The polarity of this bias voltage may be reversed by simply reversing the two leads from the phone plug in the battery tip jacks.

When a resistance analysis is to be made, the analyzer plug is placed in the proper socket and the ohms switch is closed. The readings between different points in the circuit may be taken by touching the ohmmeter leads to the different points on the circuit where they are brought out on the panel.

Voltage readings are made in the same way. Each prong on the tube socket has its jack switch on the panel, except the filament, whose terminals are brought to two surface type switch points. These are the two points which may be seen directly under the meter. No reversing switch is necessary, for if the meter reads backwards, it is only necessary to change the two test leads to the tip jacks to reverse the reading.

When A.C. voltages are to be read, the half round plug is placed in the plate jack switch so as to close the rectifier circuit to the meter. The test leads are placed in the A.C. pin jacks and the readings made.

One pin jack is provided which places a 0.1-mf. condenser in the circuit for output readings. When output readings are desired, the A.C. switch is closed and one of the output leads is placed in this pin jack and the other in the A.C. pin jack of the range wanted.

Although the writer has developed an extremely compact unit, however, it must be remembered that the instrument described has been designed with special regard for extreme versatility combined with maximum speed of operation; also, these features have been secured at low cost.

Practically all of the parts used in this analyzer were taken from a Supreme diagnetometer which was dismantled, but all of these parts are purchasable on the open market. Listed below are the parts I would use if I were going to build such an instrument and did not have any on hand.

## List of Parts

- One Weston model 301, 0-1 milliammeter, M;
- Five small single circuit closed jacks, Sw. 2, 3, 4, 5 & 6;
- Two small double circuit open jacks, Sw. 1, Sw. 7;
- Three IRC precision wire-wound resistors, R1, R2, R3;
- One 10,000 ohm potentiometer, R-4;
- One Alden combination 4, 5 and 6 prong socket;
- One Alden combination 7-prong small and large socket;
- One Alden 8 wire analyzer cable and plug set with adapters;
- One meter rectifier;
- One Van divided shunt, 10, 100 ma.;
- Two Van meter multipliers for A.C. ranges desired;
- Thirteen small tip jacks, insulated;
- One bakelite panel 5 x 6½ ins.;
- Two phone plugs;
- One pair test leads, with tips;
- Two surface type switch points;
- One small carrying case;
- One ¼-in. hard rubber or bakelite plug (see description).

# FREE LEADING CATALOG For 1935!

Send for the most complete and truly timely book in Radio. It will keep you ahead of the field and save you money. Why buy from skimpy seasonal catalogs whose usefulness is confined to a few weeks—or from books a year old? Write today for radio's most valuable catalog—the ALLIED Radio Guide—always timely because of its remarkable completeness, always up-to-the-minute because of its strategic publication date geared to radio progress.



SEND FOR THIS BOOK

IT WILL SOLVE YOUR RADIO NEEDS AT CONSISTENT SAVINGS!

All-wave and European range sets, battery-transmitting and electric models, Short Wave Transmitters and Receiving equipment—an amazing P. A. listing—test instruments—thousands of replacement parts, tubes and accessories—are packed into the 1935 ALLIED Catalog. Also "Build-your-own" kits. (As kit specialists we can quote for any circuit appearing in any magazine or hand-book.) Write today for your FREE copy of the 1935 ALLIED Catalog.

**Allied Radio**

833 W. Jackson Blvd., Chicago, Dept. D

Please send me your FREE 1935 Catalog

Please quote for Kit described in .....

Name .....

Address .....

City ..... State .....

## HOW TO BUILD, TEST AND REPAIR RADIO SETS



## Radio Construction Library

Including Television, Short-Wave Receivers and Auto Radios, 3 Volumes, 6x9—1177 pages, 561 Illustrations

This practical Library includes: PRACTICAL RADIO—The fundamental principles of radio, presented in an understandable manner, illustrated with working diagrams. PRACTICAL RADIO CONSTRUCTION AND REPAIR—Methods of locating trouble and reception faults and making workmanlike repairs. Discusses modern Short-Wave Receivers and installation of automobile radios fully. RADIO RECEIVING TUBES—Principles underlying the operation of all vacuum tubes and their use in reception, remote control and precision measurements.

Helps you to understand modern type receiving sets—full of construction data and practical kinks for the experimenter—a training course for service men.

10 Days' Free Examination  
Easy Terms

McGraw-Hill

## FREE EXAMINATION COUPON

McGraw-Hill Book Company, Inc.,  
330 W. 42nd St., New York.

Gentlemen:—Send me the new RADIO CONSTRUCTION LIBRARY, all charges prepaid, for 10 days' Free Examination. If satisfactory I will send \$1.50 in 10 days, and \$2.00 a month until \$7.50 has been paid. If not wanted I will return the books.

Name .....

Home Address .....

City and State .....

Position .....

Name of Company .....

- - ahead of others

# in TUBE TESTER Value

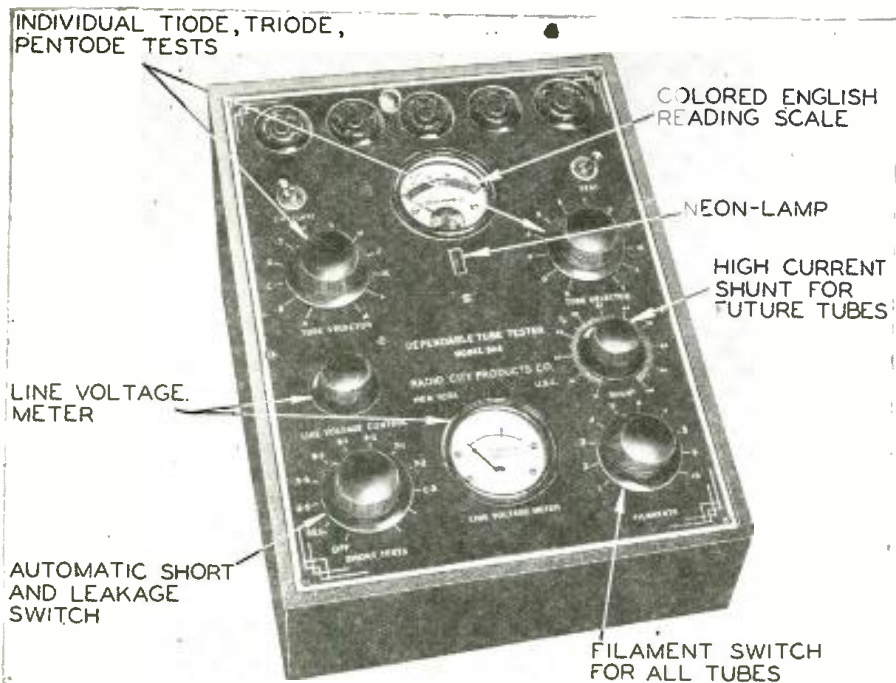

## 12 Outstanding Features!

- 1-ENGLISH READING Scale — COLORED DIAL indicates "GOOD-POOR-?"
- 2-TESTS EVERY TYPE of tube made to-day and many new ones which shall arrive in the future.
- 3-TESTS SHORTS and LEAKAGES between ANY TWO elements.
- 4-NEON LIGHT indicates leakages above 1,000,000 ohms.
- 5-SEPARATE LINE VOLTAGE meter with line voltage control.
- 6-INDIVIDUAL TESTS OF DIODE, triode, pentode, etc., sections of all combination-type tubes—both plates of all full-wave rectifiers.
- 7-PROVIDES AGAINST OBSOLES-CENCE—Spare switching capacity for three times the present number of tubes.
- 8-SIMPLE TO OPERATE; convenient to use.
- 9-PROFESSIONAL APPEARANCE — etched panel; leatherette case.
- 10-ACCURATE D'Arsonval moving-coil meter, guaranteed 2% accuracy.
- 11-NO ADAPTERS of any kind necessary.
- 12-ECONOMY—Costs less than other testers that do not have all these features.

The new, Model 304, Dependable Tube Tester establishes a new "high" in test equipment to meet all modern requirements in testing. Simplicity in design and operation permit even the average consumer, who knows very little about radio technicalities, to follow the testing procedure, and to accept without further question the "good" or "bad" evaluation of every tube in the set.

Dependable Model 304—100-135 volts; 50-60 cycles

NET TO DEALERS

**\$19.95**

(25 cycle—\$2.25 extra)

### KIT FORM

In kit form—"to build your own" Model 304 Dependable Tube Tester—with all instructions. **\$15.65** NET TO DEALERS ..

### MODEL 304

*Dependable Tube Tester also in Portable Model*

There is an important economy factor in purchasing a Model 304 Dependable Tube Tester. The instrument is capable of making all essential tests, and because it is portable may be taken from store or laboratory and used on outside service calls. In addition it has a handy compartment for small tools.



**Combination Portable Carrying Case for Model 304**  
—illustrated—\$2.25 additional.

## 2,000 OHMS PER VOLT MULTITESTER

A high-quality test instrument. The moving-coil instrument sensitivity is 2,000 ohms per volt. This instrument meets 4 major specifications. Ohm-meter range: ¼-ohm to 2 megs.; individual range: 0-2,000 (ohms)—0.2 (-meg.) -2 (megs.), (batteries, self-contained). Voltmeter range: 0-5-50-250-750 V. Milliammeter ranges: 0-50 ma. Microampere range: 0-500. The automatic selector switch connects the meter only to the desired circuit and range.

Net to Dealers .. **\$14.95**



**KNOCK-DOWN KIT—Model 403K**  
Complete with instructions (less batteries and case), NET TO DEALERS ..... \$10.95

### WE ISSUE NO CATALOG

All orders are F. O. B. New York. Terms: A deposit of 20% is required with every order. Balance may be paid on delivery. Deduct 2% if full amount is sent.

## GREN PARK COMPANY

101 Hudson St.

Dept. RC

New York, N. Y.

● Index to Advertisers ●

<b>A</b>	
Aerovox Corporation .....	246
Alan Radio Corp. ....	236
Allied Engineering Institute .....	244
Allied Radio Corp. ....	281
Amperite Corporation .....	253
<b>B</b>	
L. Mitchell Barcus .....	240
Bud Speaker Company .....	234
<b>C</b>	
Capitol Radio Engineering Institute ....	240
Central Radio Laboratories .....	232
Classified Section .....	250
Coast-to-Coast Radio Corp. ....	247
Cornish Wire Company .....	244
Coyne Electrical School .....	193
<b>D</b>	
Tobe Deutschmann Corporation .....	238
<b>E</b>	
Electrad, Inc. ....	236
<b>F</b>	
Freed Radio Company .....	244
<b>G</b>	
General Transformer Corp. ....	245
Goldentone Radio Company .....	242
Grenpark Company .....	252
<b>H</b>	
Hammarlund Mfg. Company .....	245
Harrison Radio Company .....	244
Hygrade-Sylvania Corp. ....	239
<b>I</b>	
International Resistance Co. ....	243
<b>J</b>	
Jensen Radio Mfg. Co. ....	238
<b>K</b>	
Kay Specialty Mfg. Co. ....	249
<b>L</b>	
Arthur H. Lynch, Inc. ....	253
<b>M</b>	
McGraw-Hill Book Company .....	251
Midwest Radio Corp. ....	Back cover
<b>N</b>	
National Radio Institute .....	195
National Union Radio Corp. ....	235
<b>P</b>	
Pioneer Sound Laboratories .....	242
Popular Book Corp. ....	250
Popular Medicine .....	250
Postal Radio Corp. ....	253
Powerack Company .....	243
Presto Recording Corp. ....	238
<b>R</b>	
Radiart Corp. ....	248
Radio Amplifier Laboratories .....	232
Radio City Products Company .....	247
Radio Trading Company .....	256
Radio Training Association .....	234
Radio & Electrical Exposition .....	Inside back cover
Radolek Company .....	249
Raytheon Production Corporation .....	233
RCA Institutes, Inc. ....	249
RCA-Victor Company .....	236
Readrite Meter Works .....	237
Remington Rand, Inc. ....	249
<b>S</b>	
S. O. S. Corporation .....	246
Servicemen's Pub. Company .....	253
Sexology Magazine .....	249
Shallcross Mfg. Company .....	242
Shure Brothers Company .....	240
Solar Mfg. Company .....	234
Supreme Instruments Corp. ....	Inside front cover
<b>T</b>	
Triplett Electrical Instrument Co. ....	241
Try-Mo Radio Corp. ....	246
<b>V</b>	
Van Leuven Laboratories .....	246
<b>W</b>	
Webster Company .....	247
Wellworth Trading Company .....	255
Weston Electrical Instrument Corp. ....	231
Wholesale Radio Service Co. ....	242
Wright-DeCoster, Inc. ....	248

(While every precaution is taken to insure accuracy, we cannot guarantee against the possibility of an occasional change or omission in the preparation of this index.)

READERS' DEPARTMENT

(Continued from page 226)

onating the antenna for most effective reception of the shorter wavelengths generally 'flat' sensitivity is obtained, in many instances due to the increase in sensitivity with an increase in wavelength of the average radio set." Again the exact opposite is true.

An antenna, for best results, should resonate at the longest wavelength to be received, higher frequencies being received quite efficiently. And most sets become more sensitive at the low wavelength of the dial, not the high.

Again, on page 108, it is intimated that the Stromberg-Carlson receiver is designed for use with four separate antenna systems. In reality it is used with simply a doublet and a long-wave antenna. The author has read his circuit diagram incorrectly.

H. XIQUES.

198-19 Hillside Ave.  
Hollis, Long Island

These interesting comments by Mr. Xiques have been brought to the attention of the author, who advises as follows:

In a short article it is difficult to do justice to the extensive subject of radio antenna design. For this reason many statements were made without explanation in the two-part article, "Important Facts About the New All-Wave Antenna Systems," which appeared in the July and August, 1934, issues of RADIO-CRAFT. It is for this reason that we welcome this opportunity to clarify seemingly ambiguous statements made in the article, as mentioned by Mr. Xiques.

Referring to Fig. 2, page 85, it may be remarked that a "lead-in strip" is not at all particular whether one end of it terminates at the antenna or the ground post of a radio set. Philco engineers, after several years' experience, recommended a "straight-through" arrangement of the antenna, from its far end to the radio set, as illustrated and described.

Under the sub-heading, "A High-Quality Doublet Antenna System," appears the statement, "However, the trick is to keep the two down-leads as far apart as possible, within reasonable limits, if the shortest wavelengths are not to be too greatly attenuated." Although this statement was understood to be correct at the time it was originally written, subsequent research by Arthur H. Lynch, Inc., has shown that the two down-leads should be as close together as possible—except where the lead-in is matching into a high-impedance system (as for instance an L-type antenna). The trick is to match the impedance of the lead-in to that of the antenna. Now, inasmuch as a doublet has an impedance of about 70 ohms (at the frequency for which this figure is taken) and a lead-in of the transposition-block type has an impedance of over 400 ohms, the mis-match is evident. A transposition-cable type of lead-in using varnished cambric wrapping in place of rubber, around the two conductors, on the other hand has an impedance of about 70 ohms, which is a perfect match for the doublet antenna.

The statement on page 107 which reads, "By resonating the antenna for most effective reception of the shorter wavelengths, generally 'flat' sensitivity is obtained, in many instances," is not the result of guess-work or heresy. Bertram M. Freed, in checking the performance of a great number of all-wave installations, including home antennas, and store demonstrator antenna systems operating under the most adverse conditions, has proven the point by actual experience. The fact does not hold in every case, but, where the radio set is of modern type incorporating improved circuit design, it is not unusual to find greatly increased set-sensitivity at the high-wavelength end of the tuning scale, "—in many instances," as stated. This condition serves to counterbalance the lower high-wavelength efficiency of an antenna system resonated at the shortest wavelength.

On page 108, the last paragraph reads, "When two antennas are installed as described above, the operation of the range switch automatically connects the proper antenna for the desired range." That is, a long and short L, short L and doublet, or long L and doublet antenna arrangement may be used; the desired combination of 2 aerials is then automatically selected to best advantage when the range switch is operated.

DON'T BUY ANY ANTENNA SYSTEM

before getting details of the two new patented and guaranteed LYNCH "HI-FI" ANTENNA SYSTEMS (High Fidelity)

Reception completely revolutionized on wave lengths from 3 to 650 meters. It's fun to be fooled—but it's more fun (and better business) to KNOW. Investigate before you buy.

At Leading Radio and Dept. Stores, or Write Us for Full Details

ARTHUR H. LYNCH, INC.  
227 Fulton St., New York, N. Y.

LIFELIKE REPRODUCTION

WITH THIS SUPERIOR MIKE

Amperite Model RA-1 gives you clear, faithful reproduction... Speech and music delivered as distinctly as rendered by the performer. What an amazing contrast to the distorted, hissing, "screened" performance, given by inferior and old style mikes! Flat response over entire audible range... Directional quality eliminates acoustical feedback... Frequency response 42 to 10,000 CPS. Output -90 decibels. Output impedance 50 and 200 ohm. Order from wholesaler today.



AMPERITE Corporation 547 57th St. N. Y. C.

AMPERITE VELOCITY MICROPHONE

ACTUAL TROUBLES IN COMMERCIAL RADIO RECEIVERS

By Bertram M. Freed

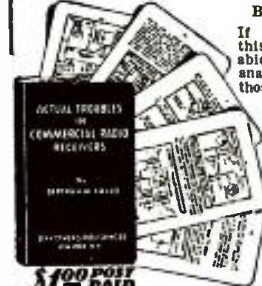

If you are a serviceman this book can be as valuable to you as your set analyzer. It points out those faults that the analyzer cannot detect. Over 500 model sets treated with 47 diagrams. A compilation from thousands of actual records on which the author with the co-operation of several service organizations throughout the country, spent many months at work.

FREE TRIAL

Money refunded within 10 days if you do not think this book is worth one dollar.

INCLUDES FREE SUPPLEMENT

Servicemen's Pub. Co., 136 B Liberty St., N. Y. C.

NEW SERVICEMEN! Something NEW in P.A. SYSTEMS!

DEALERS! Servicemen! Make big money renting or selling the new Postal All Purpose P. A. System. Simple to Install. Extremely low in cost. Write for free descriptive circular.

POSTAL RADIO 135-K LIBERTY ST. NEW YORK, N.Y.

# SERVICE MEN'S ESSENTIALS FOR ALL MEMBERS OF THE ORSMA

## WHAT ARE THE SERVICE MEN'S ESSENTIALS?

THE OFFICIAL RADIO SERVICE MEN'S ASSOCIATION has arranged to supply a number of "Service Men's essentials" for its members and associate members only.

These essentials are priced at cost, plus a small additional fee which is the only source of income that the Association has. No one obtains any profit or benefit, except the Association itself. Whatever profit accrues, is reinvested for the furtherance and enlargement of the Association.

By using the letterheads, billheads, etc., you present the business-like appearance to your customers. In addition, the Association has made arrangements with most of the prominent manufacturers to allow special discounts to members, providing ORSMA letterheads are used when ordering.



No. 14—50c each  
(Plus 10c for Postage)

### No. 1 ORSMA LETTERHEADS

These letterheads, shown on the right, are furnished with your name, address and telephone number. Printed on excellent Paper. They are sold in lots of 100 or multiples thereof, with a distinct saving for single orders of 1,000 or more. Per 100, 60c; per 1000, \$3.00.

### No. 2 ORSMA ENVELOPES

These are furnished to match the letterheads, printed with your name and address and seal of the Association. They go hand in hand with the letterheads and are usually ordered in the same quantity. Per 100, 60c; per 1000, \$3.00.

### No. 3 ORSMA SERVICE RECORD CARDS

These serve a double purpose; whenever you complete a job you fill out the report-bill and hand it to the customer; this is the "psychological moment" to collect. By the use of carbon paper a permanent record is kept. Furnished with name, address and telephone number. Per pad of 50, 60c; per 10 pads, each of 50, \$3.00.

### No. 4 ORSMA INSPECTION LABELS

The label is to be filled in with the proper dates, and pasted inside the set or cabinet where the customer will see it. It is a continuous reminder to him that when service is needed, he can call you again. The advantage is apparent. Per 100, 60c; per 1000, \$3.00.

### No. 5 ORSMA LAPEL BUTTON

At the suggestion of many members a handsome lapel button bearing the name and emblem of the Association has been designed. It signifies that you belong to the ORSMA; and in addition it gives your customers a better appreciation of the professional nature of your work. 50c each.

### No. 6 ORSMA BUSINESS CARDS

These are furnished on a fine grade of paper in two colors with a blotter back. Thus they present an incentive to customers to keep them in a prominent place. They are printed with your name, address and telephone and bear the official seal of the Association. Per 100, 75c; per 1000, \$4.00.

### Nos. 9 & 10 ORSMA EMBLEM CUTS

These cuts for printing, advertising, etc., are furnished in two styles and sizes. They may be used for newspaper or telephone-book advertisements or for printing of any kind. Large size, 1 1/4 x 1 1/4 in., \$1.35 each; small size, 3/4 x 3/4 in., \$1.20 each.

### No. 11 ORSMA MEMBERSHIP SIGN

A set of three signs, printed on heavy cards, and having holes punched in order to hang in office or store. These are sold to members and associate members. Large enough to be quite prominent and the two tone effect makes them attractive. Set of three, 50c.

### No. 12 ORSMA ADVERTISING DISPLAY SIGN

A two color sign printed in large letters with your name, address and telephone, with the seal of the Association. This sign is sold in quantities of 25 or more and is ideal for hanging in stores, offices, etc., for advertising purposes. Set of 25 cards, \$3.00.

### No. 13 RADIO SERVICE MEN'S ASSORTMENT PACKAGE

This includes one gold filled lapel button, 100 letterheads, 100 envelopes, 50 service record cards, and 100 labels printed with your name and address as described above. The whole assortment costs only—\$3.00—a worth-while saving. Complete, \$3.00.

### No. 14 ORSMA MEMBER CERTIFICATE

A handsome diploma-like certificate engraved on stiff vellum-bond. The certificate is personally signed by the President and Executive Secretary and the corporation stamp of the Association is impressed on a red seal attached to it. Your name, certificate number and date of registration are lettered by hand and the Certificate is mailed in a cardboard tube to insure safe delivery. Each 50c, plus 10c for postage.



No. 1—60c per 100  
\$3.00 per 1000

No. 3—60c per pad of 50  
\$3.00 per ten pads, each of 50



No. 5—50c each

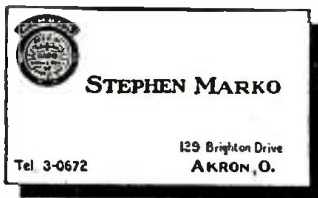

No. 6—75c per 100  
\$4.00 per 1000



No. 4—60c per 100  
\$3.00 per 1000

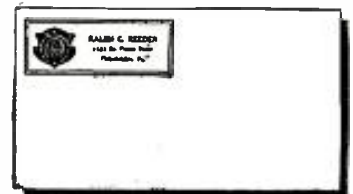

No. 2—60c per 100  
\$3.00 per 1000

## Application for Membership in ORSMA

Executive Secretary, ORSMA  
99 Hudson Street, New York, N. Y.

Kindly send an application blank for

- Full Membership  
 Associate Membership

Name .....

Street or Box .....

City..... State.....

RC-1034

## OFFICIAL RADIO SERVICE MEN'S ASSOCIATION

RC-1034

99 Hudson Street, New York, N. Y.

Please send me the following RADIO SERVICE MEN'S ESSENTIALS which I have selected from this advertisement. My remittance for \$..... is enclosed. Send remittance in form of check or money order. Register letter if it contains cash, currency or unused U. S. Postage Stamps.

.....  
.....  
.....

Name ..... ORSMA No. ....  
Address ..... City and State .....



# BARGAINS

All Merchandise Offered On Page  
Is Absolutely New And Unused

HERE IS A GREAT VALUE!

## Electrical Portable Sprayer Outfit

**\$27<sup>50</sup>**  
COMPLETE

Formerly sold for \$68.50

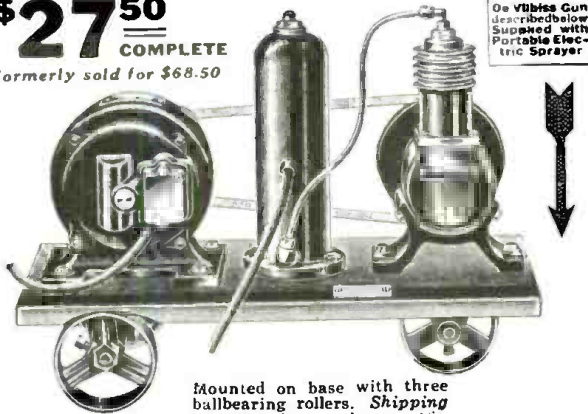

De Vilbiss Gun described below Supplied with Portable Electric Sprayer

Mounted on base with three ballbearing rollers. Shipping weight of complete outfit, 55 lbs.

This is the ideal outfit for all-around spraying work wherever current is available. With this electric sprayer you can spray paint, varnish, duco, enamel, lacquer, insecticides, etc., with speed. You can move it from one room to another with ease. Simply insert plug into electric socket and this marvelous machine is ready to do a man-size job—and do it efficiently.

This electric portable sprayer saves its cost over and over again on your own work. It will make money for you doing jobs for others.

Outfit equipped complete with De Vilbiss Gun, Universal head, with quart aluminum cup, which enables you to obtain round or fan spray.  $\frac{1}{4}$  H.P. heavy duty motor, 110-volt, 60-cycle AC, air filter, safety valve, Kellogg Air-Cooled Compressor,  $1\frac{1}{2} \times 1\frac{1}{2}$ , 15 feet of hose, cord and plug. Pint mason jars can be used on gun for extra containers. Furnished with 50 lbs. pressure tank.

Price of complete outfit with gun, \$27.50  
Price of outfit without motor, \$20.00

## De Vilbiss Spray Gun

**\$5<sup>95</sup>**

A fast suction-feed attached cup spray gun for use with low pressure compressing units of small displacement. Operates from 20 to 50 lbs. pressure, produces fan spray 5" in width. Tip adjustable for either round or flat spray. Material flow control, will spray lacquer, enamel, paint, varnish, and duco. Produces smooth, even finish. Displacement 2 cu. ft. per minute, equipped with aluminum quart cup. Pint glass mason jar can be used for extra container.

Shipping weight, 3 lbs.



Big Bargain

## Filter Tank \$4<sup>25</sup>

Complete with tank, gauge and 60 lb. safety valve

Compressed air filter and expansion tank, equipped with gauge and safety valve. Has standard taps in tank and base ready to install. Eliminates oil and moisture.

Same as illustrated in Electric Portable Sprayer Outfit shown above.  
Shipping weight 8 lbs.

## Kellogg Air-Cooled Compressors at less than half price!

Same as illustrated in Electric Portable Sprayer Outfit shown above.

Size	Maximum Pressure	Speed	Motor	Price
$1\frac{1}{2} \times 1\frac{1}{2}$	75 lbs.	600	$\frac{1}{4}$ H.P.	<b>\$7.50</b>
$1\frac{1}{2} \times 2$	100 lbs.	600	$\frac{1}{4}$ H.P.	<b>9.00</b>
$2 \times 2$	125 lbs.	600	$\frac{1}{3}$ H.P.	<b>10.50</b>
$2\frac{1}{2} \times 2$	175 lbs.	500	$\frac{1}{3}$ H.P.	<b>12.50</b>

Shipping weight, 12, 13, 14, and 18 lbs.

## ORDER FROM THIS PAGE

Since We Do Not Publish Any Catalog

Remit by check or money order for full amount of each item—shipped by express collect, if no money for P.P. enclosed. No C.O.D. order accepted. Money refunded if not satisfied. Be sure to state shipping point if express or freight office is not in your town.

**WELLWORTH TRADING CO.**

560 West Washington St.

Chicago, Ill.

## G. E. MOTORS

These Motors were manufactured by the General Electric Company and originally intended for use by a large manufacturing company.

Here are the specifications: 1/30 h.p.—1800 R.P.M. Universal A.C. and D.C. 110 volts instant reverse. Size: Diameter 3 inch, length 5 inch. Shipping weight, 3 lbs. Add 23c for special packing and mailing anywhere in U.S.A.

**\$2<sup>45</sup>**  
EACH

WHILE THEY LAST.



Original Price \$12.00

## HEAVY DUTY Electric Drill $\frac{3}{8}$ in.

**\$14<sup>95</sup>**

Shipping weight, 7 lbs.

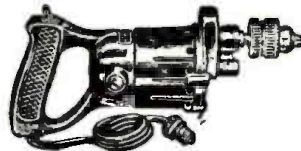

WEIGHT—6 pounds, perfect balance.  
CAPACITY— $\frac{3}{8}$  inch.  
MOTOR—Westinghouse Universal, specially constructed for this drill, 110 volts, DC, or 60 cycle, AC.  
BODY—Aluminum.  
FIRE SPEED—2,000 revolutions per minute. Full load speed, 850 RPM.  
GEAR REDUCTION— $7\frac{1}{2}$  to 1.  
BUSHINGS—Special high-grade bronze.  
GEARS—Nickel alloy steel and high-grade bronze.

### SPECIFICATIONS

VENTILATION—Forced, around field and armature.  
SWITCH—Normally open, quick break. Designed for this drill. Approved by Underwriters.  
CHUCK— $\frac{3}{8}$  inch—keyless.  
LENGTH—Over all, 12 inches. All parts interchangeable.  
Equipment complete with chuck, 7-foot rubber-covered cord and steel-armored, unbreakable attachment plug.

## Westinghouse Power Generator

Manufactured by Westinghouse for U. S. Signal Corps.

Built-in commutator takes off the generated D. C. Three leads extend through the casing to permit a  $4\frac{1}{2}$  V. flashlight-type battery to be switched into circuit for starting, and to control the A.C. output. Rotated at its normal speed of 4,500 r.p.m., the output is 200 W. at 115 to 125 V. (on open circuit), 900 cycles. The rotor turns in ball bearings. Shaft length (driving end), 2 ins.; diameter 9/16-in.; the end is threaded for a distance of  $\frac{3}{4}$  in. Base dimensions exclusive of the shaft,  $4\frac{1}{2} \times 6\frac{1}{2}$  in. in diameter. Guaranteed new and perfect.

### Here is what one of our customers writes:

"These generators are being used in a small fishing village, where the only current is supplied from a 2K.W.-D.C. generator. As it was impossible to use A.C. sets and especially my short wave transmitter using two 45 tubes, one of the generators is used to supply my two A.C. receivers and the other to supply power for the transmitter. Both generators are run by a  $\frac{1}{4}$ -horsepower motor. These generators perform perfectly and have been absolutely trouble free. The voltage and current regulation is remarkably stable, taking a considerable overload."—(Name supplied on request.)

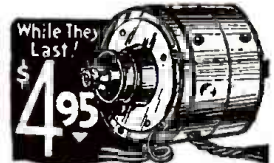

Shipping weight, 13 lbs.

## G. E. Phonograph Motor

Variable speed induction type self-starting, 110 volt, 60 cycle, AC, with lever control. Speed range from 5 to 200 RPM. Can be installed in place of old-fashioned, hand-winding speed motor. Also ideal for display turn table, and a hundred other uses. These G.E. Electric Motors are brand new, in original factory cartons. Same motor that formerly sold for \$15.00.

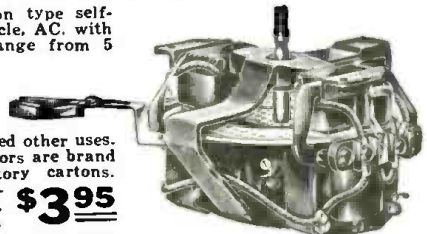

Complete with speed regulator (not shown in above picture).  
Shipping weight, 11 lbs.

Formerly Sold for \$15.00

WELLWORTH TRADING CO.  
560 West Washington St., Chicago, Ill.

RC-10

I enclose \$..... for which please send me the following:

Name .....

Address..... City..... State.....

# RTC's Big October SPECIALS

## YOUR DOLLAR— IS WORTH MORE

When You Buy From Us

Is the dollar inflated? These days everybody is speaking of inflation, but why worry about it, whether the dollar is inflated or not, it is worth more when you buy from us. The prices shown on this page are so radically low that no one can possibly undersell them. Our consistent advertisements present to you each month, on this page, certain STAR (\*) items which are not listed in our regular catalog. These are all specials of which the small quantity on hand does not permit us to catalog them. **ONCE SOLD OUT NO MORE CAN BE HAD AT ANY PRICE. ORDER TODAY—NOW.** Order direct from this page and save money. 100% satisfaction guaranteed on every transaction.

We are a wholesale house and cannot accept orders for less than \$3.00. If C.O.D. shipment is desired, please remit 20% of the total amount of your order. Balance will go forward C.O.D. If full cash accompanies your order deduct 2% discount. Send money order, certified check or U. S. stamps.

Be sure to include sufficient extra remittance if order is to be shipped via parcel-post; any excess will be refunded.



**FREE**  
**RADIO**  
and  
**Short Wave**  
**TREATISE**  
—  
**108 Pages**  
**1500 illus.**

Completely revised and enlarged, this new 1934 edition contains 108 solid pages of useful radio information, diagrams, illustrations, radio kinks and real live radio merchandise. It contains more valuable radio information—more real live "meat"—than many text books on the subject. **PARTIAL LIST OF CONTENTS:** Fundamental Principles of Radio for the Beginner, Chapter 2—Fundamental Circuits and Uses of New Tubes—Re-wiring Six-Volt Battery Sets for Two-Volt Tubes—Public Address Systems—How to Build Short-Wave Transmitters and Receivers—Up-to-Date Tube Chart and Socket Connections, etc., etc. **WRITE TODAY**—Enclose five cents (coin) for postage. Treatise sent by return mail. Print name and address clearly on request.

## BIG 8-TUBE SET BARGAIN

★ Complete with 11" Dynamic Speaker

Limited Supply

**\$13.94**  
only

"THE GREATEST SET BUY IN AMERICA" is by all means a mild description of the value which we are offering here. This very same 8-tube receiver as recent as eight months ago, sold for more than \$95.00, yet now, because of the advent of even later type tubes, you can purchase this receiver for only a small fraction of that price. The tubes employed in this set are still comparatively new; and not only that, but all modern features such as 2A5 parallel output, tone control, phonograph attachment provisions, full dynamic speaker, etc., are incorporated.

The selectivity and sensitivity of this 8-tube receiver, due to its 4 tuned stages, are just as sharp as those of an 11-tube superheterodyne. The construction of the set is best described as "standard," for its circuit is none other than the "good old stand-by" T.R.F. type modified and improved to use these later type tubes. It incorporates 3 stages of tuned R.F. amplification, using type 58 triple grid tubes; followed by a 56 detector. From there the signal is amplified by a type 56 first audio tube, and from there still further amplified by the powerful push-pull 2A5 power output tubes. By the time the signal comes out of these tubes, it is strong enough to operate 4 or 5 dynamic speakers very easily, and many times that number magnetic speakers. A type 80 full-wave rectifier is employed. All provisions for supplying field power to the 11" genuine Oxford dynamic speaker, is incorporated.

Tuning is extremely simple and very sharp, being comparable to the tuning of a superheterodyne receiver. A new type travelling "ghost light" is employed. The three controls on the front of the chassis consist of tuning knob, tone control knob and volume control, respectively. The chassis itself is made of heavy steel, beautifully black enameled. All tuned circuits are thoroughly shielded, including the tubes and condensers. This prevents feedback, whistling and howling. The use of 4 tuned circuits employing the new triple grid, screen grid tubes and high gain R.F. transformers, together with careful wiring



*Not a Midget!*  
but a full-sized CONSOLE CHASSIS

and by-passing, results in extremely high sensitivity. Many of our satisfied customers inform us that a good variety of distant stations come in regularly like locals. And why shouldn't they, for 4 tuned stages is more than what even more recent sets are employing, and everyone knows that the more tuned stages you have the greater is the sensitivity and particularly the selectivity of a receiver. Tone quality, too, is extremely fine and can be controlled to suit the individual, from very high treble down to deep bass. Tuning range 214 to 600 meters.

Here is an opportunity for wide-awake servicemen to "clean up." There are little more than 150 of these excellent chassis available, hence "first come, first served." Judging by the rapidity with which our "Peerless" receivers sold a few months back, when we had a sale on them, the supply of these considerably superior receivers will not hold out very long. The moral is, "Don't delay, order today." Overall size of chassis, 15 1/2" x 11" x 8 1/2". Shipping weight, 40 lbs.

List Price \$95.00

No. 2008—8-Tube T.R.F. Receiver, Including Dynamic Speaker But Less Tubes **\$13.94**  
YOUR PRICE .....

TUBES: 3 58's, 2 56's, 2 2A5's, 1 80.....\$6.30

## FAMOUS "19" TWINPLEX KIT

For Short-Wave Foreign Reception

15-550 Meters

Economical  
**2-VOLT**  
OPERATION



**ONLY \$4.95**

with  
Earphone  
and Two  
Plug-in  
Coils  
Less Tube

The TWINPLEX is ACTUALLY A TWO-TUBE SET; yes, we repeat. A FULL-FLEDGED TWO-TUBE SET AT THE PRICE OF A ONE-TUBE SET. JUST IMAGINE, TWO TUBES IN ONE GLASS ENVELOPE. That is the story of the new "19" tube. It is a 2-volt tube, which has a DOUBLE SET OF ELEMENTS. The "19" TWINPLEX is available ONLY in kit form. Shipping weight 5 pounds.

No. SW-308 Famous Twinplex Short-Wave Receiver Kit with all parts INCLUDING SINGLE HEADPHONE AND BAND—But no tube **\$4.95**

YOUR PRICE  
No. SW-308 Complete Accessories for TWINPLEX Receiver, Comprising 1 Type "19" Tube, 2 No. 4 Dry Cells, 2 45-volt "B" Batteries. Shipping weight 20 pounds. **\$3.55**

YOUR PRICE  
Additional Plug-in Coils for the 20, 80 and 160 meter bands—45c each.

## PHOTOPHONE-TYPE Theatre Dynamic

15" Cone—18 Watts



A Photophone-type dynamic speaker capable of handling up to 18 watts, undistorted, and having a top "push" test of 25 watts. Ruggedly constructed, with chamomile-floated, 15" corrugated cone and Grandee three-point outside spider. The heavy duty field alone weighs 8 1/2 lbs. The entire net weight of speaker is 35 lbs. The speaker reproduces all audio frequencies without discrimination. This is the first time that a photophone-type dynamic reproducer is being offered for less than \$45.00. Its original list was \$100.00. The speaker is available with any desired field specifications including the 6-volt type. Does not include output transformer. Shipping weight 40 lbs.

No. L-1 Photophone-Type Dynamic Speaker **\$17.95**  
YOUR PRICE .....

## 3-STAGE 20-WATT CLASS "B" KIT

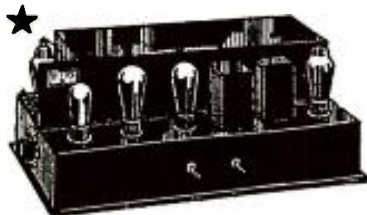

Save \$8.00  
Assemble It  
Yourself

No. 46K Kit less tubes **\$29.95**  
No. 46W Wired, **\$37.95**  
less tubes .....

Here is a splendid opportunity to buy a real, professional amplifier at a substantial saving. There are only 20 of these fine public address

units available—all in kit form. Assembly, with the aid of simple instructions, is a simple matter. However, we'll build it for you, if you wish, at a charge of \$8.00. You save that amount if you assemble it yourself. The amplifier uses 1-57, 3-46's and an 82 rectifier. Input to grid of 57; output impedance 4000 ohms. Ship. wt. 45 lbs. For 110 volts A.C.

**RADIO TRADING COMPANY, 97 Hudson Street, N.Y.C.**

OR REAL THRILLS - BE SURE TO SEE

# THE WONDER SHOW OF THE YEAR!

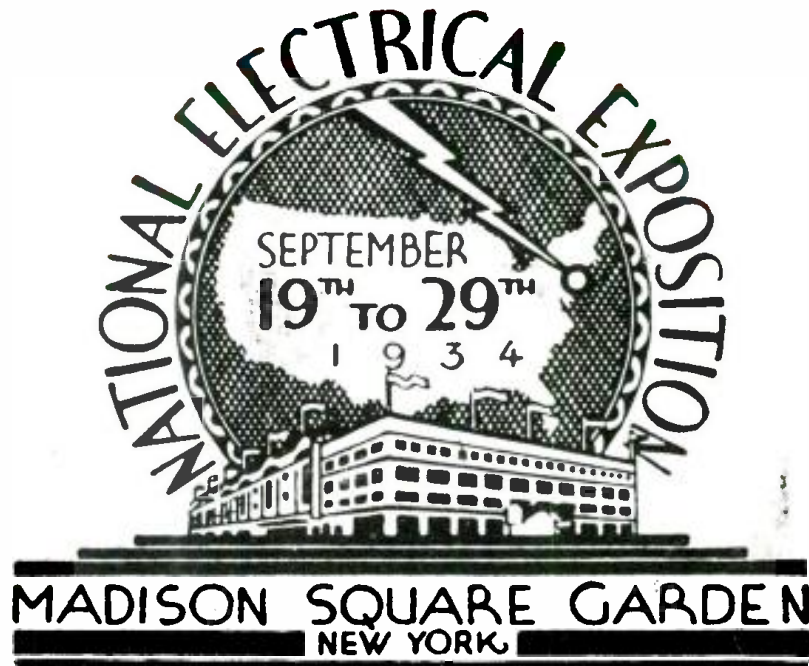

You owe it to yourself to see the year's biggest thrill treat—1934's great

## **RADIO AND ELECTRICAL EXPOSITION**

In a few short, amazing hours, you'll SEE the latest scientific wonders—have them demonstrated before your eyes—improvements and inventions that will be talked about for months to come. Photography by radio . . . . the Latest in Short Wave Radio Receivers . . . . Electric Eye (Photo Electric Cell) . . . . Crystal Broadcasting Studios where you will see Famous Radio and "Talkie" Stars in Action . . . . Army and

Navy Radio Research . . . . New York Police Department — Radio Catches the Crook . . . . The Last Word in Electrical Kitchens . . . . Auditions for Coming Radio Stars . . . . Electro Chemical Exhibits . . . . New Electronic Devices.

These and hundreds of other fascinating exhibits show the incredible progress of the Electrical Age.

**Come! See! Hear!** In no other way can you become so well posted on the latest developments in the radio and electrical fields. Be sure to bring the family too—the 1934 Exposition is a treat for all!

Exposition open every day from 11:00 to 11:00

Admission only 25 cents; after 6 P.M., 35 cents

## **MADISON SQUARE GARDEN**

*Sponsored by the Electrical Association of New York*

**EIGHTH AVENUE AND FIFTIETH STREET**

**NEW YORK CITY**

# MOVIE STARS *Enthuse* OVER THE *New* 1935 MIDWEST-16



**World-Wide Entertainment**  
*Hollywood, Calif.*—Until I received my new Midwest radio, I had never thought it possible to bring in entertainment from half way around the world so clearly.  
*Joan Kewler*  
 (Metro-Goldwyn-Mayer Star)



**Amazing All-Wave Performance**  
*Hollywood, Calif.*—My Midwest is the best set I have ever used. It gives me super foreign reception and new radio adventure. Its performance on all five wave bands amazes me.  
**RICHARD ARLEN**  
 (Paramount Featured Player)



**Thrilling Foreign Reception**  
*Hollywood, Calif.*—Not until I tried out my Midwest 16 did I really appreciate what radio reception was. It thrills me to bring in distant foreign stations as clearly as local programs.  
 (Paramount Star) *Claudette Colbert*



**Better Foreign Reception**  
*Hollywood, Calif.*—I am quite enthused with my Midwest. Many friends who have heard it are delighted with its performance. It brings in, without a doubt, the finest all-wave reception I have ever heard.  
*Neil Hamilton*

*Thrill to Unequaled World-Wide Performance with this—*

## Amazing NEW 1935 SUPER Deluxe 16-Tube ALL-WAVE Radio

9 TO 2,400 METERS (12,000 MILE TUNING RANGE)

30 DAYS FREE TRIAL



**Guaranteed WORLD-WIDE RECEPTION!**

**BEFORE** you buy any radio, write for FREE copy of the new 1935 Midwest "Fifteenth Anniversary" catalog. See for yourself the many reasons why over 110,000 satisfied customers have bought their radios direct from Midwest Laboratories . . . and saved from 1/3 to 1/2. Learn why Midwest radios out-perform sets costing up to \$200 and more. You, too, can make a positive saving of from 30% to 50% by buying this more economical way. Why be content with ordinary so-called "All-Wave", "Dual Wave", "Skip Wave" or "Tri-Wave" receivers when Midwest gives you more wave lengths in today's most perfectly developed 16-tube Super deluxe ALL-WAVE radio that are proven by four years of success . . . that carry an iron-clad guarantee of foreign reception! These bigger, better, more powerful, clearer-toned, super selective radios have FIVE distinct wave bands; ultra short, short, medium, broadcast, and long. Their greater all-wave tuning of 9 to 2400 meters (33 megacycles to 125 KC) enables you to tune in stations 12,000 miles away with clear loud speaker reception. Write TODAY for new FREE catalog!

Now, you can enjoy super American, Canadian, police, amateur, commercial, airplane and ship broadcasts . . . and derive new delight and new excitement from unequalled world-wide performance. Now, you can enjoy the DX-ing hobby and secure verifications from more of

the world's most distant stations. Thrill to the chimes of Big Ben from GSI, London, England . . . tune in on the "Marseillaise" from FYA, Pointoise, France . . . hear sparkling music from EAQ, Madrid, Spain . . . delight in lively tangos from YVIBC, Caracas, Venezuela . . . listen to the call of the Kookaburra bird, from VK2ME, Sydney, Australia, etc. Send today for money-saving facts.

TERMS AS LOW AS \$50 DOWN!

**WORLD'S GREATEST RADIO VALUE**  
**\$57.50** with New **Deluxe Auditorium-Type SPEAKER**  
 . . . LESS TUBES . . .

Jean Harlow, Richard Arlen, Claudette Colbert, Neil Hamilton, Maureen O'Sullivan, Gloria Stuart and Ginger Rogers are some of the movie stars who prefer the Midwest radio because it gives them the super all-wave reception that they desire.

Try the Midwest for thirty days before you decide. Midwest gives you triple protection with: A one-year guarantee, foreign reception guarantee, money-back guarantee.

### 50 ADVANCED 1935 FEATURES

Here are a few of Midwest's superior features: Controllable Expansion of Volume-Selectivity-Sensitivity (Micro-Tenuator) . . . Fidel-A-Trol . . . Triple Calibration Plus . . . Pure Silver Wire . . . Ceramic Coil Forms . . . Separate Audio Generator . . . Simplified Tuning Guide Lights . . . Compact Synchronized Band Switch . . . Amplified Automatic Volume Control . . . 7 KC Selectivity . . . Power Driver Stage . . . 16 Latest Type Tubes . . . etc. Read about these and 38 other features in the new FREE Midwest catalog. Never before so much radio for so little money. Write for FREE catalog.

### DEAL DIRECT WITH LABORATORIES

Increasing costs are sure to result in higher radio prices soon. Buy before the big advance . . . NOW! . . . while you can take advantage of Midwest's sensational values . . . No middlemen's profits to pay. You can order your radio from the new Midwest catalog with as much certainty of satisfaction as if you were to select it in our great radio laboratories. You save 30% to 50% when you buy direct this popular way . . . you get 30 days FREE trial . . . as little as \$5.00 down puts a Midwest radio in your home. Satisfaction guaranteed or money back. Write for FREE catalog.

Sign and mail coupon . . . or, send name and address on postal card . . . NOW!

**SAVE UP TO 50%**



**NEW STYLE CONSOLES**  
 The new, big, Midwest 30-page 1935 catalog pictures a complete line of beautiful, artistic de luxe consoles and chassis . . . in four colors . . . a model for every purse. Hand made by master craftsmen, they harmonize beautifully with any furniture arrangement. Write for new FREE catalog today!

**MAIL COUPON TODAY! FOR AMAZING 30-DAY FREE TRIAL OFFER AND NEW 1935 CATALOG**

MIDWEST RADIO CORP., Dept. 618 Cincinnati, Ohio.

Without obligation on my part send me your new FREE 1935 catalog, and complete details of your liberal 30-day FREE trial offer. This is NOT an order.

Name \_\_\_\_\_  
 Address \_\_\_\_\_  
 Town \_\_\_\_\_ State \_\_\_\_\_

User-Agents Make Easy Extra Money  
 Check Here for Details

**MIDWEST RADIO CORP.**  
 DEPT. 618 — CINCINNATI, OHIO, U. S. A.  
 Established 1920 Cable Address Miraco. . . All Codes